

JT921

Parts Manual

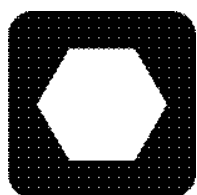

Ditch Witch[®]

JT921

ISSUE NO. 09PL-08/11

For Replacement Copy Order **P/N 053-151**

This product is covered by one or more of the following patents:

US 4,953,638; 5,148,880; 5,242,026; 5,341,887; 5,490,569; 5,684,466; 5,713,423, 5,740,703; 5,758,553; 5,794,719; 5,880,680; 5,941,322; 6,085,852C1; 6,109,371; 6,179,065; 6,216,803; 6,250,403; 6,250,404; 6,290,606; 6,311,790; 6,411,094; 6,543,551; 6,550,547; 6,672,409; 6,739,413; 6,761,231; 6,776,246; 6,808,210; 6,827,158; 6,848,506; 6,871,712; 6,896,077; 7,000,710; 7,011,166; 7,013,990; 7,018,164; 7,025,152; 7,038,454; 7,111,693; 7,150,331; RE37,450; RE37,923; RE37,975; RE38,418

AU 689,533; 706,544; 718,034, 755,862

CA 2,156,398; 2,217,899

FR 674,093

DE 694 17 019; 695 29 634; 697 28 716;

EP 0927892; 1466068

GB 2,312,006; 2,418,553; EP674,093; EP817,901; EP846,841; EP927,892

JP 3,458,247

Other U.S. and foreign patents pending

This manual contains information concerning the following models:
JT921 Directional Drilling System

Copyright 2005, 2006, 2007, 2008, 2011 by The Charles Machine Works, Inc.



**Ditch
Witch**

, Ditch Witch, CMW, AutoCrowd, Jet Trac, Roto Witch, Subsite, Fluid Miser, Power Pipe, Super Witch, Pierce Arrow, Zahn, The Underground, and The Underground Authority Worldwide are registered trademarks of The Charles Machine Works, Inc.

ID0135193

FOREWORD

This manual contains illustrated parts lists to help you select quality ProTech[®] Replacement parts for your Ditch Witch[®] equipment. Using other replacement parts will lessen the productivity of your equipment.

- ◆ Part numbers enclosed in a box are no longer available from The Charles Machine Works, Inc. Your local Ditch Witch dealer may be able to locate the part for you.
- ◆ Footnotes provide more information to help you identify parts shown in the manual.
- ◆ Assembly instructions and Tech Bits articles referenced in footnotes are available through your local Ditch Witch dealer.
- ◆ Description and specifications in this book were current at publication. However, The Charles Machine Works, Inc. reserves the right to improve equipment, so this manual might not reflect the most current improvements.
- ◆ Instructions on recommended equipment use and maintenance are in the Operator's Manual that was shipped with your equipment.

Keep the following in mind when ordering ProTech replacement parts:

- ◆ Specify parts you need by part number and description, not by illustration reference numbers.
- ◆ Have equipment model and serial number on hand to help ensure you get the right parts for your machine whether it's old or new.

Thank you for buying and using Ditch Witch equipment and ProTech replacement parts.

WARRANTY

DW WARRANTY Policy
July, 2005

POLICY 1: DITCH WITCH® EQUIPMENT AND REPLACEMENT PARTS LIMITED WARRANTY POLICY

Subject to the limitation and exclusions herein, free replacement parts will be provided at any authorized Ditch Witch dealership for any Ditch Witch equipment or parts manufactured by The Charles Machine Works, Inc. (CMW) that fail due to a defect in material or workmanship within one (1) year of first commercial use (Exception: 2 years for all SK500 Attachments). Free labor will be provided at any authorized Ditch Witch dealership for installation of parts under this warranty during the first year following "initial commercial" use of the serial numbered Ditch Witch equipment on which it is installed. The customer is responsible for transporting their equipment to an authorized Ditch Witch dealership for all warranty work.

EXCLUSIONS FROM PRODUCT WARRANTY

- All incidental or consequential damages.
- All defects, damages, or injuries caused by misuse, abuse, improper installation, alteration, neglect, or uses other than those for which products were intended.
- All defects, damages, or injuries caused by improper training, operation, or servicing of products in a manner inconsistent with manufacturer's recommendations.
- All engines and engine accessories (these are covered by original manufacturer's warranty).
- Tires, belts, and other parts which are subject to another manufacturer's warranty. (Such warranty will be available to purchaser.)
- ALL IMPLIED WARRANTIES NOT EXPRESSLY STATED HEREIN, INCLUDING ANY WARRANTY OF FITNESS FOR A PARTICULAR PURPOSE AND MERCHANTABILITY.

IF THE PRODUCTS ARE PURCHASED FOR COMMERCIAL PURPOSES, AS DEFINED BY THE UNIFORM COMMERCIAL CODE, THEN THERE ARE NO WARRANTIES WHICH EXTEND BEYOND THE FACE HEREOF AND THERE ARE NO IMPLIED WARRANTIES OF ANY KIND WHICH EXTEND TO A COMMERCIAL BUYER. ALL OTHER PROVISIONS OF THIS LIMITED WARRANTY APPLY INCLUDING THE DUTIES IMPOSED.

Ditch Witch products have been tested to deliver acceptable performance in most conditions. This does not imply they will deliver acceptable performance in all conditions. Therefore, to assure suitability, products should be operated under anticipated working conditions prior to purchase.

Defects will be determined by an inspection within thirty (30) days of the date of failure of the product or part by CMW or its authorized dealer. CMW will provide the location of its inspection facilities or it's nearest authorized dealer upon inquiry. CMW reserves the right to supply remanufactured replacement parts under this warranty as it deems appropriate.

Extended warranties are available upon request from your local Ditch Witch dealer or CMW.

Some states do not allow exclusion or limitation of incidental or consequential damages, so the above limitation or exclusion may not apply. Further, some states do not allow exclusion of or limitation of how long an implied warranty lasts, so the above limitation may not apply. This limited warranty gives product owner specific legal rights and the product owner may also have other rights which vary from state to state.

For information regarding this limited warranty, contact CMW's Product Support Department, P.O. Box 66, Perry, OK 73077-0066, or contact your local Ditch Witch dealer.

CONTENTS

Decals

Decal Location - JT921/JT921S	8
-------------------------------------	---

Engine Components

Air Filter System - Caterpillar Diesel	22
Engine - Caterpillar Diesel	14
Engine Installation - Caterpillar Diesel	16
Engine Service - Caterpillar Diesel	18
Fuel Filter System - Caterpillar Diesel	24
Radiator - Caterpillar Diesel	20
Throttle - Caterpillar Diesel	26

Frame Components

Carriage	36
Covers - Caterpillar Diesel	46
Cylinder Grease	54
Drill Frame Components	30
Fuel Reservoir	44
Gear Box - Rotation Drive	40
Idler	50
Stabilizer - Rear	48
Tension Spring	52
Track Group - Rubber	42
Wrench - Front	34

Operator's Station

Console Gauges	62
Operators Station Gauges	60
Seat Mount	58

Hydraulics

Anchor Drive Hydraulics	126
Anchor Hydraulics	122
Auxiliary Backup Wrench Hydraulic	116
Breakout Hydraulics	114
Carriage Rotation Hydraulics	102
Carriage Thrust Hydraulics	108
Control Valve & Levers	100
Control Valve/Levers - 3-Spool	96
Drive Control Supply Hydraulics	78
Drive Control Valve & Levers	82
Frame Tilt Hydraulics	84
Ground Drive Hydraulics	80
Hydraulic Control Valve - 2-Spool	94
Hydraulic Control Valve - 2-Spool	98
Hydraulic Cylinder (2.0"X1.0")	130
Hydraulic Cylinder (3.0"X1.5")	132
Hydraulic Diagram	70
Hydraulic Diagram - Auto-bore	68
Hydraulic Motor - Tapered Keyed Shaft 1-1/4"	128
Hydraulic Reservoir	72
Hydraulic Schematic - w/Auto-bore shutoff	66
Main Supply Hydraulics	92
Mud Motor Hydraulics	118
Oil Cooler Hydraulics	74
Oil Cooler Hydraulics - Caterpillar Diesel	76
Rotation Hydraulics - Auto-bore	106

Rotation Hydraulics	104
Stabilizer	88
Stabilizer Hydraulics	86
Thrust Hydraulics - Auto-bore	112
Thrust Hydraulics	110
Track Extended Hydraulics	90

Electrical

Electrical Diagram	150
Electrical Diagram - Console	158
Electrical Diagram - Engine Frame	152
Electrical Diagram - Gauge Buss	162
Electrical Diagram - Gauge, Auto-bore	148
Electrical Schematic - Auto-bore	136
Electrical Schematic - JT920 T2	142
Electrical Strike System	156

Lubricator Systems

Thread Lubricator - Begins	168
----------------------------------	-----

Anchor Systems

Anchor Counterbalance Weight	174
Anchor System	172
Anchoring Parts	176
Hydraulic Stake Driver	178

Fluid Systems

Fluid Pump Plumbing	194
Mud Pump	184
Mud Pump - 9 GPM	186
Mud Pump Plumbing w/o Tank	190
Mud Pump Plumbing	188
Mud Tank Plumbing	192
Tank Support	182

Pipe Loader Systems

Drill Pipe Accessories	198
------------------------------	-----

Accessories

Drilling Fluid Transfer	212
Garden Hose Adapter	210
Grounding Cables	204
Mud Mixing Accessories	202
Wash Wand	208
Water Transfer System	206

Miscellaneous

Bolt/Nut Torque Chart	216
Filters	220
Optional Kits	221
Parts Manual Change Request	223
Related Publications	220
Replacement O-Ring Chart	219
Warranty Registration	226

DECALS

DECAL LOCATION JT921S / JT921

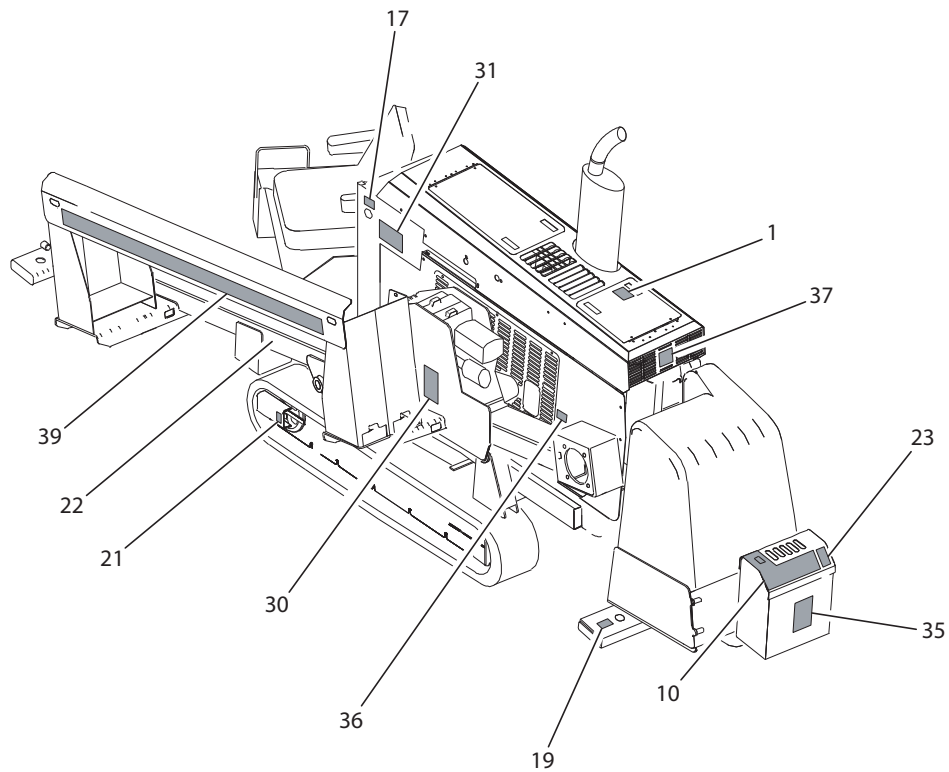
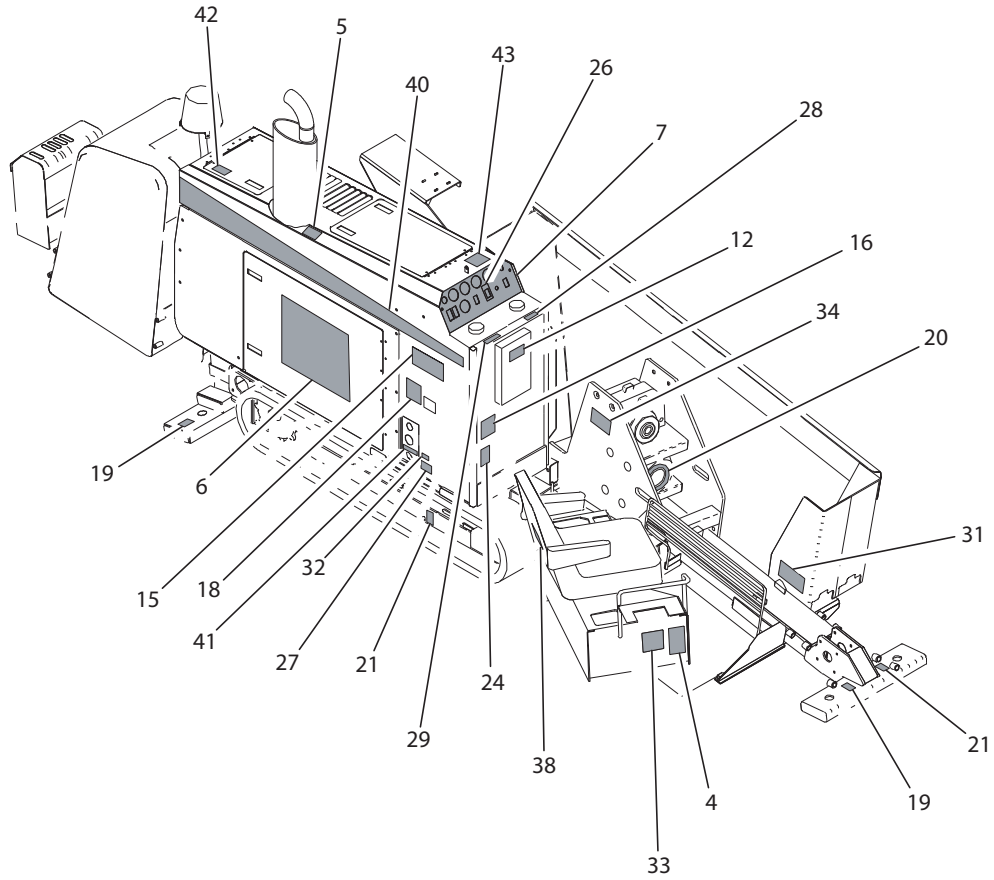

DECAL LOCATION JT921S / JT921

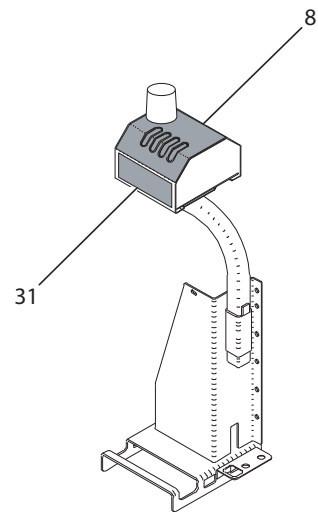
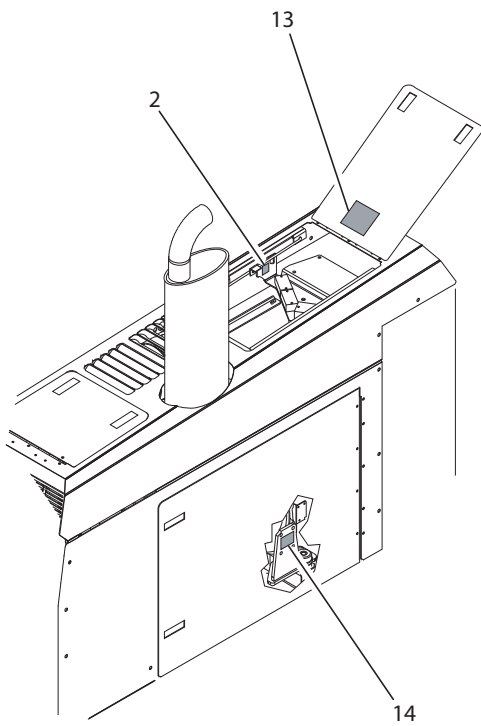
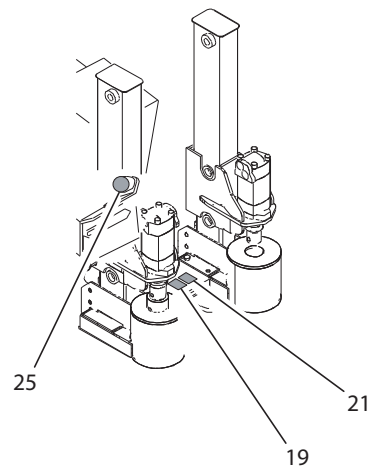
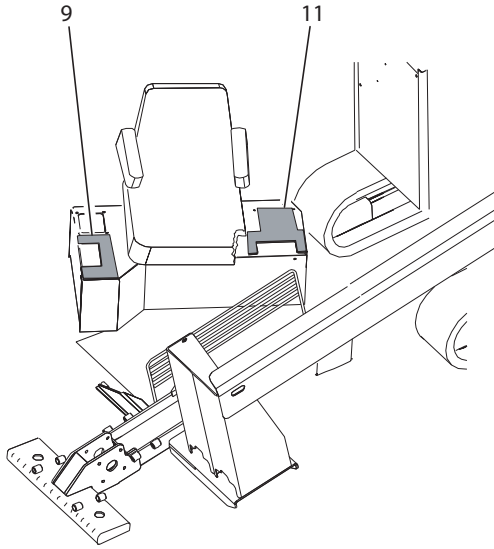

DECAL LOCATION JT921S / JT921

REF NO.	PART NUMBER	QTY	DESCRIPTION	REMARKS
	275-979		DECAL KIT - JT921S	
	275-978		DECAL KIT - JT921	OBSOLETE
1	273-138	1	NOTICE COOLANT	
2	273-198	1	TRACKER CONTROL	SEE FOOTNOTE 1
3	273-267	1	DITCH WITCH BATTERY	SEE FOOTNOTE 2
4	273-278	1	DANGER WRENCH	
5	273-423	1	CAUTION HOT PARTS	
6	273-434	1	DITCH WITCH	
7	273-557	1	INSTRUMENT PANEL	
8	273-558	1	ANCHOR DRIVER CONTROL PANEL	
9	273-559	1	RIGHT CONSOLE PANEL	
10	273-560	1	SET UP CONTROL PANEL	
11	273-561	1	LEFT CONSOLE PANEL	
12	273-562	1	NOTICE READ MANUAL	
13	273-563	1	ELECTRICAL CENTER	
14	273-564	1	PRIMARY POWER/GLOW PLUG	
15	274-049	1	DANGER ELECTROCUTION	
16	274-050	1	WARNING JOBSITE HAZARD	
17	274-198	1	NOTICE OIL LEVEL	
18	274-291	1	SOUND POWER 10	SEE FOOTNOTE 1
19	274-318	3	TIE DOWN LOCATION	
20	274-415	1	ROTATION MARKER	
21	274-442	3	LIFT LOCATION	
22	274-711	1	HYD OIL DRAIN	
23	274-724	1	ONE CALL NOTIFICATION	
24	274-780	1	JET TRAC PATENT(S)	
25	274-881	1	FLUID PRESSURE SCALE 1500 PSI	
26	274-947	1	AUTO BORE OVERRIDE PANEL	APPLY DECAL OVER THROTTLE
27	275-033	1	NOTICE ELECTRICAL SYSTEM	
28	275-120	1	RESERVOIR (THF)	
29	275-148	1	FUEL TANK (DIESEL)	
30	275-184	1	WARNING MOVING PARTS	
31	275-197	3	DANGER ROTATING SHAFT	
32	275-203	1	BATTERY	
33	275-306	1	DITCH WITCH EMBLEM	
34	275-341	1	WARNING SLIDING PARTS	
35	275-383	1	NOTICE SLOPE PARKING	
36	275-400	1	NOTICE OIL LEVEL	
37	275-449	1	DITCH WITCH LOGO PLACARD	
38	275-450	1	LOGO PLACARD	
39	273-614	1	JT921S MODEL ID / PIPEBOX	SEE FOOTNOTE 3
	273-612	1	JT921 MODEL ID / PIPEBOX	OBSOLETE
40	273-613	1	JT921S MODEL ID W/ STRIPE	SEE FOOTNOTE 3
	273-611	1	JT921 MODEL ID W/ STRIPE	OBSOLETE
41	700-212	1	MASTER DISCONNECT SWITCH	
42	273-459	1	NOTICE EXPLOSION POSSIBLE	
43	273-053	1	STARTING PROCEDURE	

FOOTNOTES

1. NOT PART OF KIT.
2. LOCATE DECAL ON BATTERY SO THAT DECAL IS VISIBLE WHEN VIEWING BATTERY.
3. PART OF KIT NUMBER 275-979.

ENGINE COMPONENTS

ENGINE SERVICE (CATERPILLAR / PERKINS DIESEL)

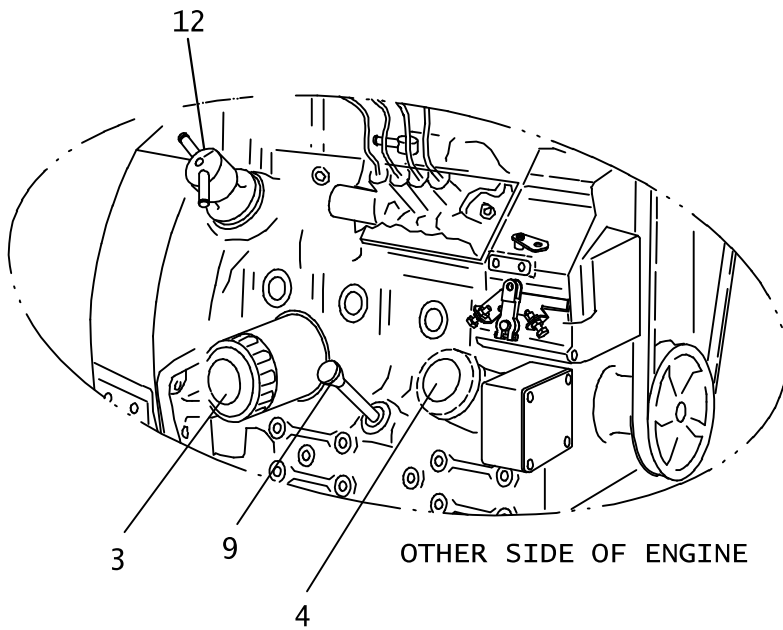
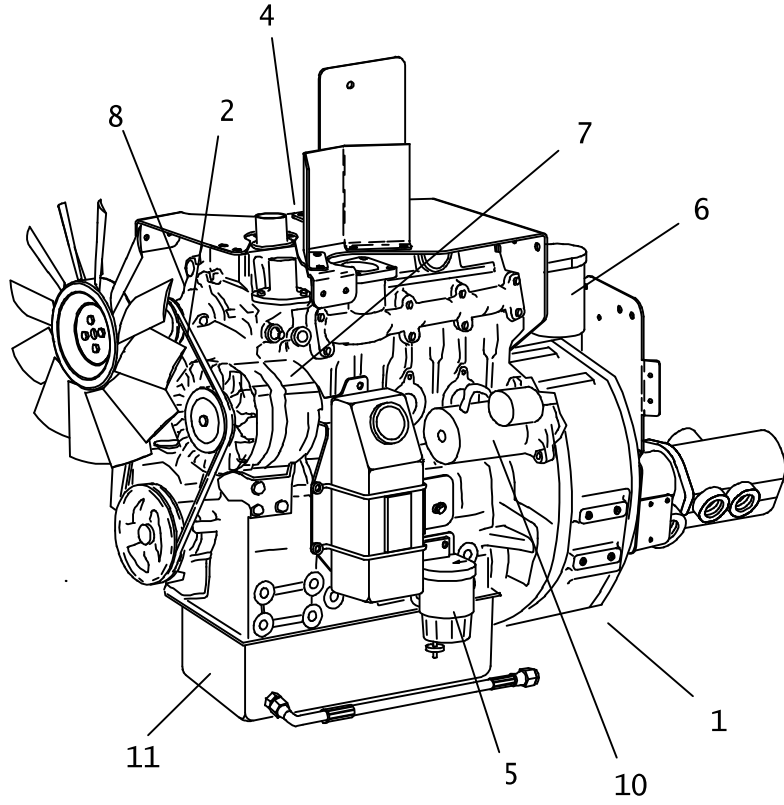

ENGINE SERVICE (CATERPILLAR / PERKINS DIESEL)

REF NO.	PART NUMBER	QTY	DESCRIPTION	REMARKS
1.	194-453	1	ENGINE (CATERPILLAR DIESEL T2)	OBSOLETE
	194-670	1	ENGINE (PERKINS 404C-22 DIESEL T2)	ENGINE OPTION
2.	170-474	1	FAN BELT	
3.	153-113	1	OIL FILTER ELEMENT	
4.	194-582	2	OIL FILLER CAP	SEE NOT SHOWN LIST - USE WITH OIL FILLER CAP SEAL (118-466)
5.	194-488	1	FUEL FILTER / WATER SEPERATOR	
	194-491	-	FUEL FILTER ELEMENT (30 MICRON)	
6.	194-550	1	FUEL FILTER (FINAL)	
	194-551	-	FUEL FILTER ELEMENT (2 MICRON)	OBSOLETE
	194-075	-	FUEL FILTER ELEMENT KIT (2 MICRON)	
7.	215-223	1	ALTERNATOR	
	213-403	1	ALTERNATOR (DENSO)	
8.	194-177	1	WATER PUMP	SEE NOT SHOWN LIST - USE WITH WATER PUMP GASKET (194-504)
9.	194-581	1	ENGINE OIL DIP STICK	
10.	194-178	1	STARTER	
11.	194-583	1	OIL RESERVOIR	SEE NOT SHOWN LIST - USE WITH OIL RESERVOIR GASKET (153-139)
12.	194-887	1	FUEL TRANSFER PUMP	SEE NOT SHOWN LIST - USE WITH FUEL TRANSFER PUMP SEAL (194-888)

NOT SHOWN:

194-888	1	FUEL TRANSFER PUMP SEAL
194-504	1	WATER PUMP GASKET
215-246	1	THERMOSTAT
153-135	1	THERMOSTAT GASKET
153-139	1	OIL RESERVOIR GASKET
215-1080	1	OIL PRESSURE SWITCH
194-889	1	INTAKE MANIFOLD GASKET
153-136	1	EXHAUST MANIFOLD GASKET
053-144	1	CAT 3024C PARTS MANUAL
054-128	1	CAT 3013C / 3024C OPER / MAINT MANUAL
055-076	1	CAT 3013C / 3024C SERVICE MANUAL
056-005	1	CAT 3013C / 3024C USER HANDBOOK

FOOTNOTES:

NOTE:

ENGINE INSTALLATION (CATERPILLAR / PERKINS DIESEL)

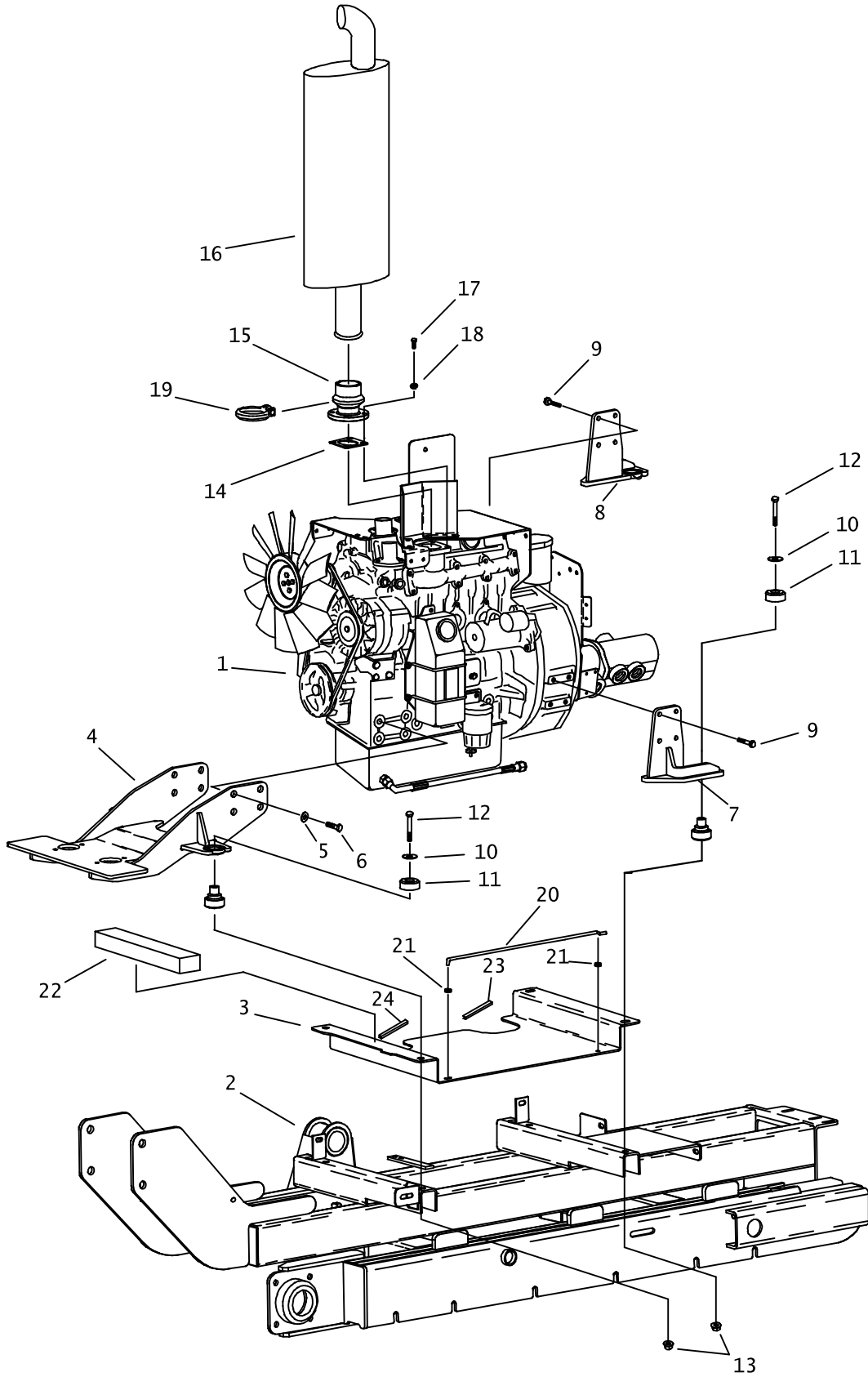

ENGINE INSTALLATION (CATERPILLAR / PERKINS DIESEL)

REF NO.	PART NUMBER	QTY	DESCRIPTION	REMARKS
1.	194-453	-	ENGINE (CATERPILLAR DIESEL T2)	OBSOLETE
	194-670	-	ENGINE - PERKINS 404C-22 DIESEL T2	ENGINE OPTION
2.	350-501	-	TRACK FRAME WELDMENT	
3.	320-608	1	BOTTOM PLATE	
4.	320-496	1	FORWARD ENGINE MOUNT	
5.	105-071	12	WASHER (1/2")	
6.	107-494	8	SCREW (M14-1.50 X 30MM)	
7.	320-498	1	RIGHT REAR ENGINE MOUNT	
8.	320-497	1	LEFT REAR ENGINE MOUNT	
9.	105-826	8	FLG LK BOLT (3/8"-NC X 1")	USE LOCTITE 242 OR EQUIVALENT
10.	105-088	4	WASHER (9/16")	
11.	116-496	4	SHOCK MOUNT	
12.	106-336	4	SCREW (M12-1.75 X 90MM)	
13.	106-709	4	FLG LK NUT (M12-1.75)	USE LOCTITE 242 OR EQUIVALENT
14.	157-417	-	MUFFLER GASKET	
15.	194-483	1	MANIFOLD ADAPTER	
16.	196-362	1	MUFFLER	
17.	105-806	4	SCREW (M8-1.25 X 25MM)	TORQUE TO 20 FT-LBS
18.	105-091	4	LOCK WASHER (5/16")	
19.	196-195	1	LOWER CLAMP (HEADER PIPE)	
20.	179-875	1	PROP ROD	
21.	118-211	2	GROMMET (1/4")	
22.	118-151	1	SOUND INSULATION	
23.	115-686	AR	BULK EDGE (5/32", SOLD PER 1")	USE 10"
24.	118-151	AR	BULK EDGE (5/32", SOLD PER 1")	USE 8.5"

NOT SHOWN:

FOOTNOTES:

NOTE:

ENGINE (CATERPILLAR / PERKINS DIESEL) JT921

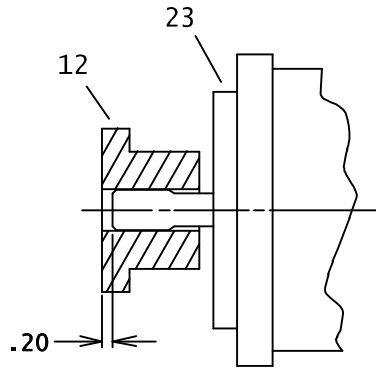

DISTANCE FROM END OF PUMP SHAFT
TO FACE OF SPLINE HUB

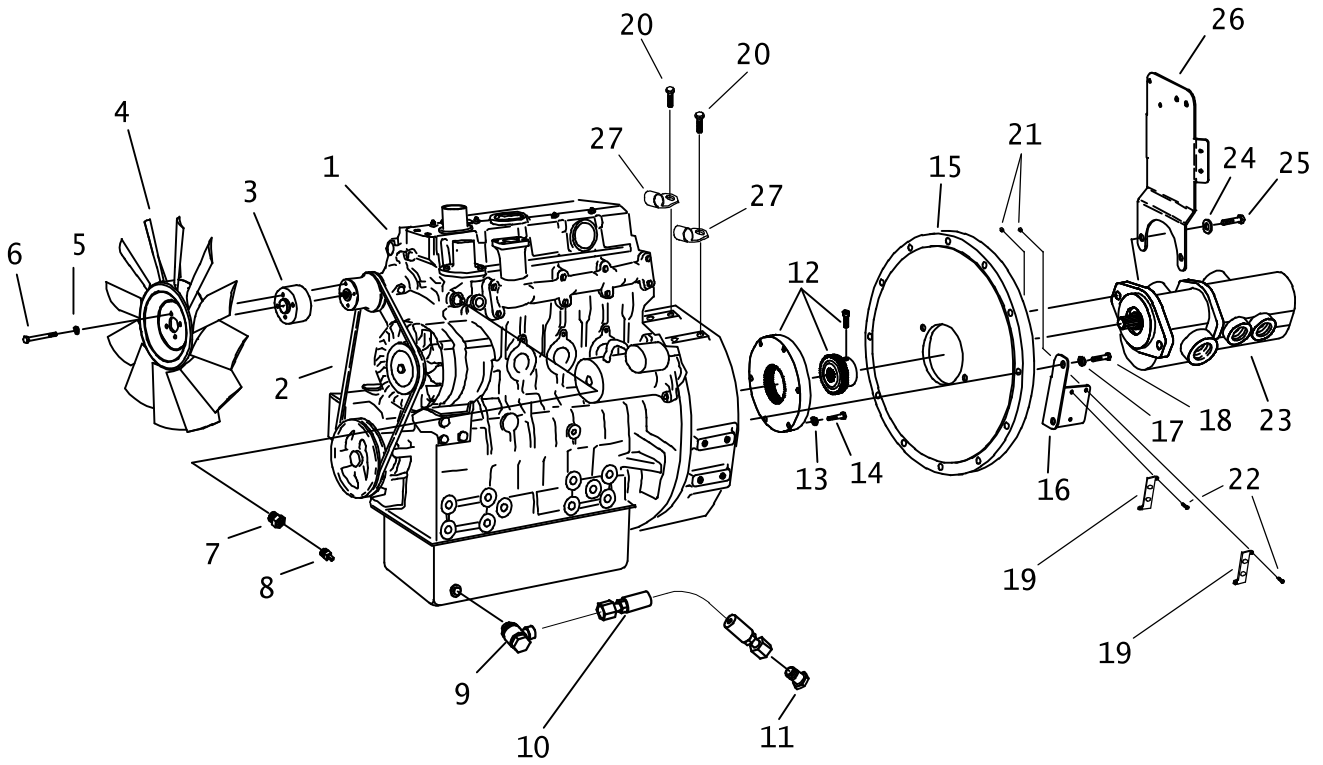

ENGINE (CATERPILLAR / PERKINS DIESEL) JT921

REF NO.	PART NUMBER	QTY	DESCRIPTION	REMARKS
1.	194-453	-	ENGINE (CATERPILLAR DIESEL T2)	OBSOLETE
	194-670	-	ENGINE - PERKINS 404C-22 DIESEL T2	ENGINE OPTION
2.	170-400	1	FAN BELT	
3.	179-693	1	FAN SPACER	
4.	194-519	1	FAN (16" PULLER)	
5.	105-079	4	LOCK WASHER (1/4")	
6.	107-025	4	SCREW (M6-1.00 X 50MM)	TORQUE TO 8 FT-LBS. USE LOCTITE 242 OR EQUIVALENT
7.	115-251	1	REDUCER (06N-02NF)	
8.	217-565	1	TEMPERATURE SENDER (100 - 280F)	
9.	150-1385	1	BANJO FITTING (M16)	BEGINS WITH S/N:
10.	515-265	1	HOSE (060FX-14"-3000)	BEGINS WITH S/N:
11.	154-330	1	PLUG (060)	BEGINS WITH S/N:
12.	194-544	1	FLYWHEEL / PUMP COUPLER	
	194-545	-	NYLON FLANGE	
	194-546	-	13 TOOTH SPLINE HUB	
	105-757	-	BOLT (3/8"-NC X 1.25)	TORQUE TO 50 FT-LBS
13.	105-091	8	LOCK WASHER (5/16")	
14.	105-094	8	BOLT (5/16"-NC X 1")	TORQUE TO 25 FT-LBS. USE LOCTITE 271 OR EQUIVALENT
15.	324-791	1	MOUNT PLATE	
16.	320-617	1	FUSE BRACKET	
17.	105-072	12	LOCK WASHER (3/8")	
18.	105-286	12	BOLT (3/8"-NC X 1-3/4")	TORQUE TO 40 FT-LBS
19.	211-306	2	FB/HVAMI FUSE HOLDER	SUPERSEDED BY 363-714
20.	106-380	2	FLG LK SCREW (M8-1.25 X 16MM)	
21.	105-215	4	NUT (#6-32)	
22.	106-367	4	SCREW (#6-32 X 1/2" PLPS SS)	
23.	158-420	1	HYDRAULIC PUMP	
	500-461	-	SEAL REPAIR KIT	
24.	105-071	2	WASHER (1/2")	
25.	105-048	2	BOLT (1/2"-NC X 1-1/2")	USE LOCTITE 242 OR EQUIVALENT
26.	344-726	1	SUPPORT PLATE	
27.	110-333	2	BOLT-ON CLAMP (1")	

NOT SHOWN:

FOOTNOTES:

NOTE:

RADIATOR (CATERPILLAR / PERKINS DIESEL)

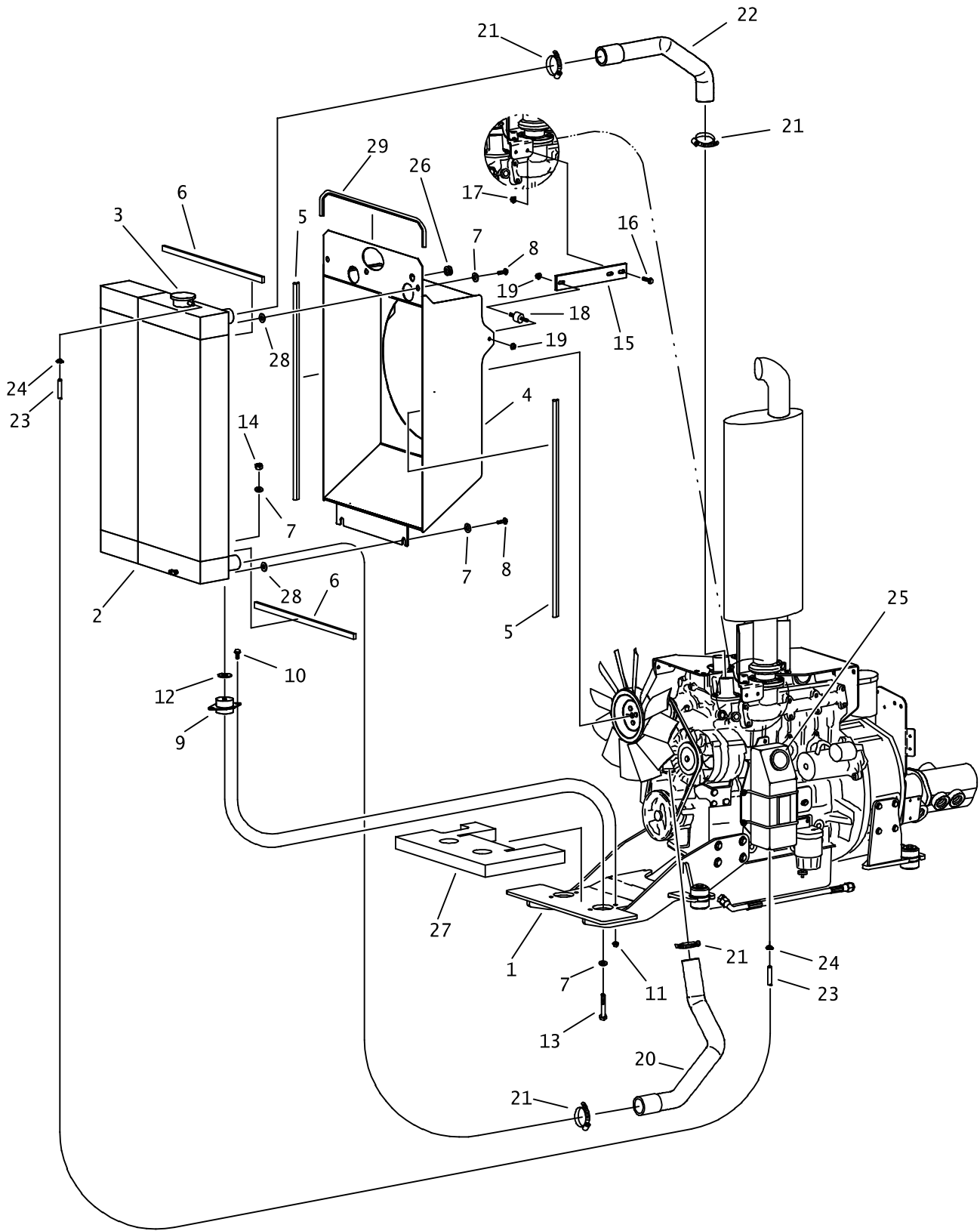

RADIATOR (CATERPILLAR / PERKINS DIESEL)

REF NO.	PART NUMBER	QTY	DESCRIPTION	REMARKS
1.	320-496	-	FORWARD ENGINE MOUNT	
2.	194-463	1	RADIATOR/HOC	
3.	111-084	-	RADIATOR CAP	
4.	362-975	1	SHROUD	
5.	117-948	AR	BULK EDGE (3/32", SOLD PER FT)	USE 2 @ 23.7"
6.	115-380	AR	WEATHER STRIP (3/8" X 3/4")	USE 2 @ 17"
7.	106-396	9	WASHER (M10, HARDENED)	
8.	106-654	5	FLG LK SCREW (M10-1.50 X 16MM)	
9.	116-539	2	ISOLATOR	
10.	106-162	4	FLG SCREW (M8-1.25 X 20MM, GD8)	
11.	106-386	4	FLG LOCKNUT (M8-1.25)	
12.	105-071	2	WASHER (1/2")	
13.	106-642	2	SCREW (M10-1.5 X 65MM)	
14.	105-894	2	LOCKNUT (M10-1.50, PRV TRQ 10.9)	
15.	320-607	2	RADIATOR BRACKET	
16.	106-987	4	FLG LK SCREW (M6-1.00 X 16MM)	
17.	106-385	4	FLG LOCKNUT	
18.	116-540	2	SHEAR MOUNT	
19.	105-832	4	FLG LOCKNUT (1/4-NC)	
20.	118-067	1	COOLANT HOSE	
21.	110-133	4	WORM CLAMP (1.062" TO 1.937")	
22.	118-068	1	COOLANT HOSE	
23.	116-108	AR	BULK HOSE (5/16", SOLD PER 1")	USE 1 @ 55"
24.	110-249	2	WORM CLAMP (1/4" TO 5/8")	
25.	364-566	-	COOLANT OVERFLOW RESERVOIR	
26.	118-173	1	GROMMET (9/16")	
27.	118-150	1	SOUND INSULATION	
28.	106-397	5	WASHER (M12, HARDENED)	
29.	116-421	AR	BULK EDGE (1/8", SOLD PER FT)	USE 1 @ 24"

NOT SHOWN:

FOOTNOTES:

NOTE:

AIR FILTER SYSTEM (CATERPILLAR / PERKINS DIESEL)

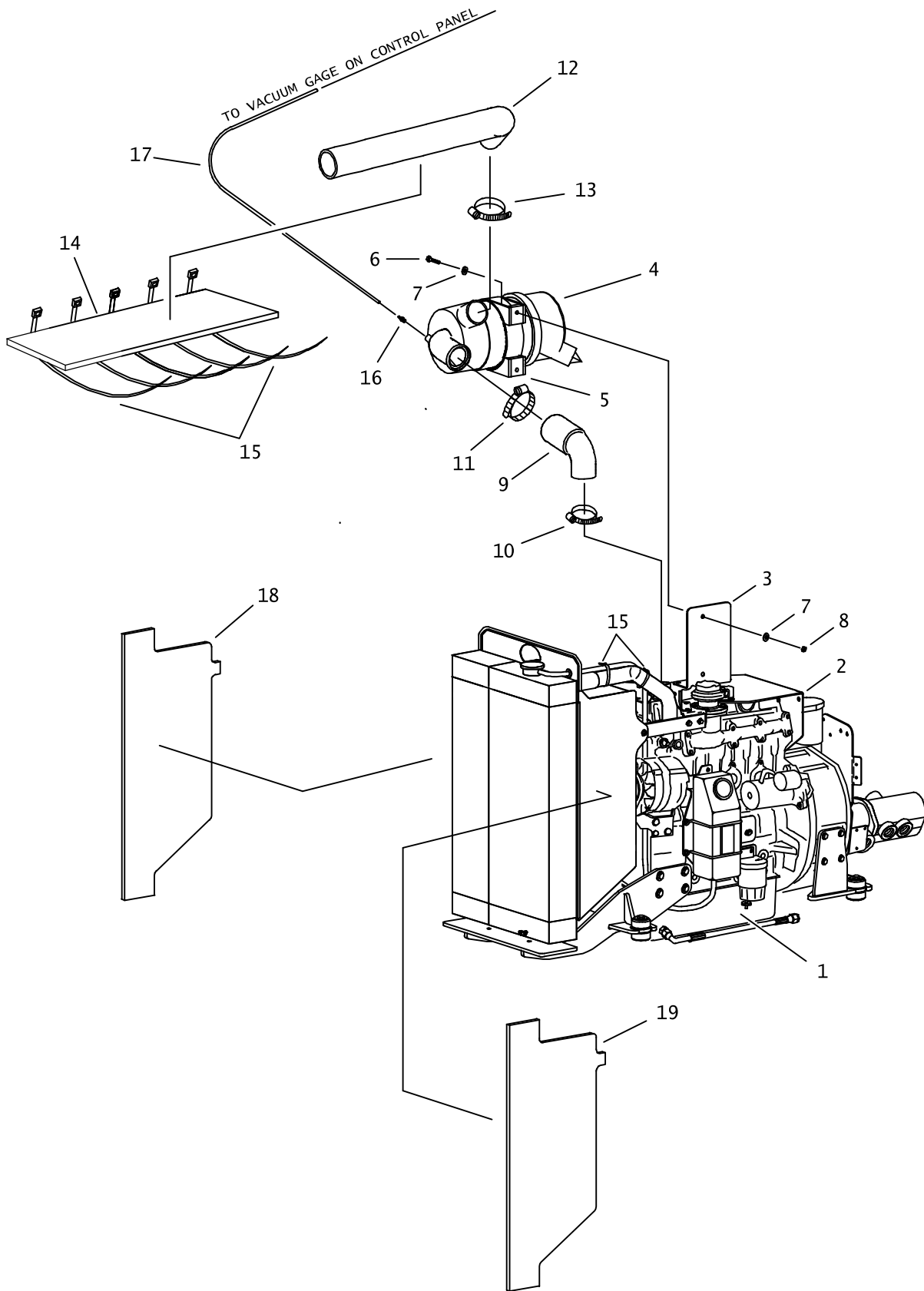

AIR FILTER SYSTEM (CATERPILLAR / PERKINS DIESEL)

REF NO.	PART NUMBER	QTY	DESCRIPTION	REMARKS
1.	194-453	-	ENGINE (CATERPILLAR DIESEL T2)	OBSOLETE
	194-670	-	ENGINE - PERKINS 404C-22 DIESEL T2	ENGINE OPTION
2.	320-618	-	FUEL FILTER BRACKET	
3.	320-621	-	AIR FILTER BRACKET	
4.	194-297	1	AIR FILTER	
	194-758	-	ELEMENT (SAFETY)	
	194-759	-	ELEMENT (PRIMARY)	
	194-760	-	COVER	
5.	149-165	1	MOUNTING CLAMP	
6.	106-328	2	SCREW (M8-1.25 X 40MM)	
7.	106-389	4	WASHER (M8)	
8.	107-096	2	LOCKNUT (M8-1.25,NLK)	
9.	118-070	1	AIR INTAKE HOSE	
10.	110-815	1	T-BOLT CLAMP (2.25" TO 2.56")	
11.	111-135	1	T-BOLT CLAMP (2.750" TO 3.062")	
12.	118-071	1	AIR INTAKE HOSE	
13.	110-169	1	WORM CLAMP (2.812" TO 3.750")	
14.	118-169	1	SOUND INSULATION	
15.	110-031	7	CABLE TIE (1-1/2" TO 7")	
16.	155-150	1	S/O COUPLER (02N-02H)	USE WITH PIPE THREAD SEALANT
17.	116-192	AR	BULK HOSE (7/64", SOLD PER 1")	USE 1 @ 53"
18.	118-148	1	SOUND INSULATION	
19.	118-149	1	SOUND INSULATION	

NOT SHOWN:

FOOTNOTES:

NOTE:

FUEL FILTER SYSTEM (CATERPILLAR/PERKINS DIESEL)

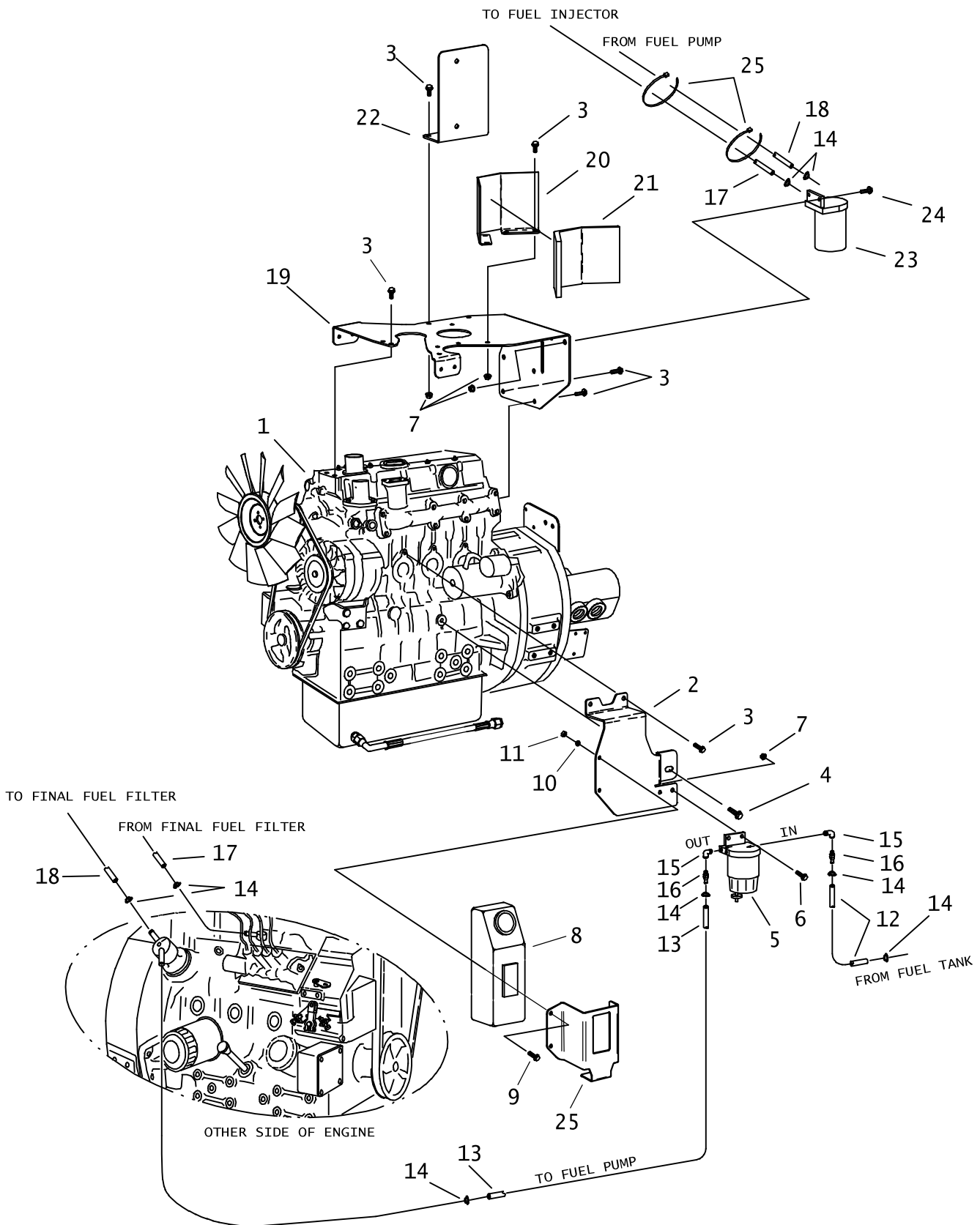

FUEL FILTER SYSTEM (CATERPILLAR/PERKINS DIESEL)

REF NO.	PART NUMBER	QTY	DESCRIPTION	REMARKS
1.	194-453	-	ENGINE (CATERPILLAR DIESEL T2)	OBSOLETE
	194-670	-	ENGINE - PERKINS 404C-22 DIESEL T2	ENGINE OPTION
2.	320-622	1	COOLANT BOTTLE BRACKET	
3.	106-380	15	FLG LK SCREW (M8-1.25 X 16MM)	
4.	107-585	1	FLG LK SCREW (M10-1.50 X 16MM)	
5.	194-488	1	FUEL FILTER / WATER SEPERATOR WO	
	194-491	-	FUEL FILTER ELEMENT (30 MICRON)	
6.	106-162	2	FLG SCREW (M8-1.25)	
7.	106-386	11	FLG LOCKNUT (M8-1.25)	
8.	364-566	1	COOLANT OVERFLOW RESERVOIR	
9.	106-379	2	FLG LK SCREW (M6-1.00 X 20MM)	
10.	106-388	2	WASHER (M6)	
11.	106-237	2	LOCKNUT (M6-1.00, PRV TRQ, NLK)	
12.	116-108	AR	BULK HOSE (5/16", SOLD PER 1")	USE 1 @ 50"
13.	116-108	AR	BULK HOSE (5/16", SOLD PER 1")	USE 1 @ 46"
14.	110-249	8	WORM CLAMP (1/4" TO 5 /8 ")	
15.	155-120	2	STREET ELBOW (04N-04NF90)	
16.	155-162	2	S/O COUPLER (04N-05H)	
17.	116-108	AR	BULK HOSE (5/16", SOLD PER 1")	USE 1 @ 24"
18.	116-108	AR	BULK HOSE (5/16", SOLD PER 1")	USE 1 @ 24"
19.	320-618	1	FUEL FILTER BRACKET	
20.	323-200	1	HEAT SHIELD	
21.	118-147	1	SOUND INSULATION	
22.	320-621	1	AIR FILTER BRACKET	
23.	194-550	-	FUEL FILTER (FINAL)	
	194-551	-	FUEL FILTER ELEMENT (2 MICRON)	OBSOLETE
	194-075	-	FUEL FILTER ELEMENT KIT (2 MICRON)	
24.	106-992	2	FLG LK SCREW (M8-1.25 X 25MM)	
25.	325-644	1	COOLANT BOTTLE BRACKET	

NOT SHOWN:

FOOTNOTES:

NOTE:

THROTTLE (CATERPILLAR / PERKINS DIESEL)

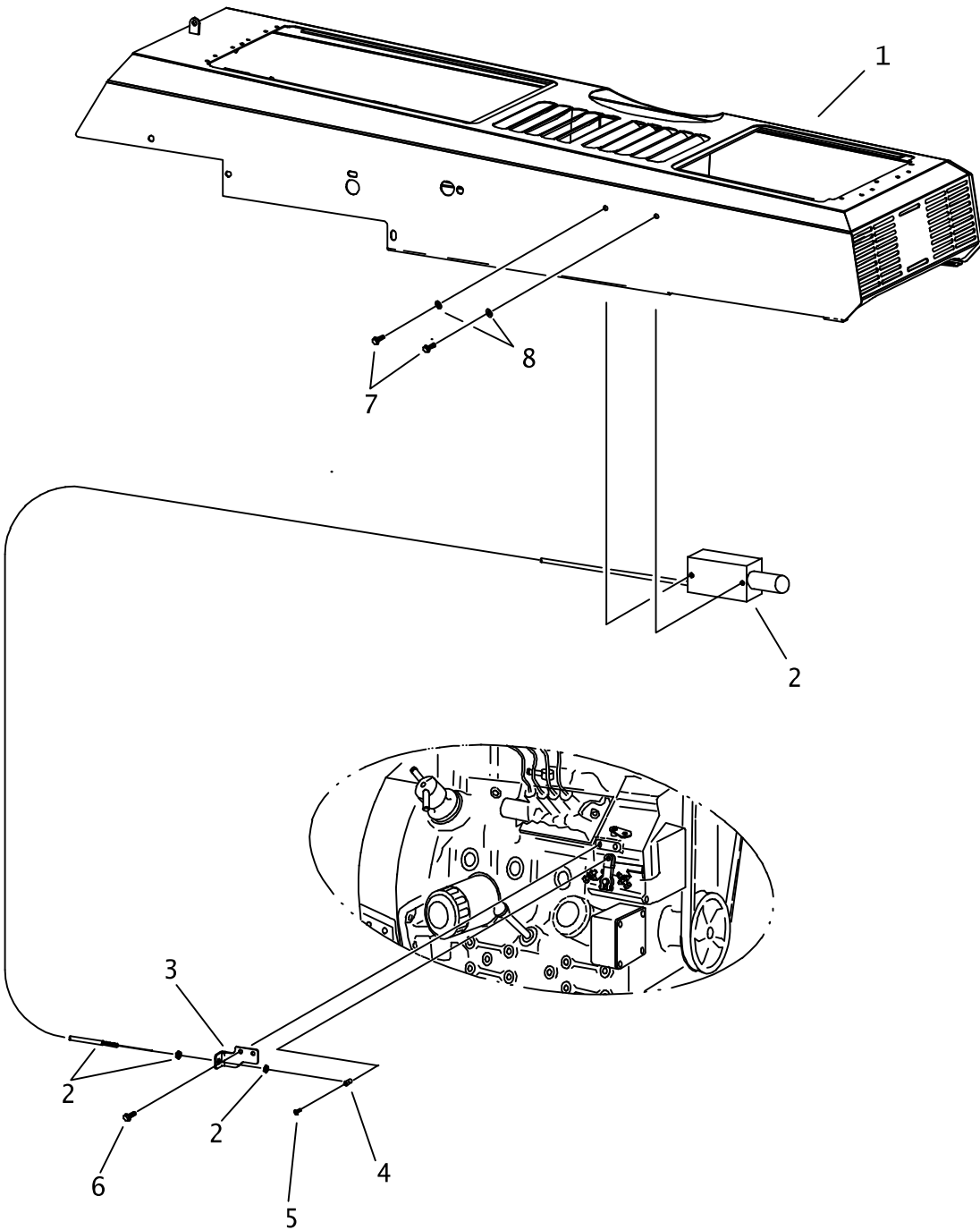

THROTTLE (CATERPILLAR / PERKINS DIESEL)

REF NO.	PART NUMBER	QTY	DESCRIPTION	REMARKS
1.	322-509	-	HOOD	
2.	215-231	1	LINEAR ACTUATOR	
	196-331	-	CABLE (LINEAR ACTUATOR)	
	501-358	-	ROLL PIN (3/32" X 3/4")	
	195-911	-	THROTTLE CABLE	
	196-058	-	CABLE SWIVEL (.081)	
3.	320-826	1	THROTTLE CABLE BRACKET	
4.	179-720	1	THROTTLE CABLE PIN	
5.	106-271	1	SCREW (M5-0.80 X 8MM, PLPS)	
6.	106-224	2	FLG SCREW (M6-1.00 X 10MM)	
7.	105-836	2	FLG LK BOLT (1/4"-NC X 1/2")	
8.	106-076	2	WASHER (1/4")	

FOOTNOTES

NOTE:

B

808-908

FRAME COMPONENTS

DRILL FRAME COMPONENTS

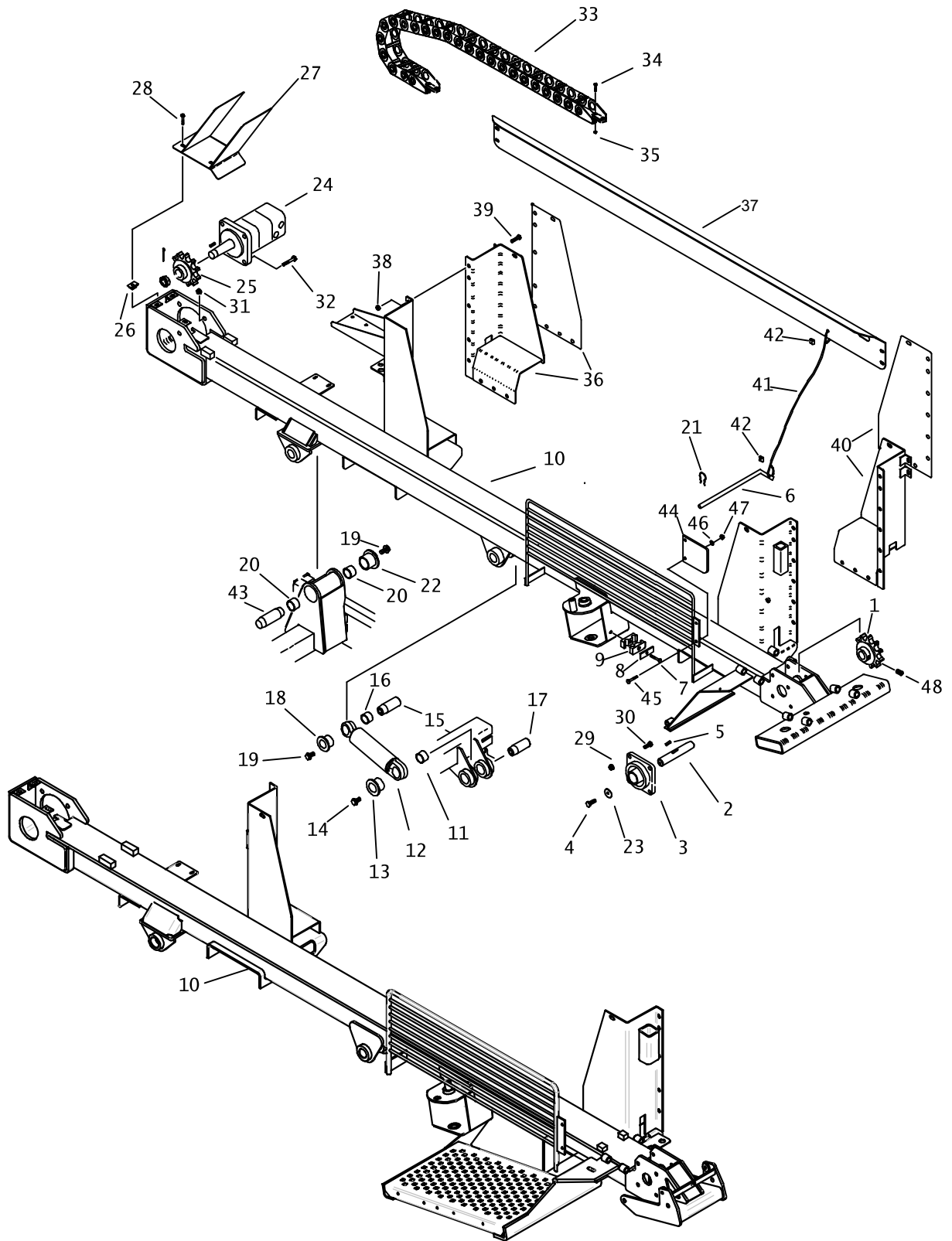

DRILL FRAME COMPONENTS

REF NO.	PART NUMBER	QTY	DESCRIPTION	REMARKS
1.	306-478	1	SPROCKET (120/9T)	BEGINS WITH S/N 253690
2.	183-843	1	ROLLER PIN	
3.	125-614	2	FLANGE BEARING (1.625")	
4.	106-079	2	SCREW (M10-1.50 X 30mm)	
5.	165-963	1	KEY (3/8" X 1-1/8")	
6.	344-751	2	PIN	USE WITH JT92I
	184-711	2	PIN	USE WITH JT92IS
7.	105-883	2	FLG LK BOLT (3/8-NC X 2")	
8.	305-256	2	BACKUP SPACER	
9.	110-270	4	BOLT-ON CLAMP (9/16", HALF)	
10.	309-585	1	WELDMENT, JT920 DRILL FRAME	USE WITH EARLY STYLE JT920
	325-629	1	WELDMENT, JT920 DRILL FRAME	USE WITH JT92I, JT92IL, JT92IP, AND JT92SP
11.	125-773	1	COMPOSITION BUSHING (1.75")	
12.	151-054	1	CYL (3.0" X 1.50" X 4.0")	
13.	181-975	1	TAPERED INSERT (1.75")	
14.	106-470	1	FLG SCREW (M16-2.0 X 40mm)	TORQUE TO 175 FT-LB
15.	179-078	1	TAPERED PIN (1.500" X 4.440")	
16.	125-772	1	COMPOSITION BUSHING (1.5")	
17.	179-037	1	TAPERED PIN (44.45mm X 132mm)	
18.	181-974	1	TAPERED INSERT (1.5")	
19.	105-969	2	FLG BOLT (5/8-NC X 1-1/2", GD8)	PRIOR TO S/N_____, USE 106-470
20.	125-438	2	COMPOSITION BUSHING (1.75")	BEGINS WITH S/N 2V0213
21.	110-033	2	HAIR CLIP PIN (1/8" X 1/2")	
22.	181-975	1	TAPERED INSERT (1.75")	
23.	105-223	2	WASHER (3/8")	
24.	158-908	1	HYD MOTOR (THRUST, 8600#)	
	190-728	-	SEAL REPAIR KIT	
	106-324	-	CASTLE JAM NUT (1-1/2-NF)	SEE FOOTNOTE #1
	166-829	-	KEY (9/16" X 2")	SEE FOOTNOTE #1
	105-501	-	COTTER PIN (.125" X 2")	
25.	174-018	1	SPROCKET (120B9)	BEGINS WITH S/N 253690
26.	106-551	3	CLIP NUT (M8-1.25)	
27.	353-138	1	COVER PLATE	
28.	106-381	3	FLG LK SCREW (M8-1.25 X 25mm)	
29.	106-685	8	LOCKNUT (M12-1.75, PRV TORQ, 10.9)	
30.	106-333	8	SCREW (M12-1.75 X 40mm, 8.8)	
31.	105-357	4	LOCKNUT (5/8-NC)	
32.	105-462	4	BOLT (5/8-NC X 2-1/4")	
33.	346-052	1	HOSE CARRIER	
	118-213	1	HOSE CARRIER	BEGINS WITH S/N
	357-328		UPPER MOUNT BRACKET - LEFT	
	323-902	AR	MOUNTING BRACKET (LH)	BEGINS WITH S/N
	357-329		UPPER MOUNT BRACKET - RIGHT	
	323-903	AR	MOUNTING BRACKET (RH)	BEGINS WITH S/N
	359-944	AR	EASY-OUT BAR (1/2" X 4.00")	
	323-900	AR	EASY-OUT BAR (1/2" X 4.000")	BEGINS WITH S/N
	359-945	AR	ALUMINUM BAR (1/2" X 4.00")	
	323-900	AR	ALUMINUM BAR (1/2" X 4.000")	BEGINS WITH S/N
	359-946	AR	REPAIR SECTION	
	118-214	AR	REPAIR SECTION (4" X 16")	BEGINS WITH S/N
	179-917	AR	4" FLAT ALUMINUM BAR	BEGINS WITH S/N

NOT SHOWN:

FOOTNOTES:

NOTE:

DRILL FRAME COMPONENTS

REF NO.	PART NUMBER	QTY	DESCRIPTION	REMARKS
34.	105-823	8	FLG LK BOLT (5/16-NC X 3/4")	
35.	105-003	8	FLG LOCKNUT (5/16-NC)	
36.	344-800	1	REAR ROD SUPPORT	USE WITH JT921
	344-875	1	SIDE PLATE	USE WITH JT921S
37.	344-878	1	DRILL PIPE GUARD	
38.	106-709	17	FLG LK NUT (M12-1.75)	
39.	106-559	17	SCREW (M12-1.75 X 25mm)	
40.	344-801	1	FRONT ROD SUPPORT	USE WITH JT921
	344-876	1	SIDE PLATE	USE WITH JT921S
41.	110-981	AR	BULK CABLE (1/16", SOLD PER FT)	USE 2 @ 18"
42.	350-275	4	ALUMINUM SLEEVE (1/16")	
43.	178-190	1	BAR (1.75 X 8 TPRD PIN W/CMFR)	BEGINS WITH S/N 2V0213
44.	116-431	1	OUTBOARD SPOILS FLAP	
45.	105-826	2	FLG LK BOLT (3/8-NC X 1")	
46.	105-059	2	WASHER (7/16")	
47.	105-834	2	FLG LOCKNUT (3/8"-NC)	
48.	105-708	1	SET SCREW (3/8-NC X 3/8", NLK)	

NOT SHOWN:

FOOTNOTES:

1. TORQUE CASTLE NUT TO 475 N-M (350 FT-LBS)

NOTE:

FRONT WRENCH

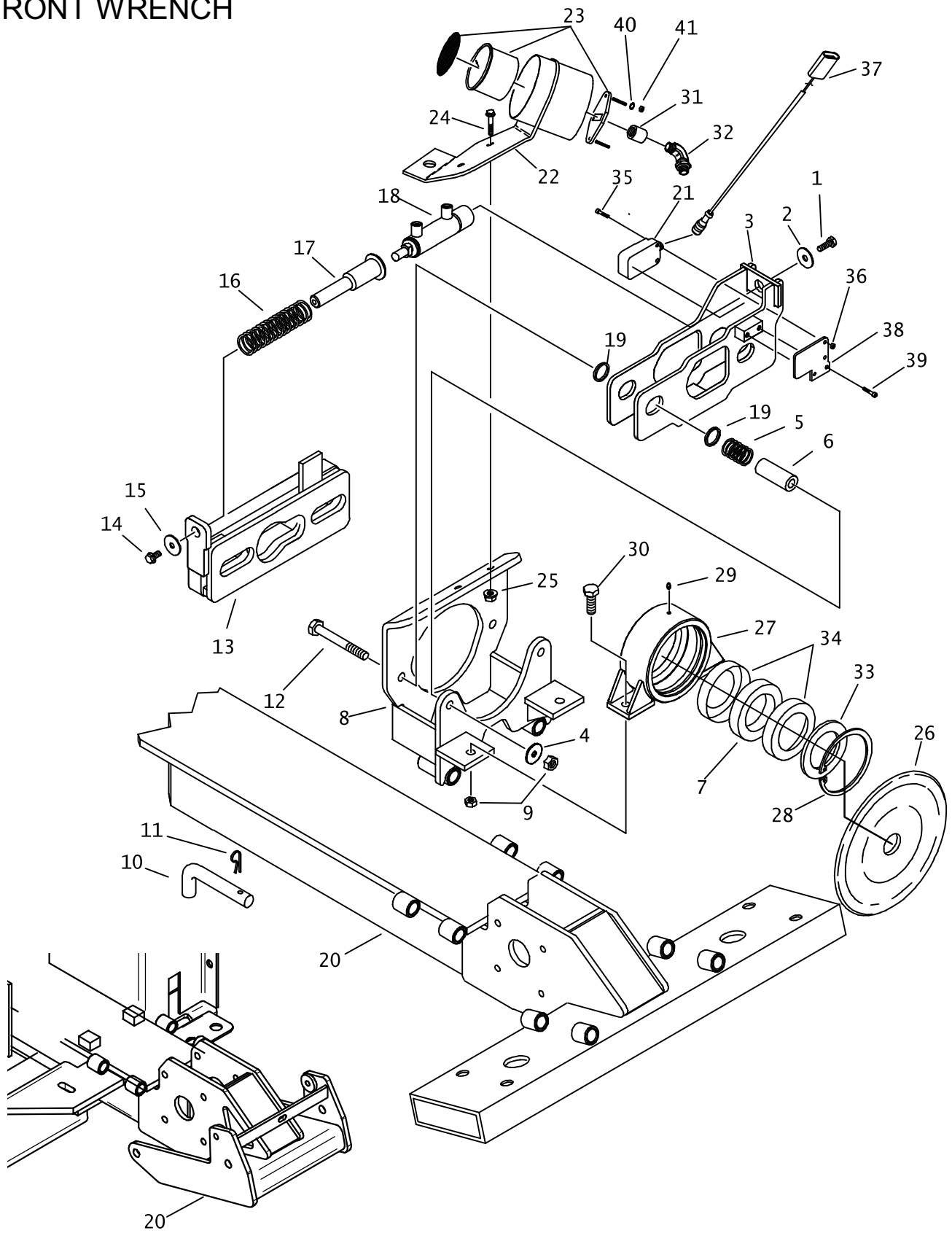

FRONT WRENCH

REF NO.	PART NUMBER	QTY	DESCRIPTION	REMARKS
1.	106-806	1	FLG LK SCREW (M12-1.75 X 25mm)	
2.	106-397	1	WASHER (M12, HARDENED)	
3.	307-806	1	SLIDE PLATE	
4.	105-059	2	WASHER (7/16")	
5.	117-017	2	COMPRESSION SPRING	
6.	183-966	2	BUSHING (.530" X 1" X 3.6")	
7.	307-884	1	PIPE GUIDE BEARING	
8.	301-973	1	FRONT WRENCH SUPPORT	
9.	106-685	4	LOCKNUT (M12-1.75, PRV TRQ, 10.9)	
10.	183-818	4	PIN (19mm X 220mm)	
11.	110-033	4	CLIP PIN (1/8" X 1/2")	
12.	106-618	2	SCREW (M12-1.75 X 130mm)	
13.	305-678	1	WRENCH PLATE	
14.	106-380	1	FLG LK SCREW (M8-1.25 X 16mm)	
15.	106-260	1	WASHER (3/8")	
16.	117-052	1	COMPRESSION SPRING	
17.	184-945	1	SPRING GUIDE	
18.	150-725	1	CYLINDER (1" X 2.5") STROKE THRD	
19.	110-078	4	MACHINERY BUSHING (1",14 GA)	
20.	346-800	-	10'DRILL FRAME	USED ON JT920L
	309-585	-	WELDMENT, JT920 DRILL FRAME	USED ON JT920.
	325-629	-	WELDMENT, JT920 DRILL FRAME	USED ON JT921, JT921S, JT921P & JT92SP
21.	214-692	1	PROXIMITY SWITCH	
22.	346-726	1	GAUGE MOUNT ASS'Y	OBSOLETE
23.	191-047	1	GAUGE KIT	
24.	105-826	2	FLG LOCK BOLT (3/8-NC X 1")	
25.	105-834	2	FLG LOCKNUT (3/8-NC)	
26.	149-578	1	ROD WIPER	
27.	307-665	1	PIPE GUIDE	
28.	115-505	1	INTERNAL SNAP RING (5.118")	
29.	115-001	1	ZERK (02N)	
30.	106-333	2	SCREW (M12-1.75 X 40mm)	
31.	115-170	1	COLLAR (04NF)	
32.	154-482	1	CONNECTOR (04N-04090)	
33.	107-453	1	RETAINER RING	
34.	305-866	2	GUIDE BEARING	
35.	106-427	2	SCREW (M5-0.80 X 22MM, SOC)	
36.	106-850	2	LOCKNUT (M5-0.80)	
37.	214-691	1	STRAIGHT JUMPER HARNESS	
38.	308-946	1	SHEET, WRENCH MOUNT BOLT-ON MNT	
39.	106-428	2	SCREW (M5-0.80 X 14MM,SOC)	
40.	106-205	1	WASHER (.191")	
41.	106-138	1	NUT (M5-0.80)	

NOT SHOWN:

FOOTNOTES:

NOTE:

CARRIAGE

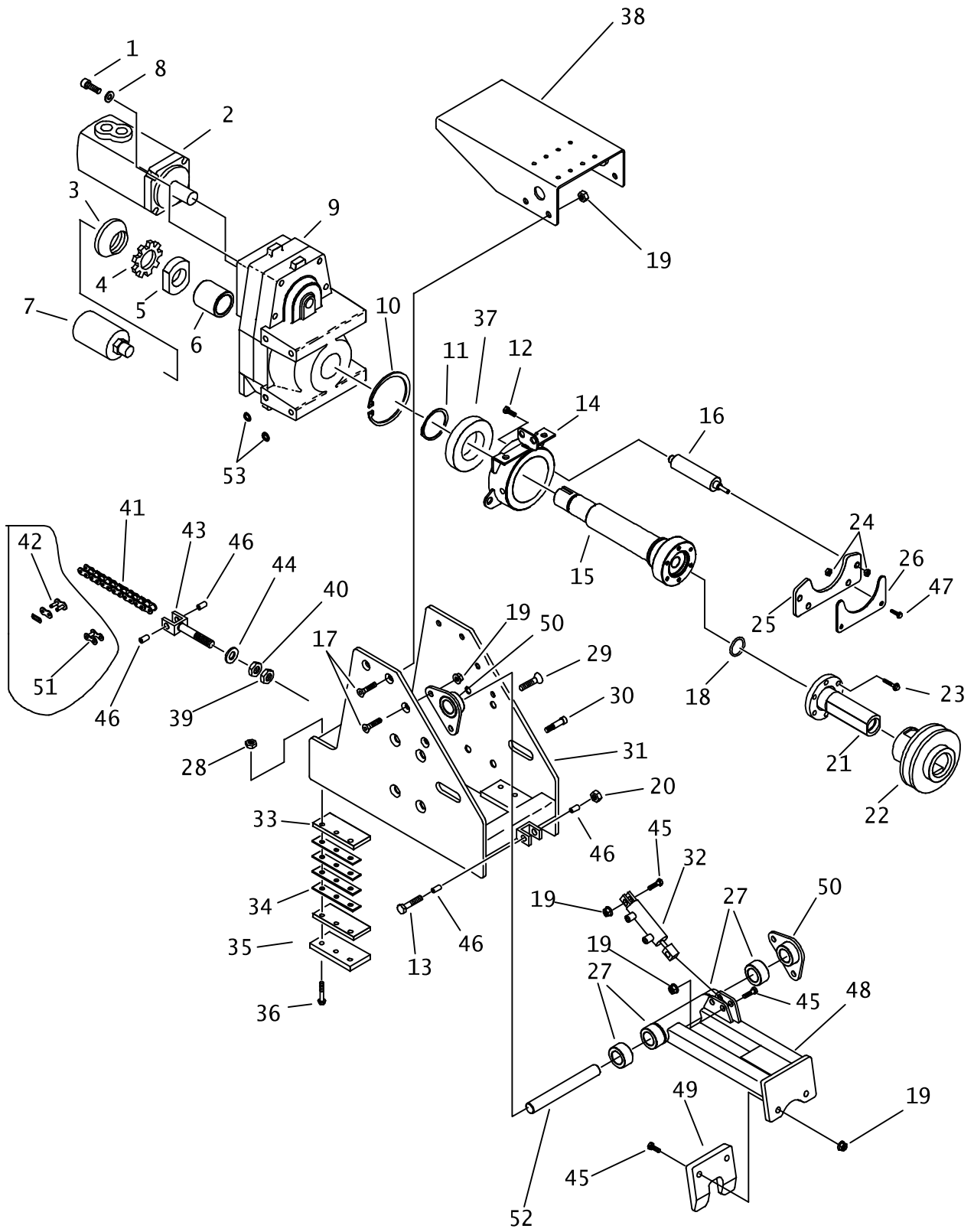

CARRIAGE

REF NO.	PART NUMBER	QTY	DESCRIPTION	REMARKS
1.	107-044	4	BOLT (M12-1.75 X 40mm, SOC)	USE 242 LOCTITE THREAD LOCKER
2.	158-881	1	HYD MOTOR	USE 518 LOCTITE FLANGE SEALANT
	500-641		MOUNTING FLANGE	
	500-711		SEAL REPAIR KIT - REAR	
	500-758		SEAL REPAIR KIT SHAFT	
3.	185-067	1	THRUST LOCKNUT(1.767-NF-18)	
4.	185-074	1	TANG LOCK WASHER (1.792")	
5.	106-865	1	NUT (3.25")	
6.	184-749	1	SPACER	
7.	153-242	1	WATER SWIVEL	
8.	106-397	4	WASHER (M12, HARDENED)	
9.	166-113	1	GEARBOX (1.78:1, ROTATION)	1.78:1 ROTATION DRIVE
10.	115-534	1	INTERNAL SNAP RING (5.485")	
11.	118-033	1	EXTERNAL SNAP RING (2.5")	
12.	106-806	2	FLG LK SCREW (M12-1.75X25mm)	
13.	107-035	2	BOLT (7/16-NC X 3",GD8)	
14.	343-192	1	BEARING HOUSING	
15.	347-605	1	SLIDING SPINDLE SHAFT	
16.	150-724	2	CYL (1" X 2")	
17.	106-660	8	SCREW (M12-1.75 X 30mm, SOC)	
18.	157-019	1	O-RING (139 D90)	
19.	106-685	14	LOCKNUT (M12-1.75, PRV TRQ, 10.9)	
20.	105-151	2	LOCKNUT (7/16-NC)	
21.	301-891	1	SAVER SUB (1.41-6 FM DS)	
22.	353-763	1	WRENCH COLLAR	
23.	106-081	6	SCREW (M10-1.5 X 35mm, 12.9)	USE 242 LOCTITE TORQUE TO 55 FT. LBS
24.	106-031	4	LOCKNUT (M12-1.75, NLK)	
25.	344-574	1	PUSH PLATE	
26.	344-761	2	WEAR PAD	
27.	125-770	4	COMPOSITION BUSHING (1")	
28.	105-894	12	LOCKNUT (M10-1.50,PRV TRQ,10.9)	
29.	107-045	8	SCREW (M16-2.0 X 35mm, 10.9)	
30.	107-043	2	SHLD BOLT (M12 X 35mm, M10-1.5)	
31.	306-489	1	WELDMENT, JT920L CARRIAGE 120P	
32.	150-723	1	CYL (1" X 2")	
33.	343-046	8	SLIDE	
34.	343-047	16	SPACER	
35.	343-038	4	CLAMP PLATE	
36.	106-332	12	SCREW (M10-1.5 X 70mm)	
37.	125-117	1	BALL BEARING (1.125")	
38.	346-738	1	LOWER HOSE TRACK MOUNT	

NOT SHOWN:

FOOTNOTES:

NOTE:

CARRIAGE

REF NO.	PART NUMBER	QTY	DESCRIPTION	REMARKS
39.	105-338	1	LOCKNUT (3/4-NC)	
40.	105-351	1	HEX NUT (3/4-NC)	
41.	130-526	1	ROLLER CHAIN (#120, 215P)	THIS ITEM IS USED ON JT920L ONLY
	129-006	1	ROLLER CHAIN #120 171P	
42.	130-524	2	CONNECTOR LINK (#120H) (REX)	
43.	343-053	1	CHAIN ADJUSTER	
44.	105-384	2	WASHER (3/4")	
45.	106-334	4	SCREW (M12-1.75 X 50mm)	
46.	343-058	4	BUSHING	
47.	105-273	2	SCREW (M12-1.75 X 30mm)	
48.	346-730	1	BACK AUX WRENCH	
49.	346-729	1	BACKUP WRENCH	
50.	346-737	2	AUXILIARY WRENCH MOUNT	
51.	130-530	1	OFFSET LINK (#120H)	
52.	346-763	1	PIN	
53.	110-095	AR	MACHINERY BUSHING (3/4" X 18GA)	

NOT SHOWN:

FOOTNOTES:

NOTE:

ROTATION GEARBOX

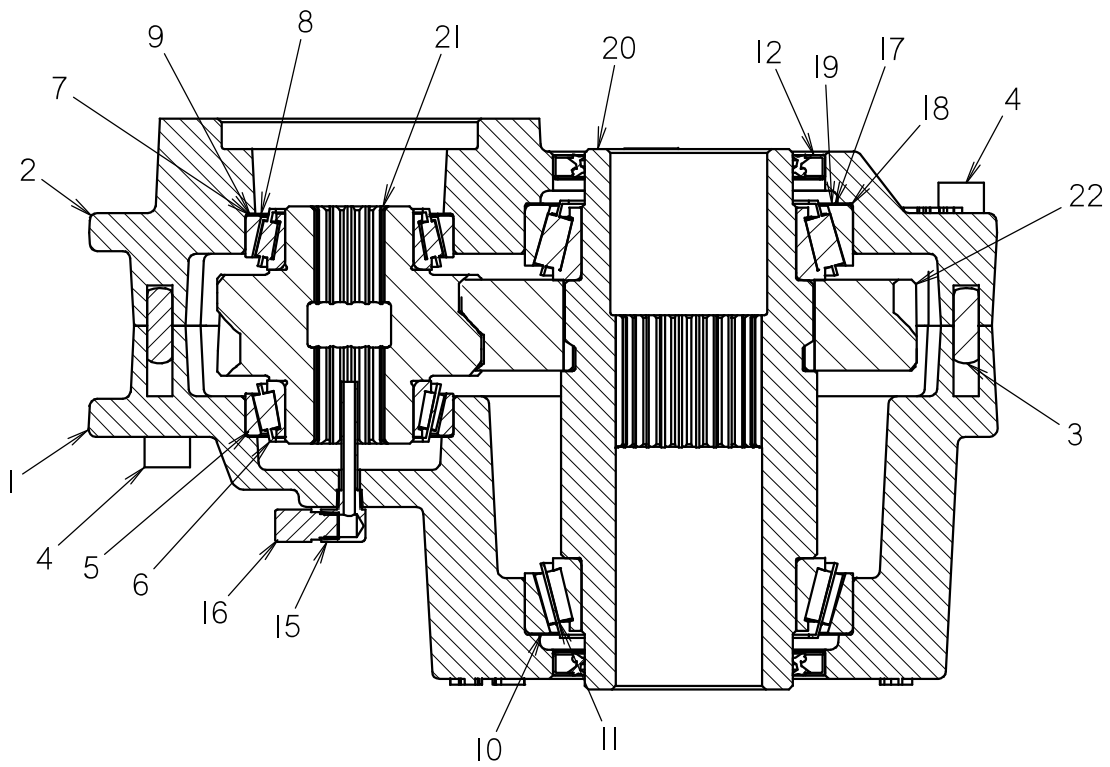
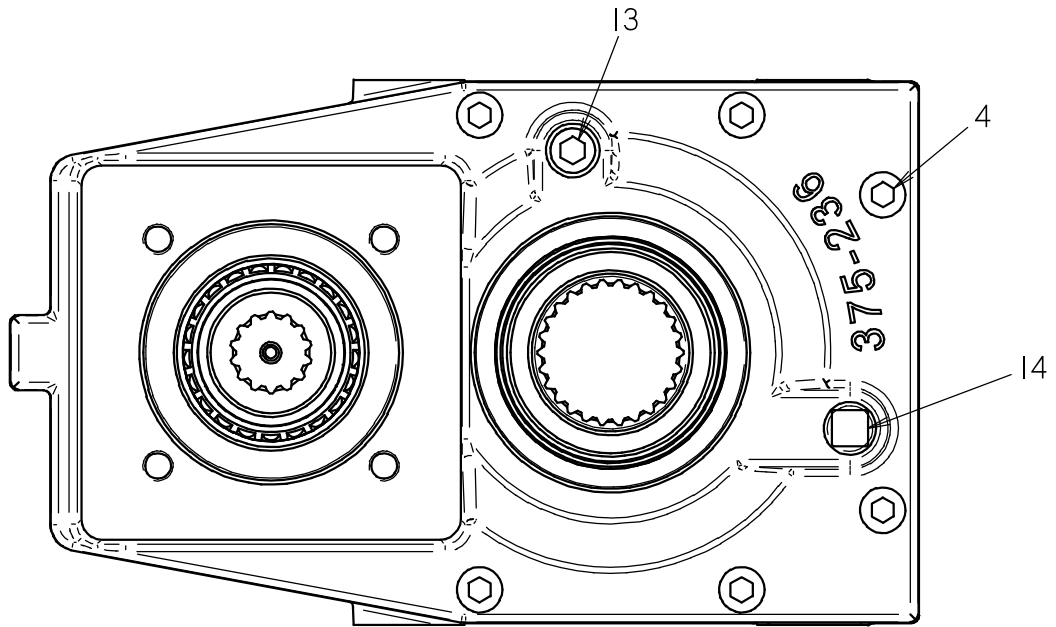

ROTATION GEARBOX

REF NO.	PART NUMBER	QTY	DESCRIPTION	REMARKS
	166-113		GEAR BOX (1.781, ROTATION)	
1	162-002	1	GEARBOX HOUSING	
2	162-001	1	COVER "B"	
3	106-866	2	DOWEL PIN (M10 X 30MM)	
4	106-771	10	SCREW (M12-1.75 X 60MM, SOC)	
5	126-099	2	TAPERED RACE (3.25")	
6	126-100	2	BEARING CONE	
7	165-800	5	SHIM (.002")	
8	165-801	5	SHIM (.003")	
9	165-802	5	SHIM (.007")	
10	126-076	2	TAPERED RACE (5.118")	
11	126-075	2	TAPERED BEARING (3.346")	
12	155-869	2	INTERNAL SEAL (3.250")	
13	115-165	1	PLUG (O8N, SOC)	
14	115-211	1	PLUG (O8N, SQ, MAG)	
15	514-123	1	PICKUP TUBE (O2N-O2NF90-2")	
16	159-003	1	AIR VENT (O2N)	
17	165-828	5	SHIM	
18	165-829	5	SHIM	
19	165-830	5	SHIM	
20	162-003	1	OUTPUT SHAFT	
21	165-187	1	INPUT PINION	
22	165-188	1	OUTPUT GEAR	

NOT SHOWN:

FOOTNOTES:

NOTE:

TRACK GROUP

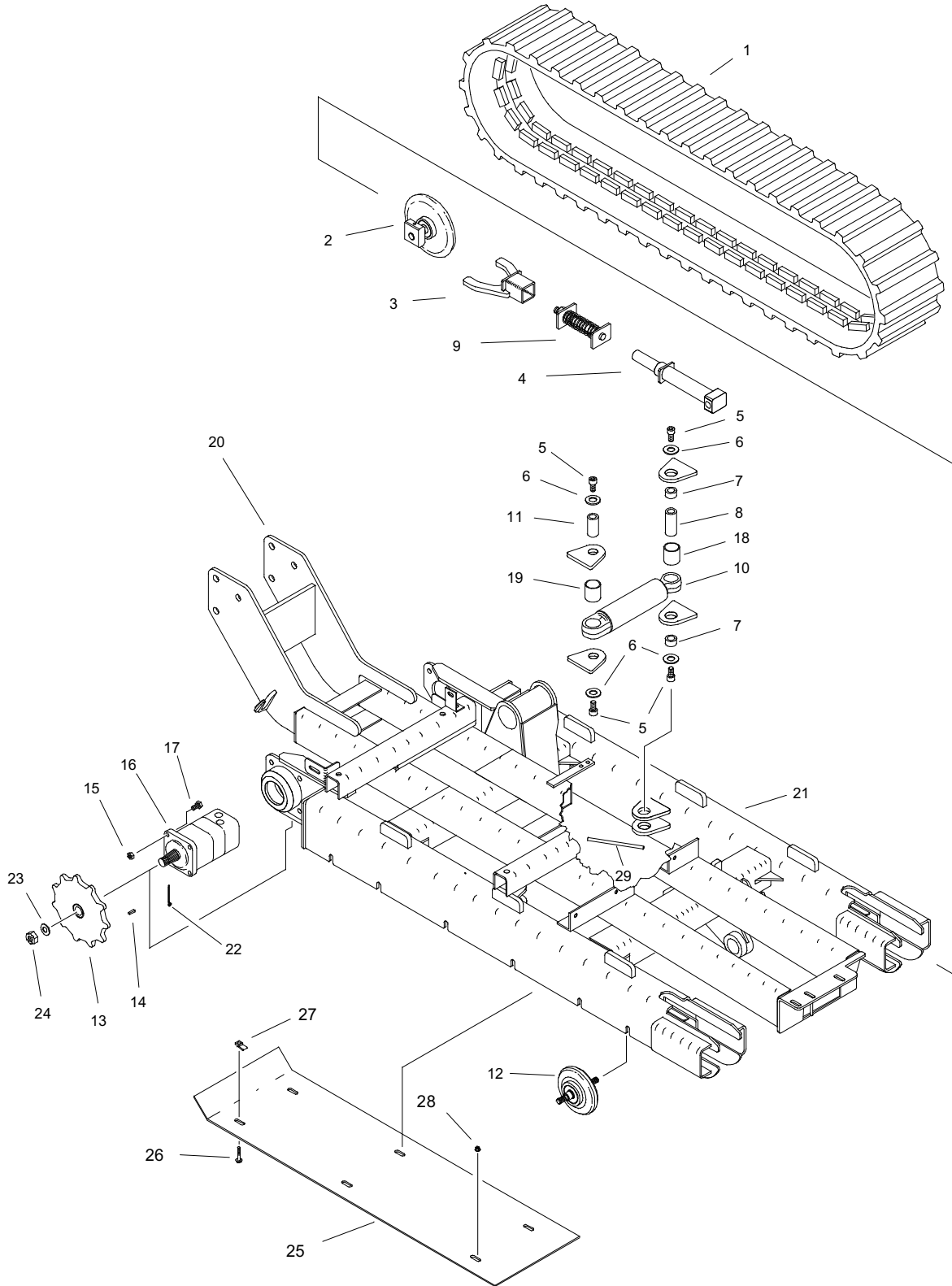

TRACK GROUP

REF NO.	PART NUMBER	QTY	DESCRIPTION	REMARKS
1.	353-784	2	RUBBER TRACK (230MM, 56P, 72MM)	
2.	347-019	2	IDLER	
3.	356-272	2	YOKE	
4.	356-273	2	GREASE CYLINDER	
5.	105-248	4	SCREW (M12-1.75 X 25MM,SOC)	
6.	105-475	4	WASHER (1/2")	
7.	184-540	2	SPACER	
8.	183-975	1	PIN (25.4MM X 68MM)	
9.	356-271	2	JT3510 SPRING ASS'Y	
10.	151-076	1	CYL (2.0" X 1.00" X 10.00")	
11.	183-901	1	PIN (31.8MM X 68M)	
12.	355-972	12	ROLLER	
13.	302-917	2	WELDMENT MOTOR SPROCKET	
14.	166-846	2	WOODRUFF KEY (5/16" X 1")	
15.	105-065	8	LOCKNUT (1/2-NC)	
16.	158-826	2	HYDRAULIC MOTOR (GEROLER)	
	157-701		SHAFT SEAL	
17.	106-197	8	BOLT (1/2-NC X 2-1/2", GD8)	
18.	125-770	1	COMPOSITION BUSHING (1")	
19.	125-771	1	COMPOSITION BUSHING (1.25")	
20.	309-584	1	WELDMENT, JT920 TRACK FRAME	
21.	353-629	1	TRACK FRAME	
22.	105-518	2	COTTER PIN (1/8" X 1-1/2")	
23.	106-488	2	WASHER (M24, HARDENED)	
24.	107-034	2	CASTLE NUT (1-20 NEF)	TIGHTEN TO 250-350 FT-LBS
25.	344-577	1	SKID PLATE	
26.	106-381	6	FLG LK SCREW (M8-1.25 X 25MM)	
27.	106-551	4	CLIP NUT (M8-1.25)	
28.	106-386	2	FLG LOCKNUT (M8-1.25)	
29.	115-704	AR	BULK EDGE (1/4", SOLD PER 1")	USE 9"

NOT SHOWN:

FOOTNOTES:

NOTE:

FUEL RESERVOIR

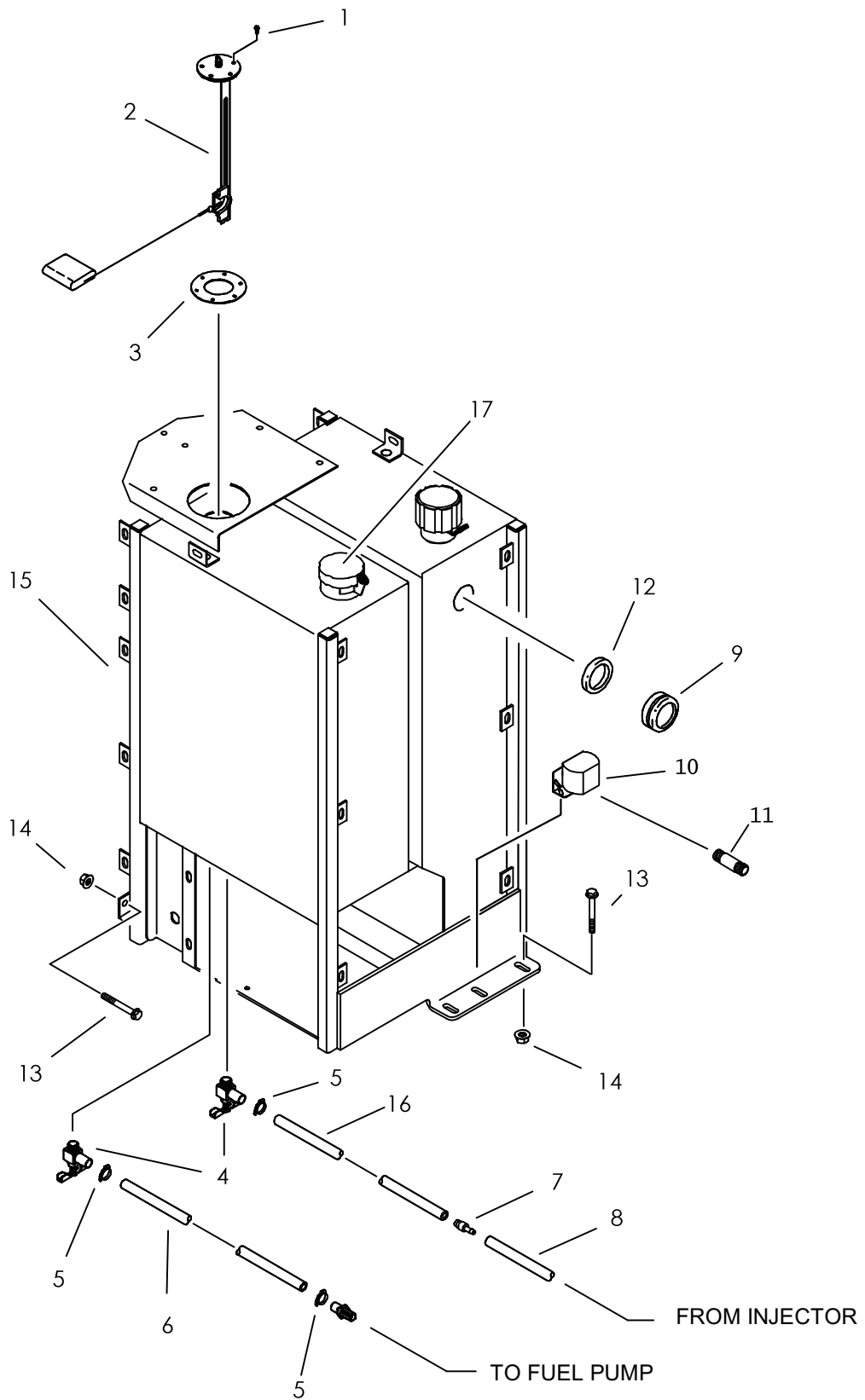

FUEL RESERVOIR

REF NO.	PART NUMBER	QTY	DESCRIPTION	REMARKS
1.	105-214	5	FLG SCREW (#10-24 X 1/2")	
2.	217-549	1	FUEL SENDER	
3.	165-704	1	GASKET	
4.	156-239	2	S/O SHUT-OFF (02N-05H90)	
5.	110-249	4	WORM CLAMP (1/4" TO 5/8")	
6.	116-108	AR	BULK HOSE (5/16", SOLD PER 1")	USE 32"
7.	156-253	1	S/O COUPLER (03H-05H)	
8.	116-624	AR	BULK HOSE (5/32", SOLD PER 1")	USE 32"
9.	116-218	1	SIGHT GLASS (2")	
10.	306-602	1	ALARM	
11.	216-026	AR	FLEX GUARD (1/4", SOLD PER 1")	USE 9 1/2"
12.	115-320	1	GROMMET (1-1/2")	
13.	106-381	6	FLG LK SCREW (M8-1.25 X 25MM)	
14.	106-386	6	FLG LOCKNUT (M8-1.25)	
15.	350-503	1	MOBILING STATION	
16.	116-108	AR	BULK HOSE (5/16", SOL PER 1")	USE 3"
17.	111-004	1	FUEL FILLER NECK	
	111-065		FUEL CAP LOCKING, VENTED	

FOOTNOTES

NOTE:

H

804-740

COVERS (CATERPILLAR DIESEL)

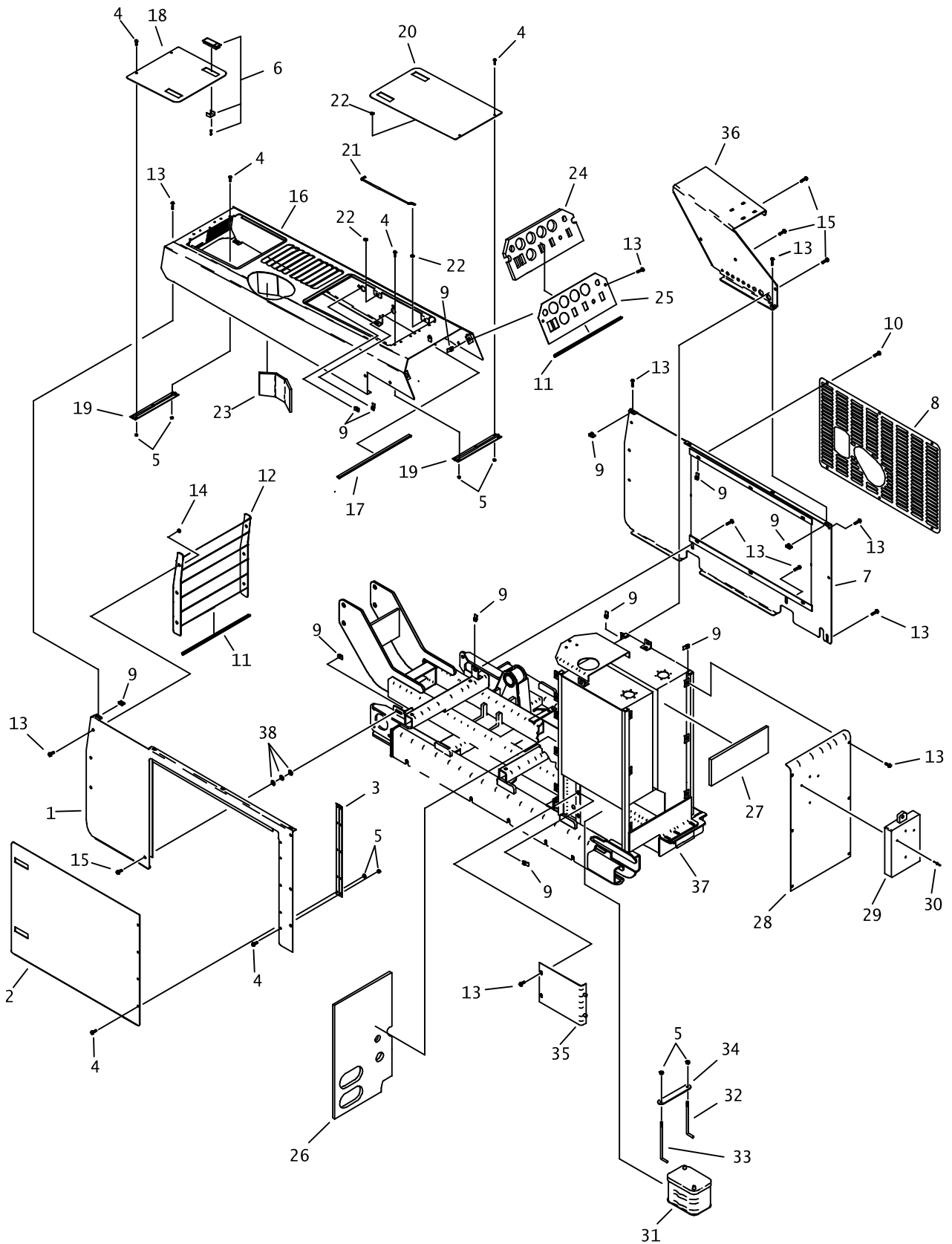

COVERS (CATERPILLAR DIESEL)

REF NO.	PART NUMBER	QTY	DESCRIPTION	REMARKS
1.	322-521	1	COVER PANEL - RIGHT WELDMENT	
2.	322-525	1	ACCESS DOOR	
3.	110-582	1	HINGE (20.5")	
4.	105-836	20	FLG LOCK BOLT (1/4-NC X 1/2")	
5.	105-832	22	FLG LOCKNUT (1/4-NC)	
6.	117-558	6	ADJUST LEVR LATCH (LOCKING)	
	214-961	-	KEY, PAIR (BASE CODE)	
	217-309	-	LOCK PLUG 4/LATCH (BASE CODE)	
	110-596	-	KEYS (PAIR)	
7.	322-517	1	COVER PANEL - LEFT WELDMENT	
8.	323-844	1	ACCESS PANEL	
9.	106-551	37	CLIP NUT(M8-1.25)	
10.	106-162	6	FLG SCREW (M8-1.25 X 20MM, GD8)	
11.	115-686	AR	BULK EDGE (5/32", SOLD PER 1")	USE 2 @ 18"
12.	353-613	1	LOUVER	
13.	107-095	34	FLG LK SCREW (M8-1.25 X 16MM)	
14.	106-386	6	FLG LOCKNUT (M8-1.25)	
15.	106-991	27	FLG LK SCREW (M8-1.25 X 20MM)	
16.	322-509	1	HOOD	
17.	115-686	AR	BULK EDGE (5/32", SOLD PER 1")	USE 1 @ 31"
18.	323-198	1	ACCESS PANEL	
19.	110-794	2	HINGE (11.39")	
20.	323-196	1	ACCESS PANEL	
21.	179-825	1	PROP ROD	
22.	118-211	3	GROMMET (1/4")	
23.	118-146	1	SOUND INSULATION	
24.	118-144	1	SOUND INSULATION	
25.	320-619	1	INSTRUMENT PANEL	
26.	118-143	1	SOUND INSULATION	
27.	118-145	1	SOUND INSULATION	
28.	353-305	1	TANK COVER	
29.	250-622	1	MANUAL COMPARTMENT	
30.	110-560	4	POP RIVET (3/16" X 1/2", ALUM)	
31.	215-244	1	BATTERY (12V, 800 AMP)	
32.	184-723	1	BATTERY BOLT	
33.	183-934	1	BATTERY BOLT	
34.	353-709	1	BATTERY HOLDER	
35.	353-154	1	BATTERY COVER	
36.	322-612	1	HOSE TRACK STAND	
37.	350-503	-	MOBLING STATION	
38.	105-117	3	WASHER (5/16")	

NOT SHOWN:

FOOTNOTES:

NOTE:

REAR STABILIZER

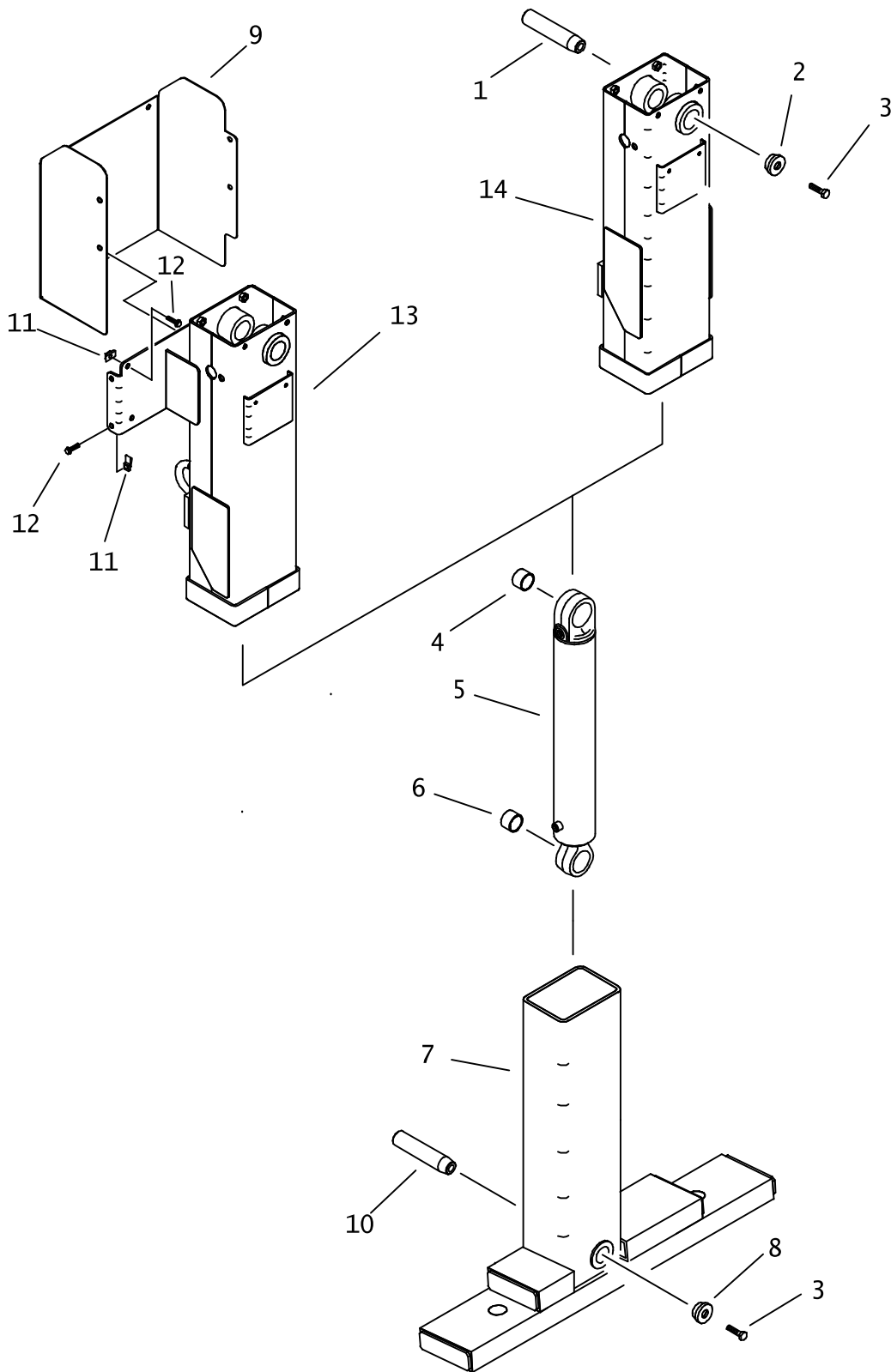

REAR STABILIZER

REF NO.	PART NUMBER	QTY	DESCRIPTION	REMARKS
1.	179-052	1	TAPERED PIN (1.75" X 6.6")	
2.	181-975	1	TAPERED INSERT (1.75")	W/O WATER TANK
3.	105-969	2	FLG BOLT (5/8-NC X 1-1/2", GD8)	
4.	125-773	1	COMPOSITION BUSHING (1.75")	
5.	151-147	1	CYL (3" X 1.5" X 20") 32"	BEGINS WITH S/N 2M2288
6.	125-772	1	COMPOSITION BUSHING (1.5")	
7.	353-291	1	STABILIZER BASE	BEGINS WITH 2M2288
8.	181-974	1	TAPERED INSERT (1.5")	
9.	353-598	1	VALVE ENCLOSURE	W/O WATER TANK
10.	179-033	1	TAPERED PIN (1.5" X 5.4")	WITH WATER TANK
11.	106-551	8	CLIP NUT (M8-1.25)	
12.	106-381	8	FLG LK SCREW (M8-1.25 X 25MM)	
13.	353-289	1	UPPER STABILIZER TUBE	W/O WATER TANK
14.	353-290	1	UPPER STABILIZER TUBE (WET)	WITH WATER TANK - ENDS W/ SN 2M2287

FOOTNOTES

NOTE:

F

803-579

IDLER

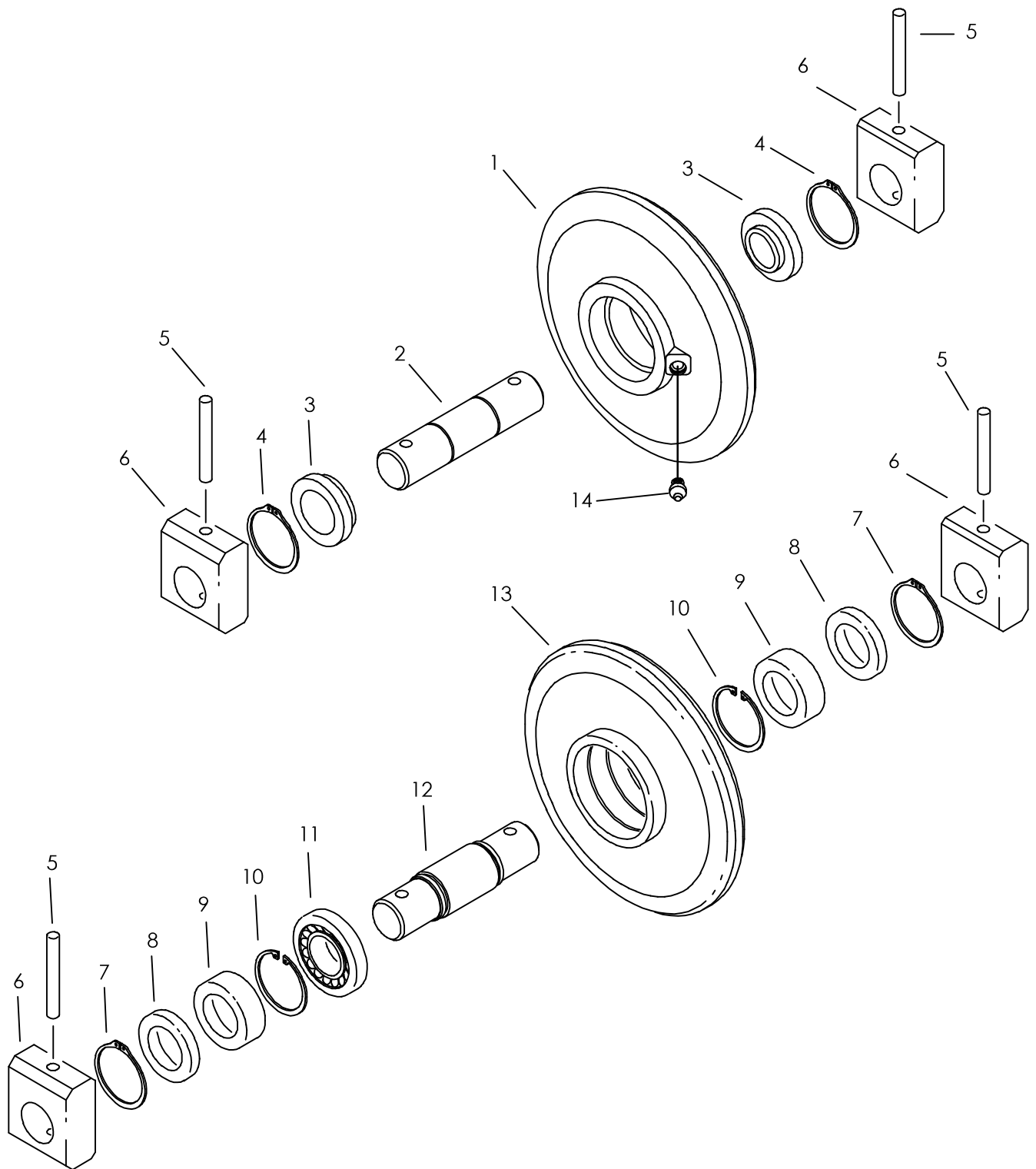

IDLER

REF NO.	PART NUMBER	QTY	DESCRIPTION	REMARKS
1.	347-019	1	IDLER	SEE FOOTNOTES 1 & 3
2.	167-340	1	IDLER SHAFT	
3.	125-550	2	BALL BEARING (1.378") GREASABLE	
4.	115-465	2	EXTERNAL SNAP RING (1.375")	
5.	105-561	2	ROLL PIN (3/8" X 2-3/4")	
6.	347-023	2	PUSH BLOCK	
7.	118-021	2	EXTERNAL SNAP RING (1.500")	
8.	110-478	2	MACHINERY BUSHING (1.585")	
9.	157-650	2	INTERNAL SEAL (1.574")	
10.	115-464	2	INT SNAP RING (3.149")	
11.	125-107	1	BALL BEARING (1.574")	
12.	347-024	1	IDLER SHAFT	
13.	375-277	1	IDLER	SEE FOOTNOTE 2
14.	115-001	1	ZERK (02N)	

NOT SHOWN:

FOOTNOTES:

NOTE:

1. REF NO'S 1 - 6 & 14, NEW STYLE (DOUBLE BEARING)
2. REF NO'S 5 - 13 OLD STYLE (SINGLE BEARING)
3. AFTER ASSEMBLY, ADD GREASE TO IDLER.

TENSION SPRING

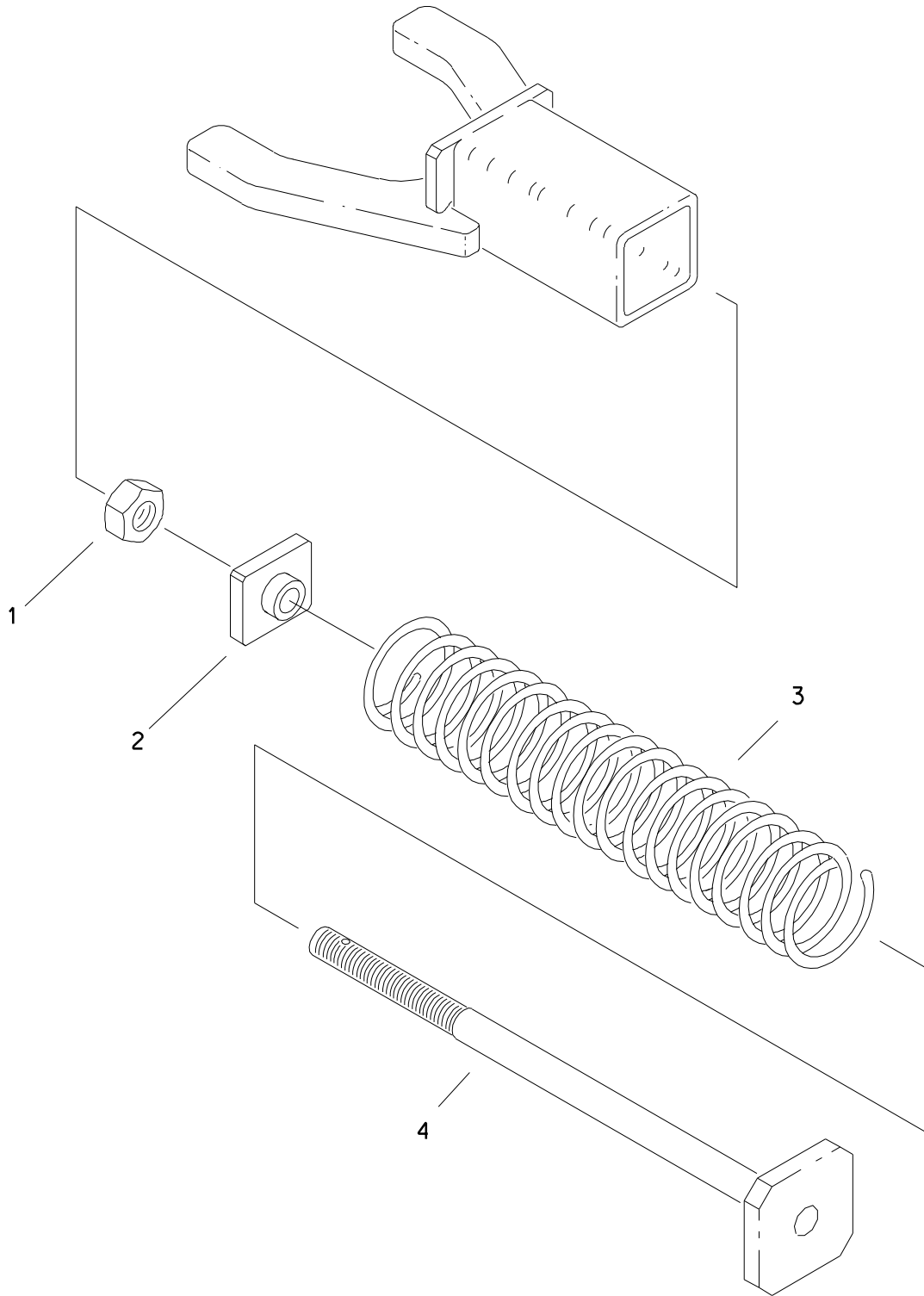

TENSION SPRING

REF NO.	PART NUMBER	QTY	DESCRIPTION	REMARKS
	356-271		SPRING	INCL REF NO.'S 1 THRU 4
1.	106-851	1	LOCKNUT (M18-2.5)	
2.	347-035	1	END PLATE	
3.	117-057	1	TRACK SPRING	
4.	347-034	1	SHAFT	

FOOTNOTES

GREASE CYLINDER

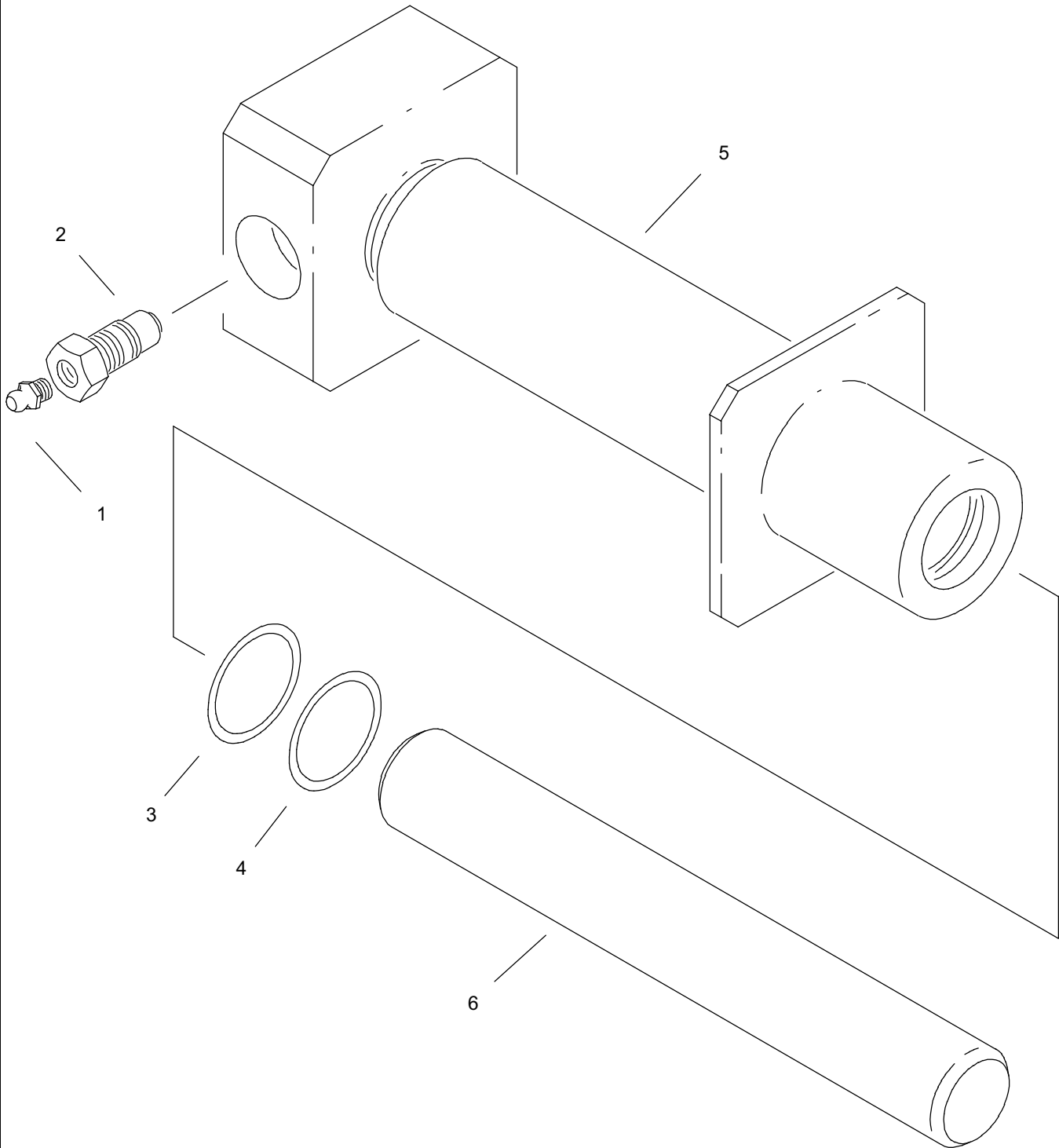

GREASE CYLINDER

REF NO.	PART NUMBER	QTY	DESCRIPTION	REMARKS
	151-177		GREASE CYLINDER	INCL REF NO'S 3 - 6; SEE FOOTNOTE 1
	356-971		GREASE CYLINDER PARTS ASS'Y	EARLY STYLE
	356-273		GREASE CYLINDER	USE ON 921 ONLY
1.	115-019	1	ZERK (02N)	
2.	159-093	1	RELIEF VALVE (5/8-NF,02N)	
3.	157-078	1	O-RING (222 D90)	
4.	155-712	1	BACKUP RING (222 D90)	
5.	356-970	1	GREASE CYLINDER BARREL	
	347-038	1	GREASE CYLINDER WELDMENT	USE ON 921 ONLY
6.	356-969	1	GREASE CYLINDER ROD	
	347-039	1	GREASE CYLINDER ROD	USE ON 921 ONLY

NOT SHOWN:

FOOTNOTES:

NOTE:

NOTES:

OPERATOR'S STATION

SEAT MOUNT

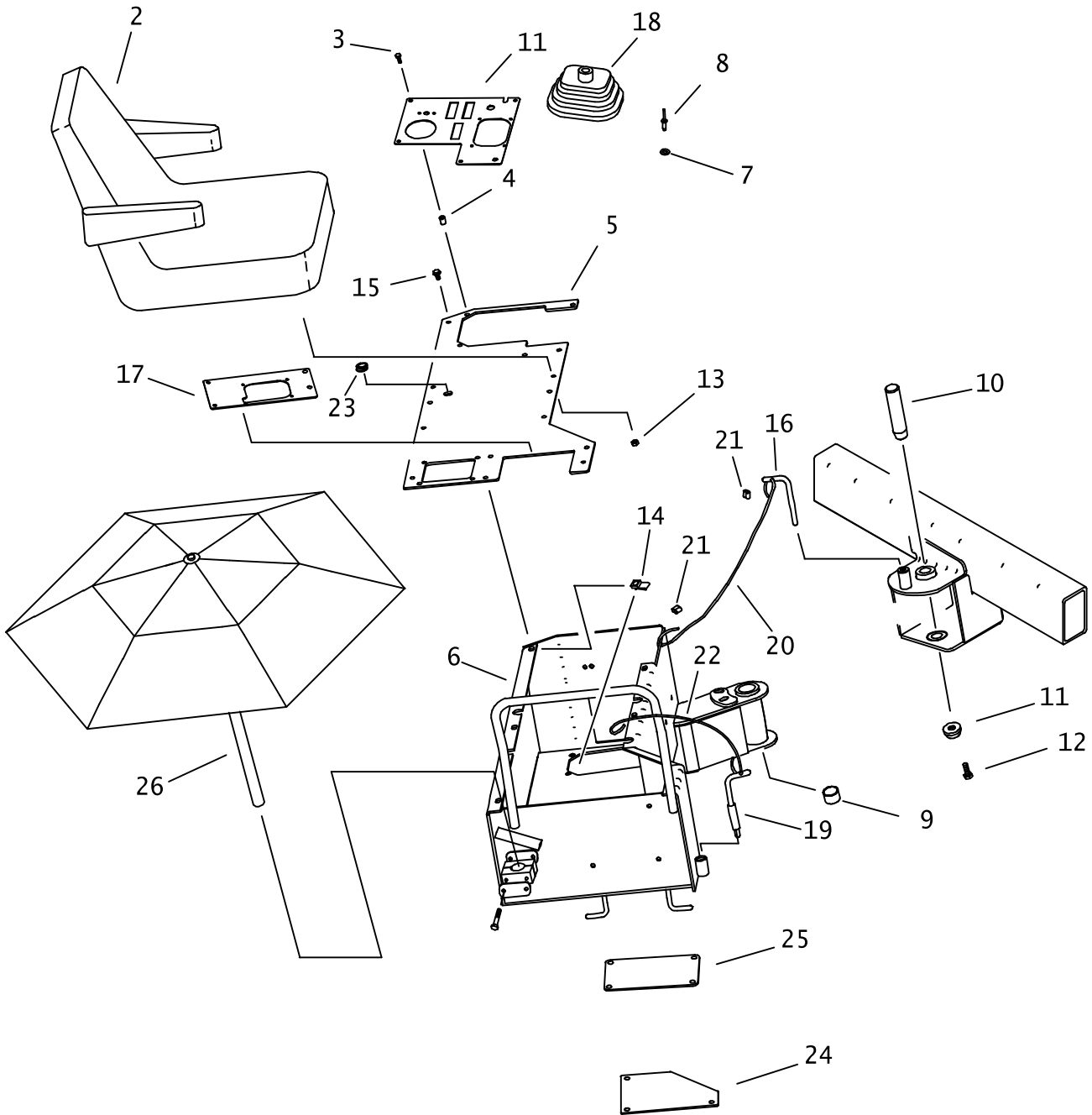

SEAT MOUNT

REF NO.	PART NUMBER	QTY	DESCRIPTION	REMARKS
1.	344-714	1	COVER PLATE	
2.	117-402	1	SEAT/ARM REST	
	117-230	1	SEAT W/O ARM REST	
	190-884	-	ARMREST KIT	
	344-758	-	GUIDE BAR	
3.	106-640	8	SCREW (M6-1 X 20mm, SOC BUT)	
4.	106-670	8	NUTSERT (M6-1.00)	
5.	353-626	1	TOP PLATE	
6.	353-617	1	SEAT PIVOT	
7.	106-205	8	WASHER (3/16")	
8.	110-348	8	POP RIVET (3/16" X .664")	
9.	125-800	2	COMPOSITION BUSHING (1.000")	
10.	184-609	1	PIN (25.4MM X 190MM)	
11.	181-981	1	TAPERED INSERT (1.000")	
12.	106-079	1	SCREW (M10-1.50 X 30MM)	
13.	105-003	4	FLG LOCKNUT (5/16-NC)	
14.	106-551	12	CLIP NUT (M8-1.25)	
15.	106-381	12	FLG LK SCREW (M8-1.25 X 25mm)	
16.	184-806	1	SEAT LATCH PIN (1/2" X 5.8")	
17.	353-242	1	TOP PLATE	
18.	353-243	2	SHIFTER BOOT (RUBBER)	
19.	178-145	1	PIN	
20.	110-981	AR	BULK CABLE (1/16", SOLD PER 1")	USE 10"
21.	350-275	4	ALUMINUM SLEEVE (1/16")	
22.	110-981	AR	BULK CABLE (1/16")	USE 12"
23.	115-349	1	GROMMET (1/2", SOLD PER 1")	
24.	307-984	1	ACCESS PANEL	
25.	337-479	1	COVER PLATE	
26.	344-0001	1	UMBRELLA (16")	
	500-1962	-	UMBRELLA POLE	

NOT SHOWN:

FOOTNOTES:

NOTE:

OPERATORS STATION GAUGES

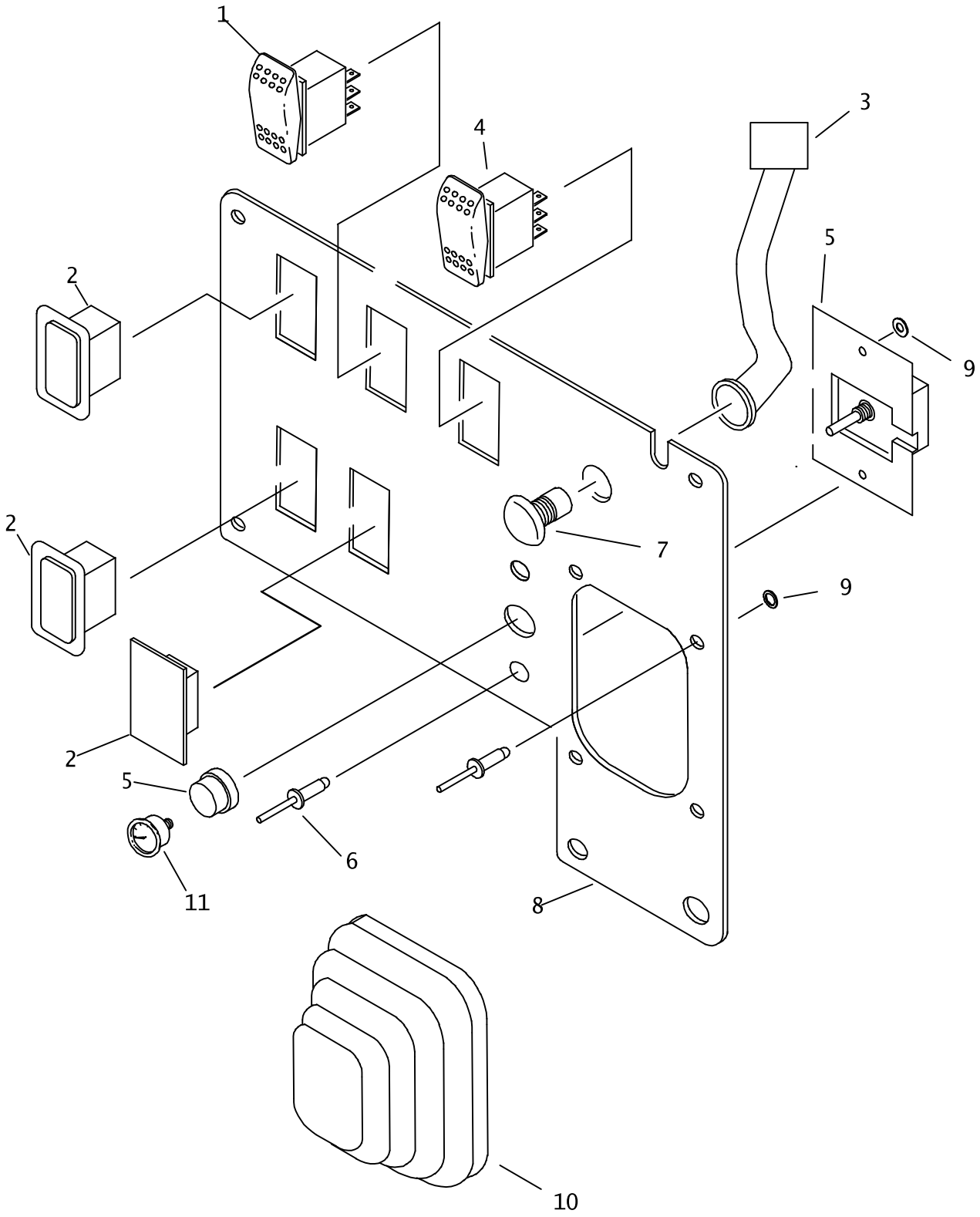

OPERATORS STATION GAUGES

REF NO.	PART NUMBER	QTY	DESCRIPTION	REMARKS
1.	217-764	1	ROCKER SWITCH (SPDT)	
2.	362-823	3	COVER	
3.	215-754	1	MC INSULATOR (2-TERMINAL)	
4.	217-762	1	ROCKER SWITCH (SPDT)	
5.	217-940	1	FLUID FLOW POTENTIOMETER	
	110-641	1	KNOB (1/8", BLK)	
6.	110-560	6	POP RIVET (3/16" X 1/2", ALUM)	
7.	214-943	1	BUTTON SWITCH (SPST)	
8.	346-725	-	COVER PLATE	
9.	106-205	4	WASHER (.191")	
10.	353-243	1	SHIFTER BOOT (RUBBER)	
11.	274-940	1	INDICATOR	

FOOTNOTES

NOTE:

D

808-321

CONSOLE GAUGES

JT920 / JT920C / JT921

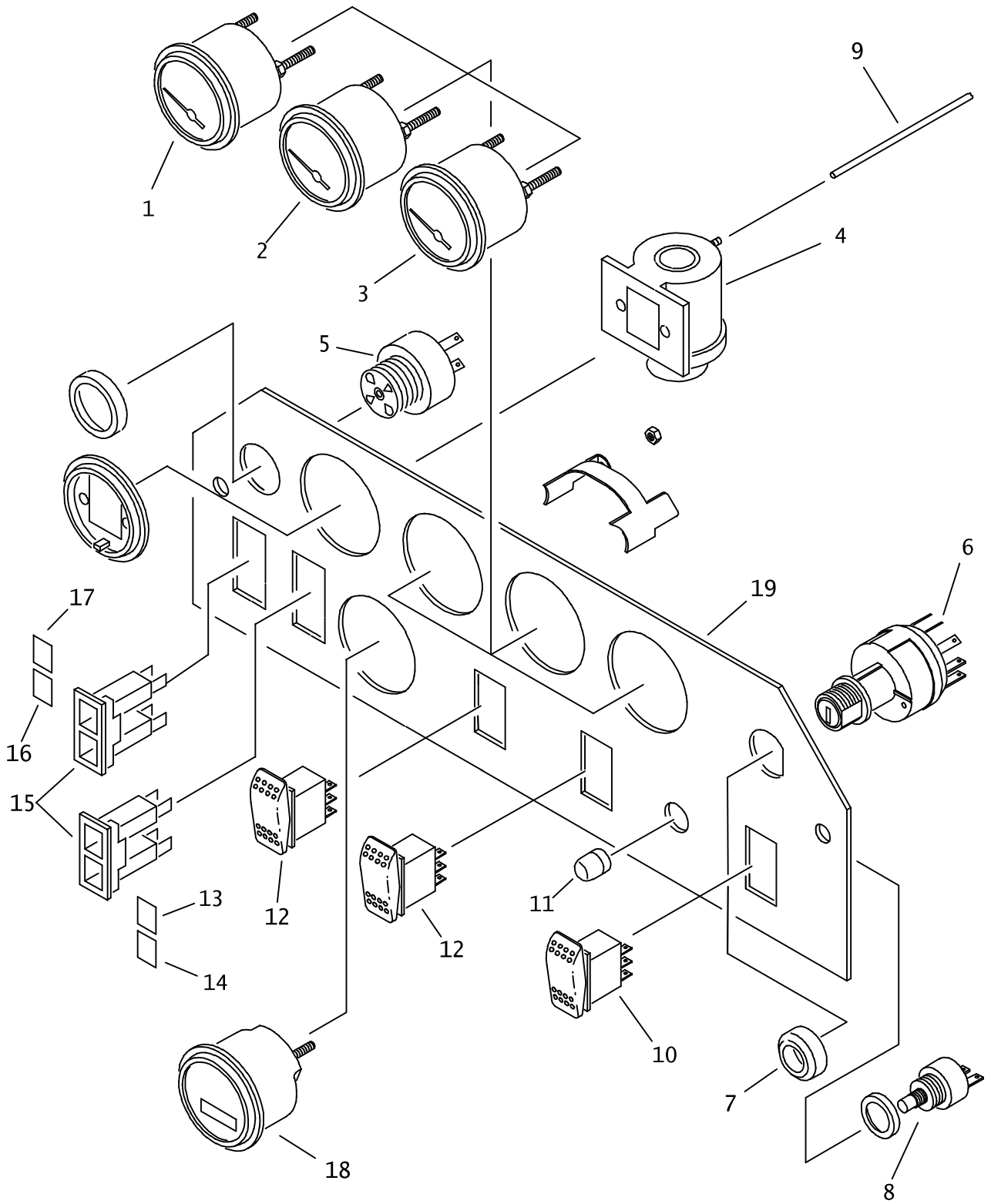

CONSOLE GAUGES

JT920 / JT920C / JT921

REF NO.	PART NUMBER	QTY	DESCRIPTION	REMARKS
1.	215-133	1	FUEL GAUGE	
2.	215-129	1	VOLT METER	
3.	217-512	1	WATER TEMPERATURE GAUGE	
4.	215-150	1	RESTRICTION INDICATOR (20", H2O)	USE WITH LISTER-PETTER ENGINE
	258-067	1	RESTRICTION INDICATOR (25", H2O)	USE WITH CATERPILLAR ENGINE
5.	306-603	1	AUDIO ALARM	
6.	214-852	1	IGNITION SWITCH	INCL. KEYS & NUT
	214-961	1	KEYS (PAIR)	
7.	214-962	1	SWITCH MOUNTING NUT	
8.	306-607	1	HORN BUTTON	
9.	116-192	-	BULK HOSE (7/64", SOLD PER 1")	USE @ 55"
10.	217-789	1	ROCKER SWITCH	
11.	306-608	1	BUTTON COVER	
12.	217-762	1	ROCKER SWITCH (SPDT)	
13.	217-036	1	INSERT (YEL) HYD OIL PSI	
14.	217-028	1	INSERT (BLK) BLANK	
15.	217-020	2	PILOT LIGHT	
	217-046	1	BULB (12V DC)	
16.	217-027	1	INSERT (RED) HYD OIL HI TEMP	
17.	217-021	1	INSERT (RED) ENG OIL PSI	
18.	215-128	1	HOUR METER	
19.	320-619	-	INSTRUMENT PANEL	

NOT SHOWN:

FOOTNOTES:

NOTE:

NOTES:

HYDRAULICS

HYDRAULIC SCHEMATIC W/AUTOBORE SHUTOFF

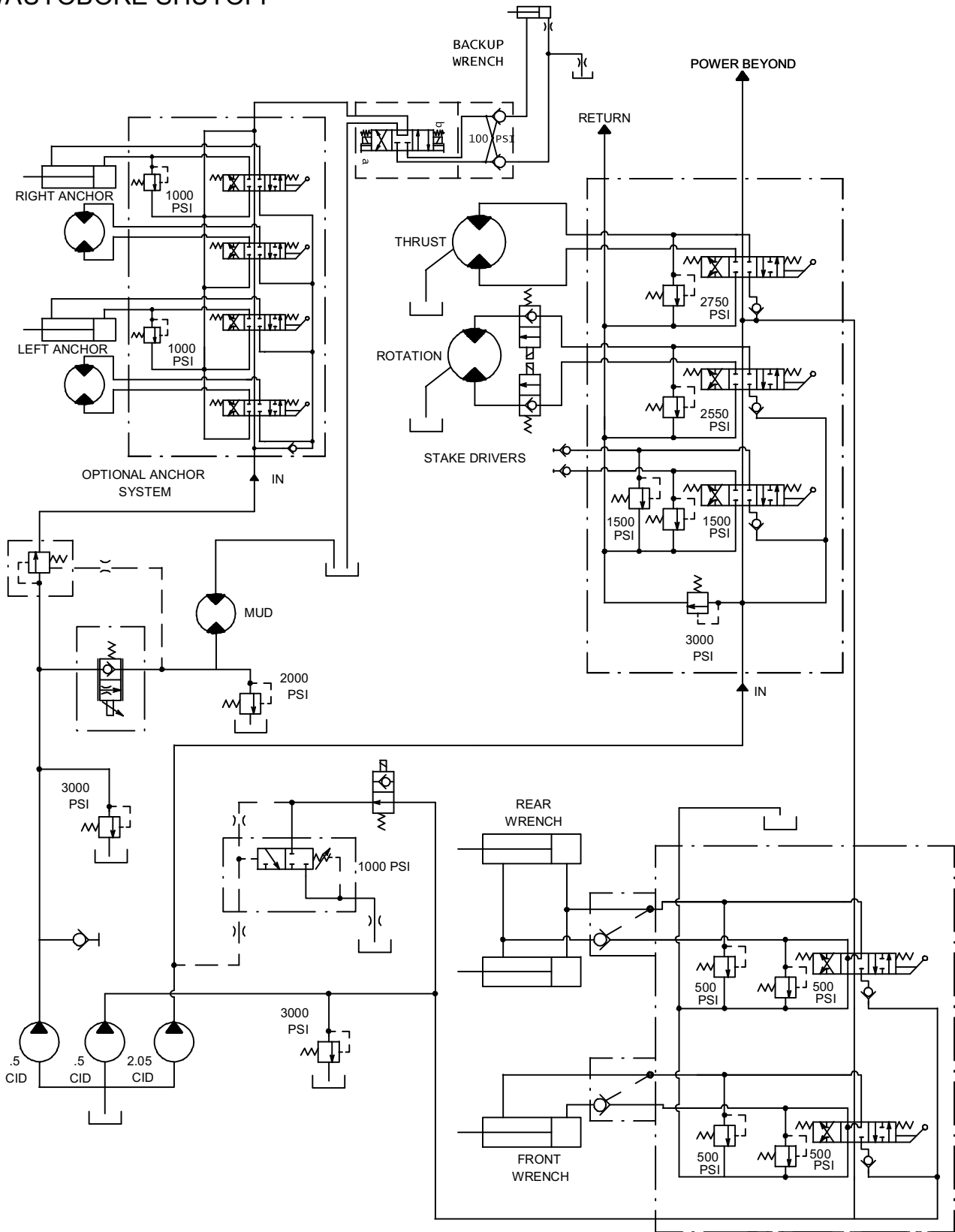

HYDRAULIC SCHEMATIC W/AUTOBORE SHUTOFF

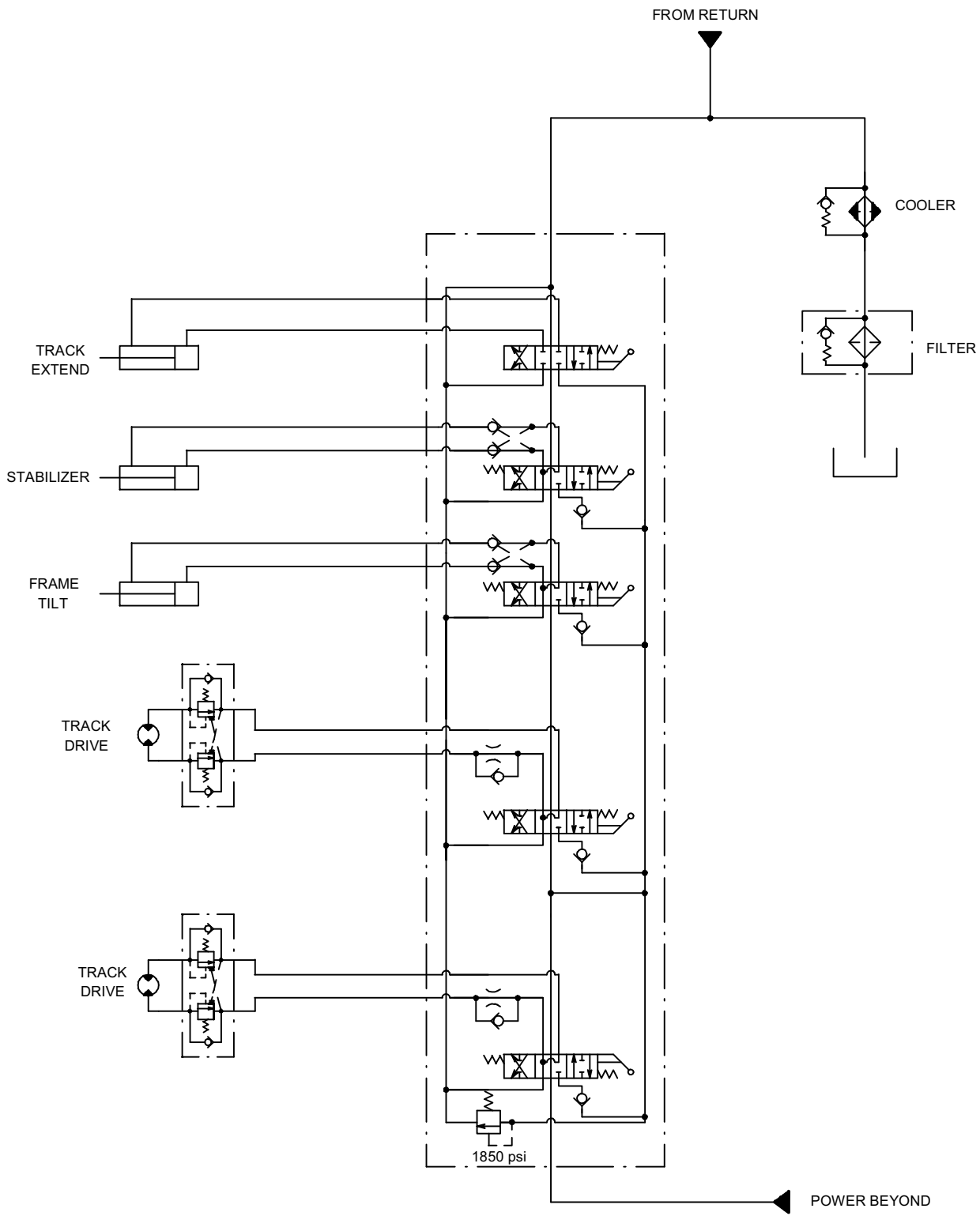

HYDRAULIC DIAGRAM

AUTOBORE SHUTOFF

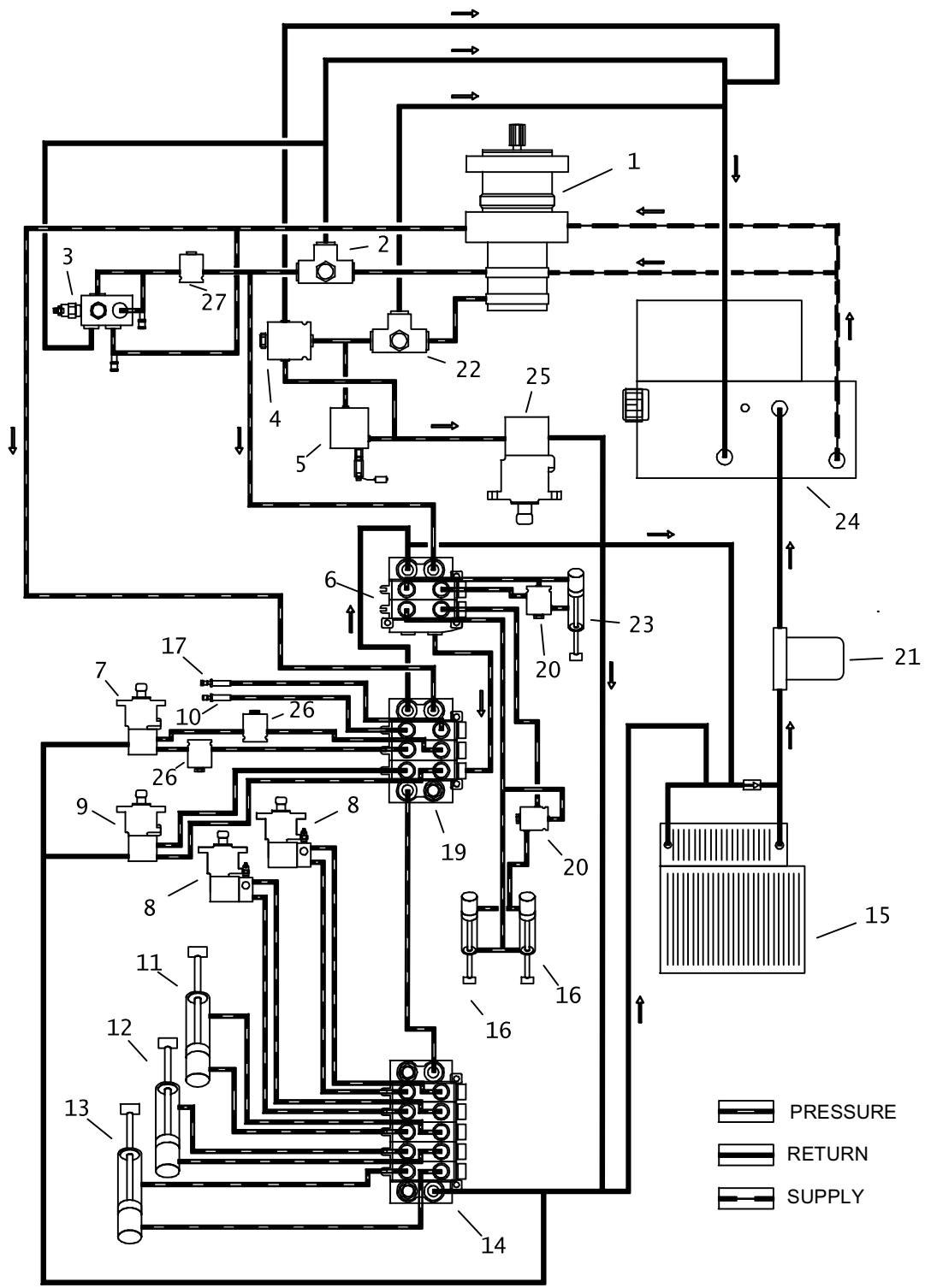

HYDRAULIC DIAGRAM

AUTOBORE SHUTOFF

REF NO.	PART NUMBER	QTY	DESCRIPTION	REMARKS
1.	158-420	-	HYD PUMP	
2.	158-601	-	HYD RELIEF VALVE (3000 PSI)	
3.	158-814	-	CONTROL VALVE	
4.	158-687	-	PRIORITY VALVE	
5.	157-784	-	HYD FLOW VALVE	
6.	516-027	-	HYD CONTROL VALVE (2-SPOOL)	
7.	158-881	-	HYD MOTOR	
8.	158-826	-	HYD MOTOR (GEROLER)	
9.	158-908	-	HYD MOTOR (THRUST, 8600#)	
	190-728	-	SEAL REPAIR KIT	
10.	159-029	-	QDC BODY (08-08SF)	
11.	151-054	-	CYL (3.0" X 1.50" X 4.00")	
12.	151-117	-	CYL (3.0" X 1.50" X 20.00")	
13.	151-076	-	CYL (2.0" X 1.00" X 10.00")	
14.	158-937	-	HYD CONTROL VALVE (1-SPOOL)	
15.	360-383	-	OIL COOLER & RADIATOR ASS'Y	
	306-829	-	OIL COOLER	
	306-830	-	RADIATOR	
16.	150-724	-	CYL, 1" BORE X 2" STROKE THRD	
17.	159-030	-	QDC ADAPTER (08-08SF)	
18.	158-815	-	FLOW DIVIDER	
19.	516-028	-	HYD CONTROL VALVE (1-SPOOL)	
20.	155-259	-	CHECK VALVE	
21.	159-081	-	HYD OIL FILTER (20SF-20SF)	
22.	155-622	-	HYD RELIEF VALVE (2000 PSI)	
23.	151-125	-	CYL (1.5" X 0.44" X 2.50")	
24.	350-503	-	MOBILING STATION	
25.	158-403	-	GEAR MOTOR (3.0 CUI\ REV)	
26.	149-495	-	HYD SOLENOID VALVE	
	155-724	-	O-RING (217 D70)	
	217-941	1	SOLENOID COIL	
	500-620	1	SEAL REPAIR KIT	
27.	158-569	-	SOLENOID DIVERSION VALVE	

FOOTNOTES

NOTE:

D

806-591

HYDRAULIC DIAGRAM

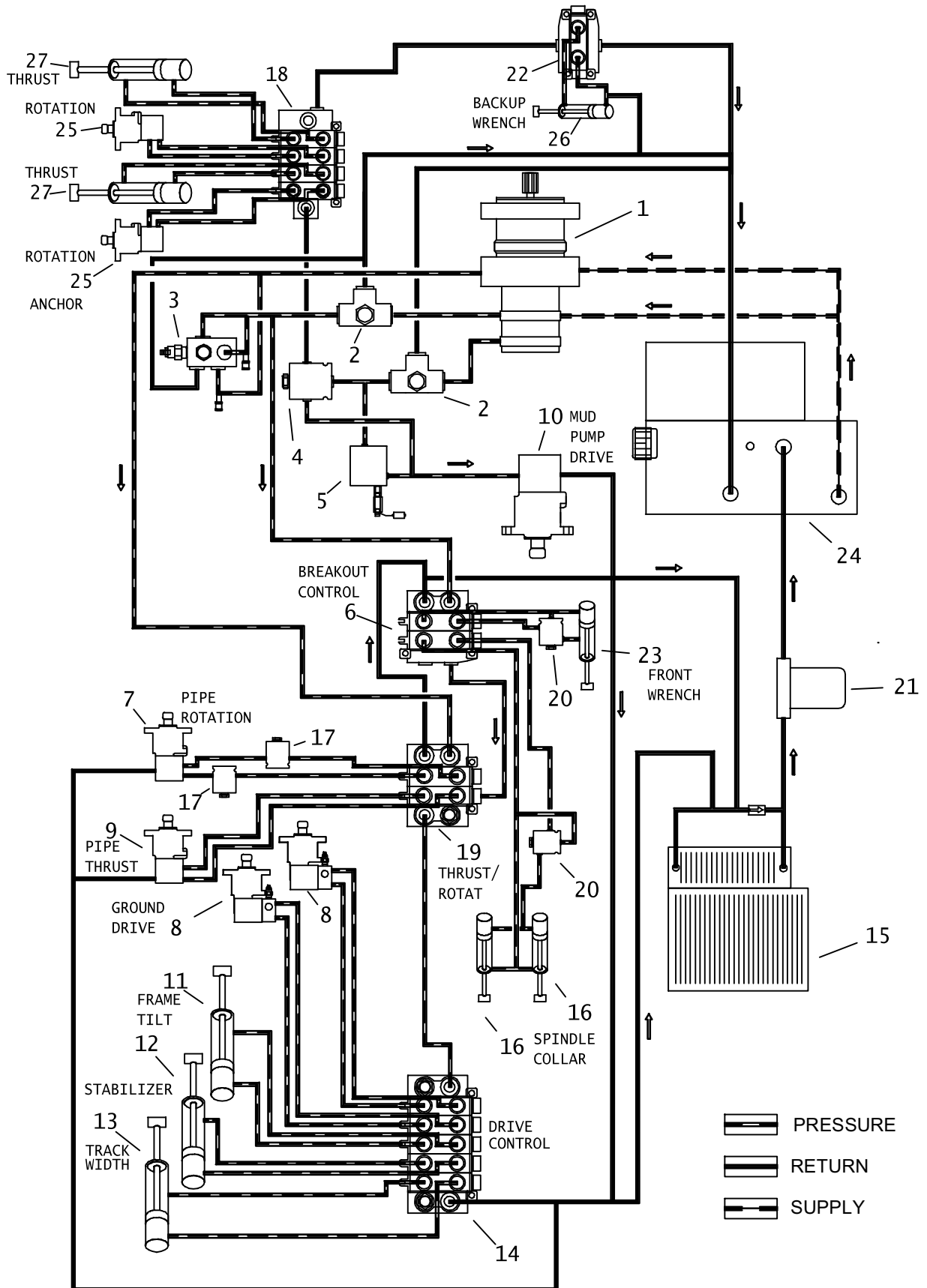

HYDRAULIC DIAGRAM

REF NO.	PART NUMBER	QTY	DESCRIPTION	REMARKS
1.	158-420	-	HYD PUMP	
2.	158-601	-	HYD RELIEF VALVE (300PSI)	
3.	158-814	-	CONTROL VALVE	
	500-906		CONTROL VALVE CARTRIDGE	
	190-643		SEAL REPAIR KIT	
4.	158-687	-	PRIORITY VALVE	
5.	157-784	-	HYD FLOW VALVE	
6.	516-027	-	HYD CONTROL VALVE (2-SPOOL)	
7.	158-881	-	HYD MOTOR	
8.	158-826	-	HYD MOTOR (GEROLER)	
9.	158-908	-	HYD MOTOR (THRUST)	
10.	158-469	-	GEAR MOTOR (3.0 CUI/REV)	
11.	151-054	-	CYL (3.0" X 1.50" X 4.00")	
12.	151-147	-	CYL (3" X 1.5" X 20")32"	
13.	151-076	-	CYL (2.0" X 1.00" X 10.00")	
14.	158-937	-	HYD CONTROL VALVE (_-SPOOL)	
15.	360-383	-	OIL COOLER & RADIATOR ASS'Y	
	306-829	-	OIL COOLER	
	306-830	-	RADIATOR	
16.	150-724	-	CYL, 1" BORE X 2." STROKE THRD	
17.	149-495	-	HYD SOLENOID VALVE	
	217-941	1	SOLENOID COIL	
	500-620	1	SEAL REPAIR KIT	
18.	158-944	-	HYD CONTROL VALVE	
19.	516-124	-	HYD CONTROL VALVE 2 SECTION	
20.	155-259	-	CHECK VALVE	
21.	159-081	-	HYD OIL FILTER (20SF-20SF)	
22.	516-098	-	SOLENOID VALVE (SINGLE)	
23.	150-725	-	CYL, 1" BORE X 2.5" STROKE THRD	
24.	350-503	-	MOBILING STATION	
25.	158-700	-	HYD MOTOR	
26.	150-723	-	CYL, 1" X 2" STROKE	
27.	151-096	-	CYL (2" X 1" X 24")	

FOOTNOTES

NOTE:

P

805-128

HYDRAULIC DIAGRAM

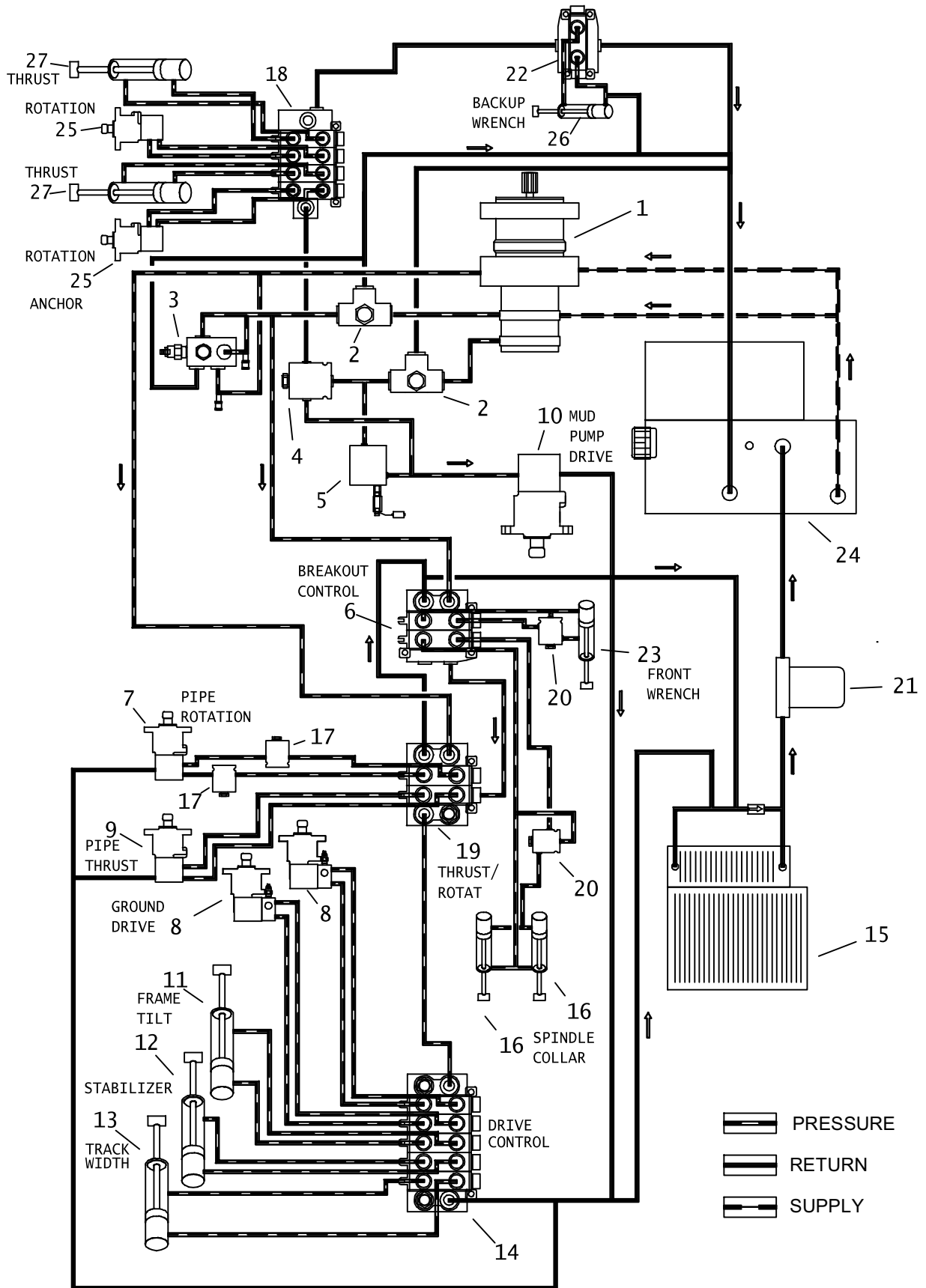

HYDRAULIC DIAGRAM

REF NO.	PART NUMBER	QTY	DESCRIPTION	REMARKS
1.	158-420	-	HYD PUMP	
2.	158-601	-	HYD RELIEF VALVE (300PSI)	
3.	158-814	-	CONTROL VALVE	
	500-906		CONTROL VALVE CARTRIDGE	
	190-643		SEAL REPAIR KIT	
4.	158-687	-	PRIORITY VALVE	
5.	157-784	-	HYD FLOW VALVE	
6.	516-027	-	HYD CONTROL VALVE (2-SPOOL)	
7.	158-881	-	HYD MOTOR	
8.	158-826	-	HYD MOTOR (GEROLER)	
9.	158-908	-	HYD MOTOR (THRUST)	
10.	158-469	-	GEAR MOTOR (3.0 CUI/REV)	
11.	151-054	-	CYL (3.0" X 1.50" X 4.00")	
12.	151-147	-	CYL (3" X 1.5" X 20")32"	
13.	151-076	-	CYL (2.0" X 1.00" X 10.00")	
14.	158-937	-	HYD CONTROL VALVE (_-SPOOL)	
15.	360-383	-	OIL COOLER & RADIATOR ASS'Y	
	306-829	-	OIL COOLER	
	306-830	-	RADIATOR	
16.	150-724	-	CYL, 1" BORE X 2." STROKE THRD	
17.	149-495	-	HYD SOLENOID VALVE	
	217-941	1	SOLENOID COIL	
	500-620	1	SEAL REPAIR KIT	
18.	158-944	-	HYD CONTROL VALVE	
19.	516-124	-	HYD CONTROL VALVE 2 SECTION	
20.	155-259	-	CHECK VALVE	
21.	159-081	-	HYD OIL FILTER (20SF-20SF)	
22.	516-098	-	SOLENOID VALVE (SINGLE)	
23.	150-725	-	CYL, 1" BORE X 2.5" STROKE THRD	
24.	350-503	-	MOBILING STATION	
25.	158-700	-	HYD MOTOR	
26.	150-723	-	CYL, 1" X 2" STROKE	
27.	151-096	-	CYL (2" X 1" X 24")	

FOOTNOTES

NOTE:

HYDRAULIC RESERVOIR

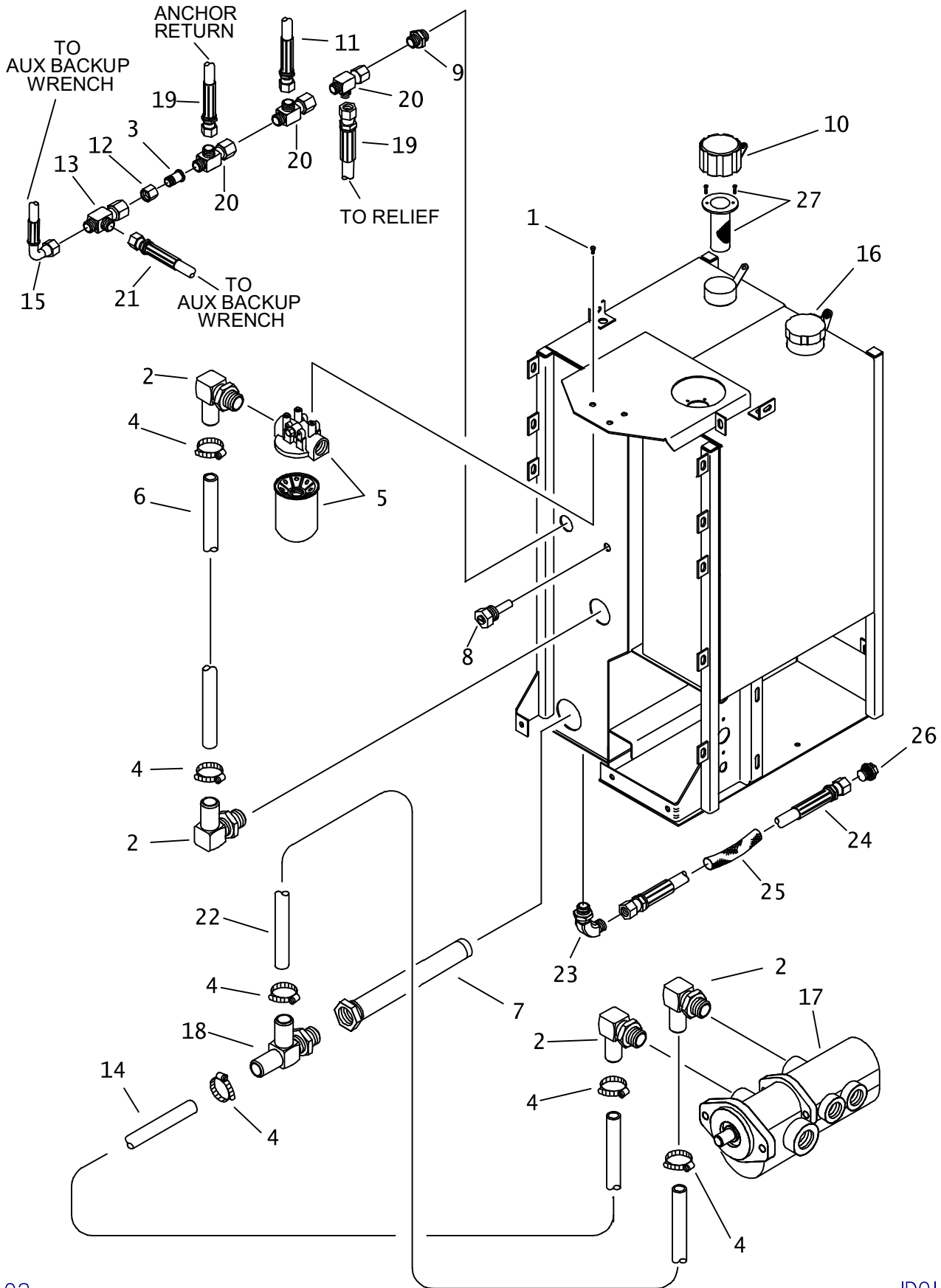

HYDRAULIC RESERVOIR

REF NO.	PART NUMBER	QTY	DESCRIPTION	REMARKS
1.	105-825	3	FLG LK BOLT (3/8-NC X 3/4")	
2.	155-168	4	S/O CPLR (20S-20H90)	
3.	154-248	1	REDUCER STEM (040)	
4.	110-133	6	WORM CLAMP (1-1/16" TO 1-15/16")	
5.	159-081	-	HYD OIL FILTER (20SF-20SF)	
	217-765	-	INDICATOR SWITCH	
	159-079	-	FILTER ELEMENT (1-1/2-UNF)	USE 19.5"
6.	116-587	AR	BULK HOSE (1.250")	
7.	110-336	1	STRAINER	ENDS WITH S/N _____
8.	215-148	-	TEMPERATURE SWITCH	BEGINS WITH S/N _____
	214-819	1	TEMPERATURE SWITCH	
9.	154-233	1	CONNECTOR (08S-080)	ENDS WITH S/N, SEE FOOTNOTE 1
10.	110-996	1	FILLER BREATHER (2-1/8")	ENDS WITH S/N
	165-626	1	GASKET	BEGINS WITH S/N 2V0893 JT920L
	153-766	1	LOCKING CAP (VENTED)	USE WITH JT920 ONLY
11.	154-942	1	HOSE (080FX90S-13"-3000)	
12.	154-272	1	REDUCER NUT (080F)	
13.	154-265	1	UNION RUN TEE (040FX-040-040)	USE 1@ 12"
14.	116-587	AR	BULK HOSE (1.250", SOLD PER 1')	
15.	515-179	1	HOSE (040FX90-11"-3000)	
16.	350-503	-	MOBILING STATION	
17.	158-420	-	HYDRAULIC PUMP	
18.	155-279	1	S/O RUN TEE (20S-20H-20H)	
19.	154-828	2	HOSE (080FX-17"-3000)	
20.	154-266	3	UNION RUN TEE (080FX-080-080)	
21.	515-041	1	HOSE (040FX90-20"-3000)	USE 1@ 8.25"
22.	116-587	AR	BULK HOSE (1.250")	
23.	154-342	1	CONNECTOR (06S-06090)	
24.	154-722	1	HOSE (060FX-32"-3000)	
25.	117-676	1	ABRASUJIB SLEEVE (1.00" X 30")	
26.	154-330	1	PLUG (060)	
27.	153-900	1	STRAINER	
	105-189	2	SCREW (#6-32 X 1/2")	

NOT SHOWN:

FOOTNOTES:

REFER TO O-RING CHART (800-301) IN BACK OF THE BOOK FOR REPLACEMENT OF O-RINGS.

NOTE:

OIL COOLER HYDRAULICS

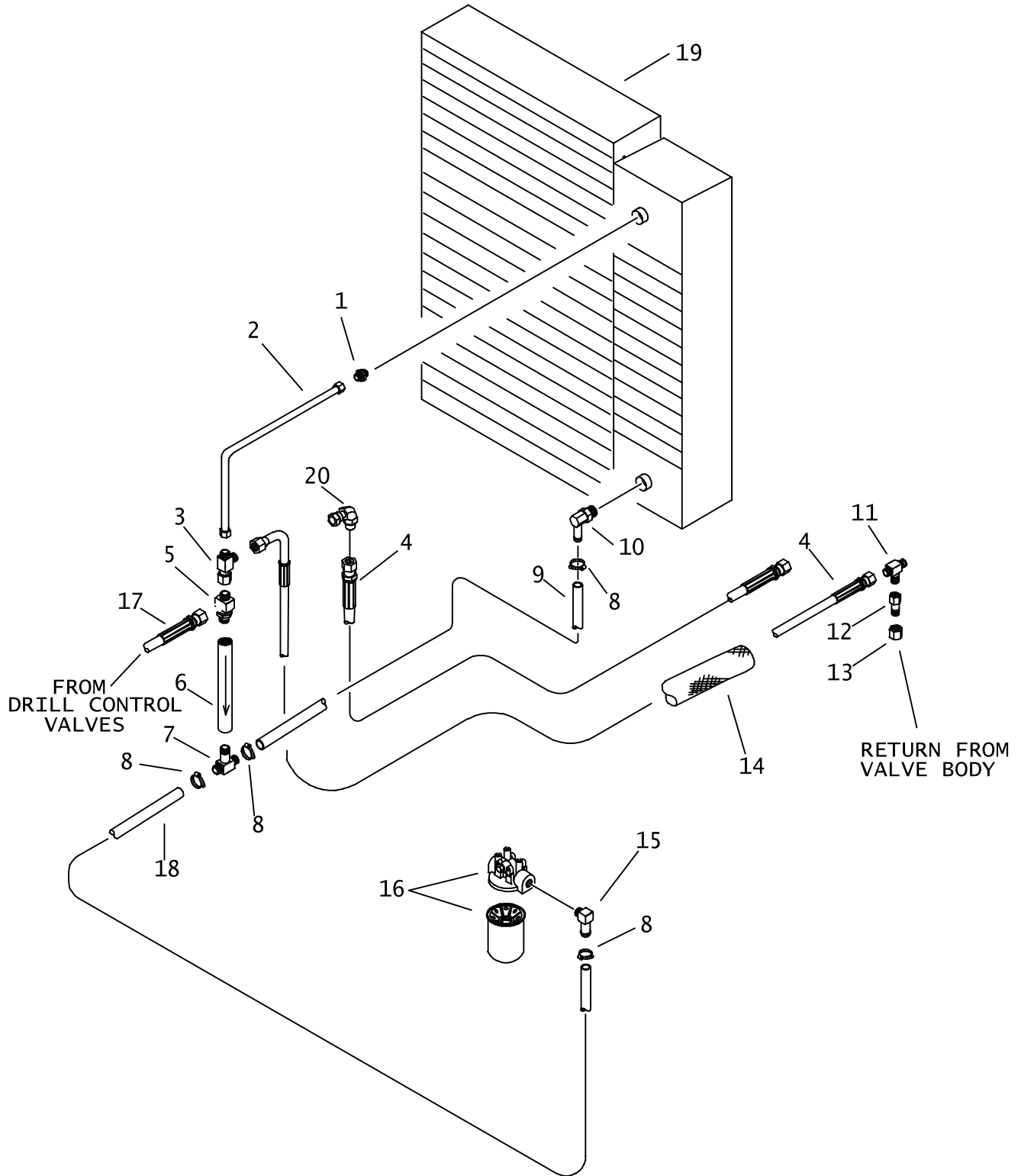

OIL COOLER HYDRAULICS

REF NO.	PART NUMBER	QTY	DESCRIPTION	REMARKS
1.	154-269	1	CONNECTOR (12S-120)	
2.	156-563	1	HYD LINE (-12)	
3.	154-368	1	UNION RUN TEE (120FX-120-120)	
4.	515-242	1	HOSE (120FX90-95"-3000)	WITH WATER TANK. USE WITH JT920 & JT921
	515-230	1	HOSE (120FX-54"-4000)	WITHOUT WATER TANK. USE WITH JT921S
5.	154-292	1	RUN TEE (12S-120-120)	
6.	158-576	1	CHECK VALVE (12SF-12SF)	ENDS WITH S/N 2N1740
	155-245	-	FLOW CHECK VALVE (12SF-12SF)	BEGINS WITH S/N 2N1741
7.	514-043	1	S/O BR TEE (12S-20H-20H)	
8.	110-133	4	WORM CLAMP (1-1/6" - 1-15/16")	
9.	116-587	AR	BULK HOSE (1.250", SOLD PER 1")	USE 17"
10.	514-027	1	S/O COUPLER (12S-20H90)	
11.	154-368	1	UNION RUN TEE (120FX-120-120)	
12.	154-249	1	REDUCER STEM (080)	
13.	154-271	1	REDUCER NUT (120F)	
14.	115-924	1	ABRASION SLEEVE (1.59" X 88")	
	115-903	1	ABRASION SLEEVE (1.59" X 50")	
15.	155-168	1	SLIP-ON COUPLER (20S-20H90)	
16.	159-081	1	HYDRAULIC OIL FILTER (20SF-20SF)	WITH WATER TANK
	159-079	1	FILTER ELEMENT (1-1/2-UNF)	WITHOUT WATER TANK
17.	515-218	1	HOSE 120FX90-80"-3000)	
18.	116-587	AR	BULK HOSE ((1.250", SOLD PER 1")	USE 65"
19.	360-383	-	RADIATOR/OIL COOLER	
	306-829	-	OIL COOLER	
	306-830	-	RADIATOR	
20.	154-457	1	UNION (120-120FX90)	WITHOUT WATER TANK. USE WITH JT921S

FOOTNOTES

NOTE:

REFER TO O-RING CHART (800-30I) IN BACK OF THE BOOK FOR REPLACEMENT OF O-RINGS.

L

804-026

OIL COOLER HYDRAULICS (CATERPILLAR DIESEL)

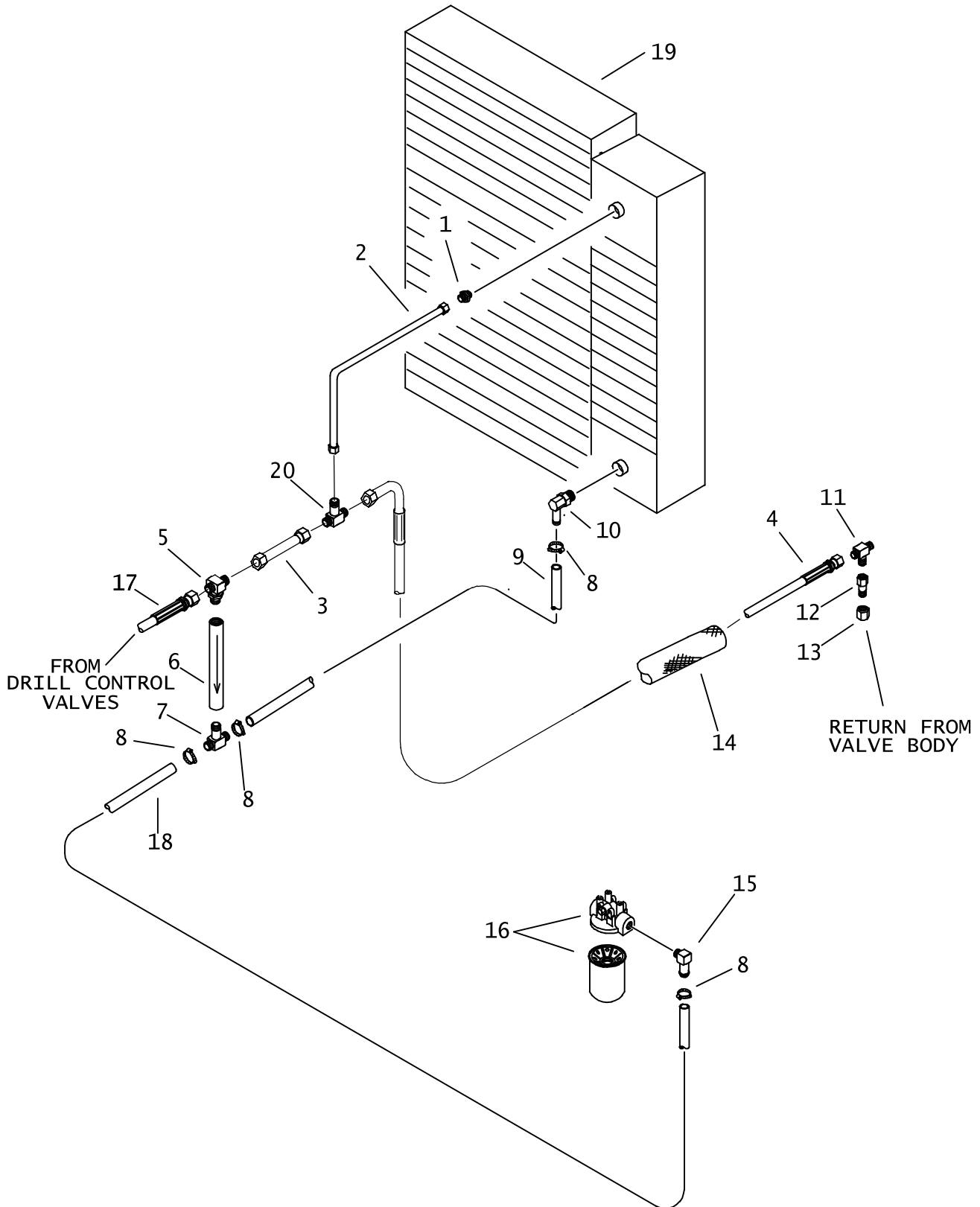

OIL COOLER HYDRAULICS (CATERPILLAR DIESEL)

REF NO.	PART NUMBER	QTY	DESCRIPTION	REMARKS
1.	154-269	1	CONNECTOR (12S-120)	
2.	159-639	1	HYD LINE (-12)	
3.	159-640	1	HYD LINE (-12)	
4.	515-242	1	HOSE (120FX90-95"-3000)	WITH WATER TANK
	515-001	1	HOSE 120FX-90-60"-3000)	WITHOUT WATER TANK
5.	154-294	1	BRANCH TEE (12S-120-120)	
6.	155-245	1	FLOW CHECK VALVE (12SF-12SF)	
7.	514-043	1	S/O BR TEE (12S-20H-20H)	
8.	110-133	4	WORM CLAMP (1-1/6" - 1-15/16")	
9.	116-587	AR	BULK HOSE (1.250", SOLD PER 1")	USE 19"
10.	514-027	1	S/O COUPLER (12S-20H90)	
11.	154-368	1	UNION RUN TEE (120FX-120-120)	
12.	154-249	1	REDUCER STEM (080)	
13.	154-271	1	REDUCER NUT (120F)	
14.	115-924	1	ABRASION SLEEVE (1.59" X 88")	
	115-903	1	ABRASION SLEEVE (1.59" X 50")	
15.	155-168	1	SLIP-ON COUPLER (20S-20H90)	
16.	159-081	1	HYDRAULIC OIL FILTER (20SF-20SF)	WITH WATER TANK
	159-079	1	FILTER ELEMENT (1-1/2-UNF)	WITHOUT WATER TANK
17.	515-218	1	HOSE 120FX90-80"-3000)	
18.	116-587	AR	BULK HOSE ((1.250", SOLD PER 1")	USE 61.5"
19.	194-463	-	RADIATOR/HOC	
20.	154-455	1	TEE (120)	

NOT SHOWN:

FOOTNOTES:

REFER TO O-RING CHART (800-301) IN BACK OF THE BOOK FOR REPLACEMENT OF O-RINGS.

NOTE:

DRIVE CONTROL SUPPLY HYD.

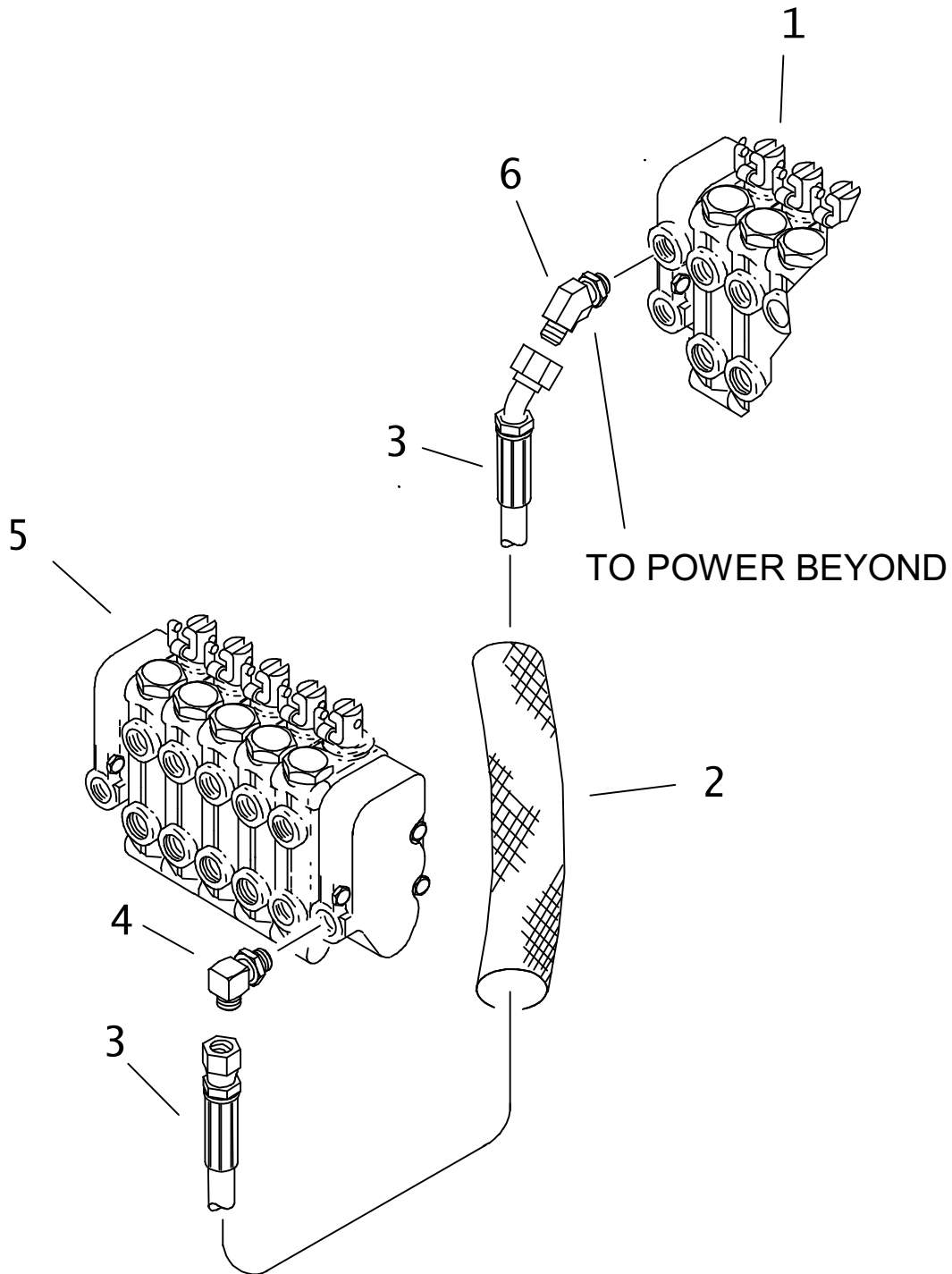

DRIVE CONTROL SUPPLY HYD.

REF NO.	PART NUMBER	QTY	DESCRIPTION	REMARKS
1.	516-124	-	HYD CONTROL VALVE 2 SECTION	BEGINS WITH S/N N2T1062
2.	115-961	1	ABRASION SLEEVE (2.07" X 196")	WITH WATER TANK. USE WITH JT920 & JT921
	117-995	1	ABRASION SLEEVE (2.07" X 156")	WITHOUT WATER TANK. USE WITH JT921S
3.	515-513	1	HOSE (120FX45-195"-3000)	WITH WATER TANK. USE WITH JT920 & JT921
	515-514	1	HOSE (120FX45-160"-3000)	WITHOUT WATER TANK. USE WITH JT921S
4.	154-273	1	CONNECTOR (10S-12090)	WITH WATER TANK. USE WITH JT920 & JT921
5.	158-937	-	HYD CONTROL VALVE (5-SPOOL)	WITHOUT WATER TANK. USE WITH JT921S
	499-333	-	VALVE SECTION (GROUND DRIVE)	
6.	154-251	1	CONNECTOR (12S-12045)	

FOOTNOTES

NOTE:

REFER TO O-RING CHART (800-301) IN BACK OF BOOK FOR REPLACEMENT OF O-RINGS.

GROUND DRIVE HYDRAULICS

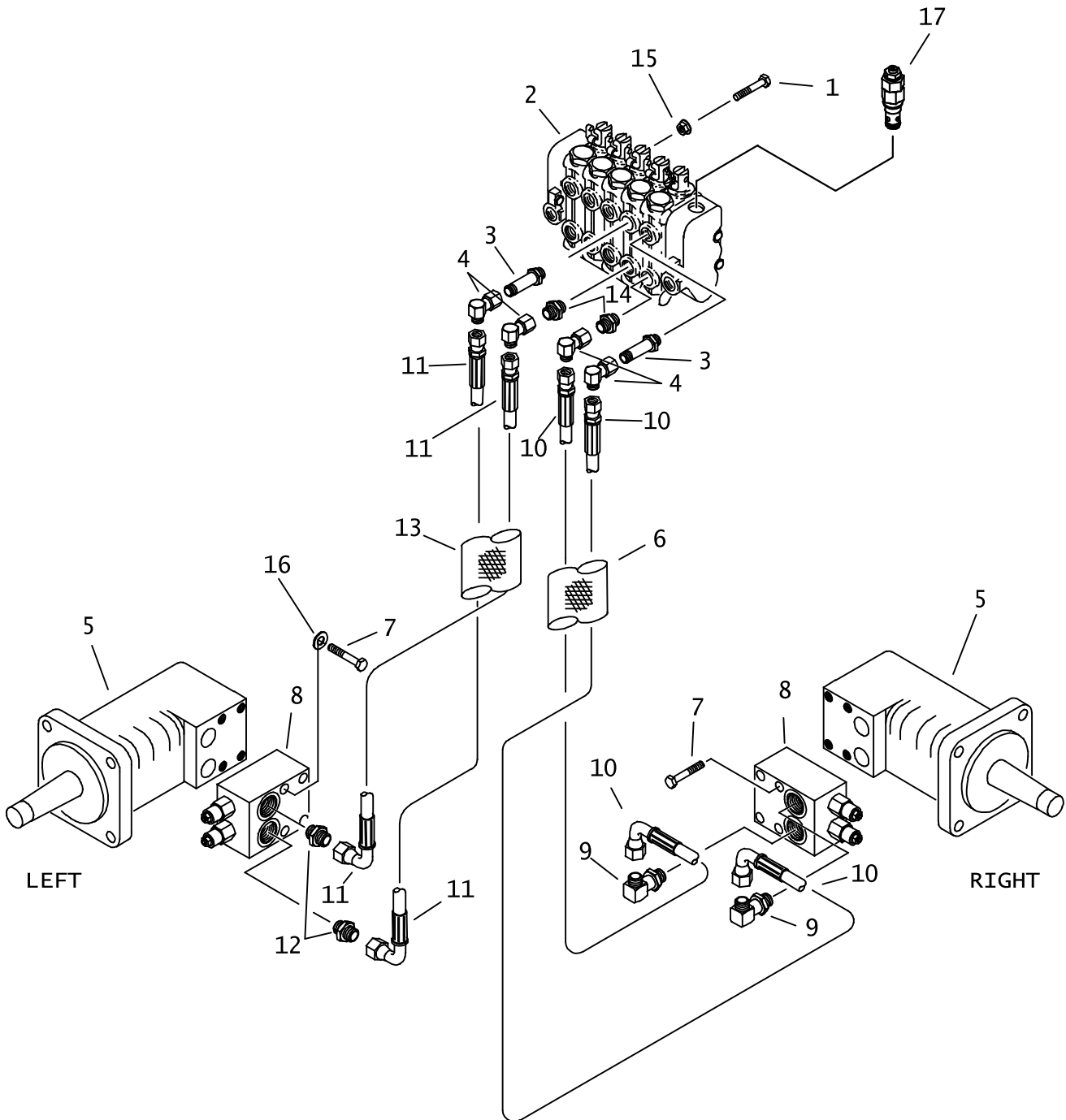

GROUND DRIVE HYDRAULICS

REF NO.	PART NUMBER	QTY	DESCRIPTION	REMARKS
1.	105-827	3	FLG LK BOLT (3/8-NC X 1-1/4")	
2.	158-937	-	HYD CONTROL VALVE (_-SPOOL)	
	500-562		SPOOL END CAP	SEE FOOTNOTE 1
	500-563		SPRING CENTERING KIT	SEE FOOTNOTE 1
	500-558		VALVE SECTION (#V12W-1FBCAS)	SEE FOOTNOTE 1
	500-559		VALVE SECTION (#V12W-1FBCJLEE)	SEE FOOTNOTE 1
	499-333		VALVE SECTION V12W-1FBCJS(GRNDDRV)	SEE FOOTNOTE 1
	191-159		CONTROL LEVER BRACKET	SEE FOOTNOTE 1
	500-512		LEVER PIVOT (CLEVIS)	SEE FOOTNOTE 1
	500-877		SPOOL CLEVIS (YOKE)	SEE FOOTNOTE 1
3.	154-438	2	CONNECTOR (08S-080, LG)	
4.	154-256	4	UNION (080-080FX90)	
5.	158-826	-	HYD MOTOR (GEROLER)	
	107-034		CASTLE NUT (1-20 NEF)	
	166-846		WOODRUFF KEY (5/16" X 1")	
	499-433		COUPLING SHAFT	
	499-434		OUTER SHAFT BEARING	
	157-701		SHAFT SEAL	
	500-510		SEAL REPAIR KIT	
	500-1576		ASSEMBLY BOLT	
	500-1577		SERVICE HOUSING	
6.	115-963	1	ABRASION SLEEVE (1.59" X 75")	WITH WATER TANK
	115-903	1	ABRASION SLEEVE (1.59" X 50")	WITHOUT WATER TANK
7.	105-178	8	BOLT (5/16-NC X 2-1/2",GD8)	
8.	159-302	2	COUNTERBALANCE MANIFOLD	
	500-819	4	COUNTERBALANCE CARTRIDGE KIT	
	157-096	2	O-RING (017 D70)	
9.	154-322	2	CONNECTOR (080-10S90)	
10.	515-241	2	HOSE (080FX90L-82"-3000)	WITH WATER TANK
	515-192	2	HOSE (080FX90L-54"-3000)	WITHOUT WATER TANK
11.	515-243	2	HOSE(080FX90-66"-3000)	WITH WATER TANK
	515-191	2	HOSE (080FX90S-54"-3000)	WITHOUT WATER TANK
12.	154-279	2	CONNECTOR (080-10S)	
13.	115-938	1	ABRASION SLEEVE (1.59" X 66")	WITH WATER TANK
	115-903	1	ABRASION SLEEVE (1.59" X 50")	WITHOUT WATER TANK
14.	154-233	2	CONNECTOR (08S-080)	
15.	105-845	3	FLG LOCKNUT (3/8-NC)	
16.	105-095	8	WASHER (1/4")	
17.	150-1064	1	PILOT OPERATED RELIEF(ADJ.1850 PSI)	BEGINS WITH S/N: 2zI825

FOOTNOTES:

- I. THESE PART ARE RELATIVE TO I58-801 AND I58-937 VALVES.

NOTE:

REFER TO O-RING CHART (800-301) IN BACK OF THE BOOK FOR REPLACEMENT OF O-RINGS.

DRIVE CONTROL VALVE & LEVERS

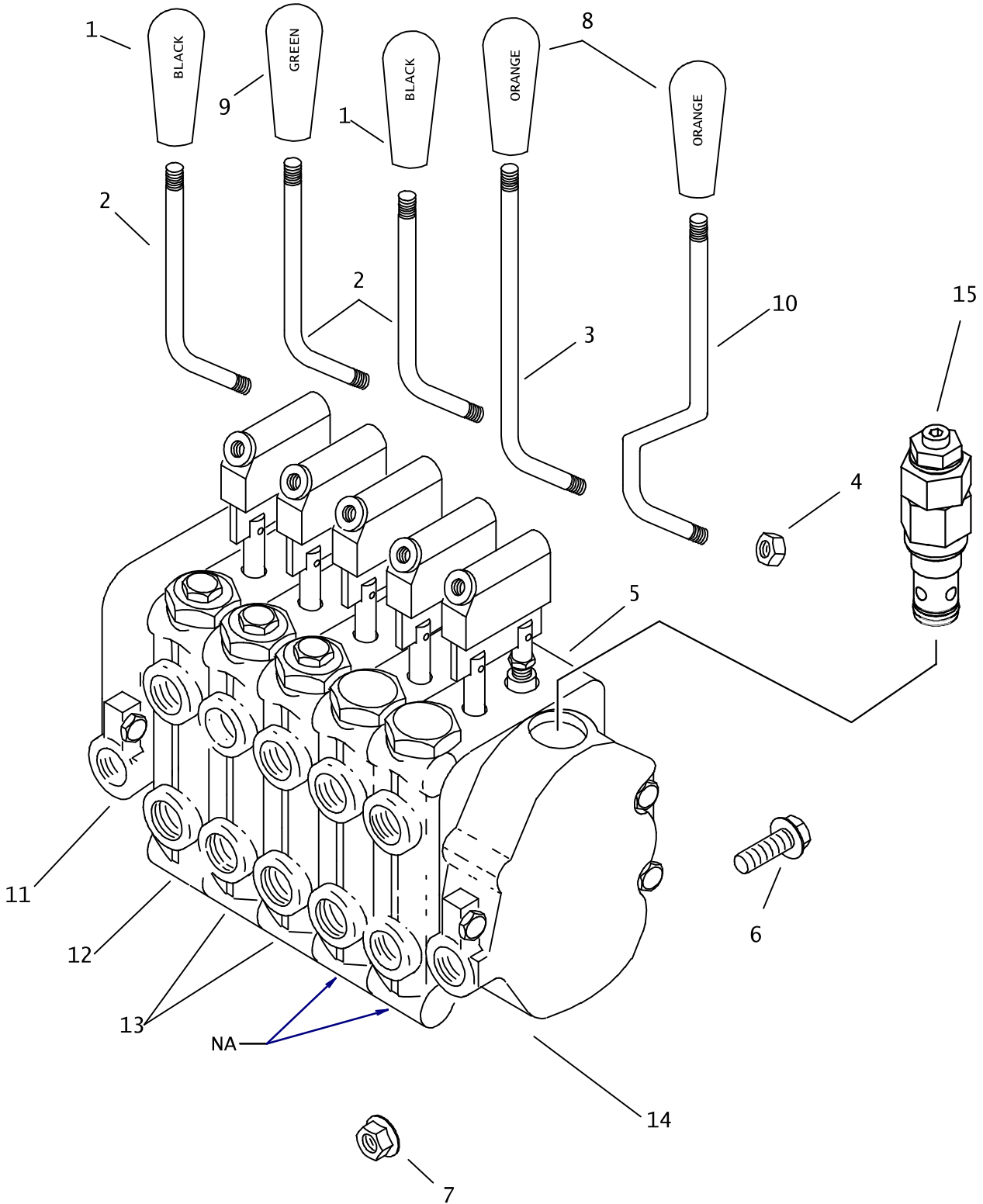

DRIVE CONTROL VALVE & LEVERS

REF NO.	PART NUMBER	QTY	DESCRIPTION	REMARKS
1.	110-531	2	HANDLE (1/2-NC, BLACK)	
2.	353-140	3	CONTROL LEVER	USE 242 LOCTITE
3.	353-141	1	CONTROL LEVER	USE 242 LOCTITE
4.	105-044	5	JAM NUT (1/2-NC)	
5.	158-937	1	HYD CONTROL VALVE (_-SPOOL)	
6.	105-827	3	FLG LK BOLT (3/8-NC X 1-1/4")	BEGIN WITH S/N 2N2402
7.	105-845	3	FLG LOCKNUT (3/8-NC)	
8.	110-465	2	KNOB (1/2-NC, ORANGE)	
9.	110-530	1	HANDLE (1/2-NC, GREEN)	
10.	353-311	1	CONTROL LEVER	USE 242 LOCTITE
11.	500-565	-	OUTLET COVER.	
12.	500-559	-	VALVE SECTION (#V12W-1FBCAS)	
13.	500-558	-	VALVE SECTION (#V12W-1FBCJLEE)	
14.	500-556	-	INLET COVER	
15.	150-1064	1	PILOT OPERATED RELIEF (ADI, 1850 PSI)	BEGINS WITH S/N 2zi825

NOT SHOWN:

FOOTNOTES:

NOTE:

FRAME TILT

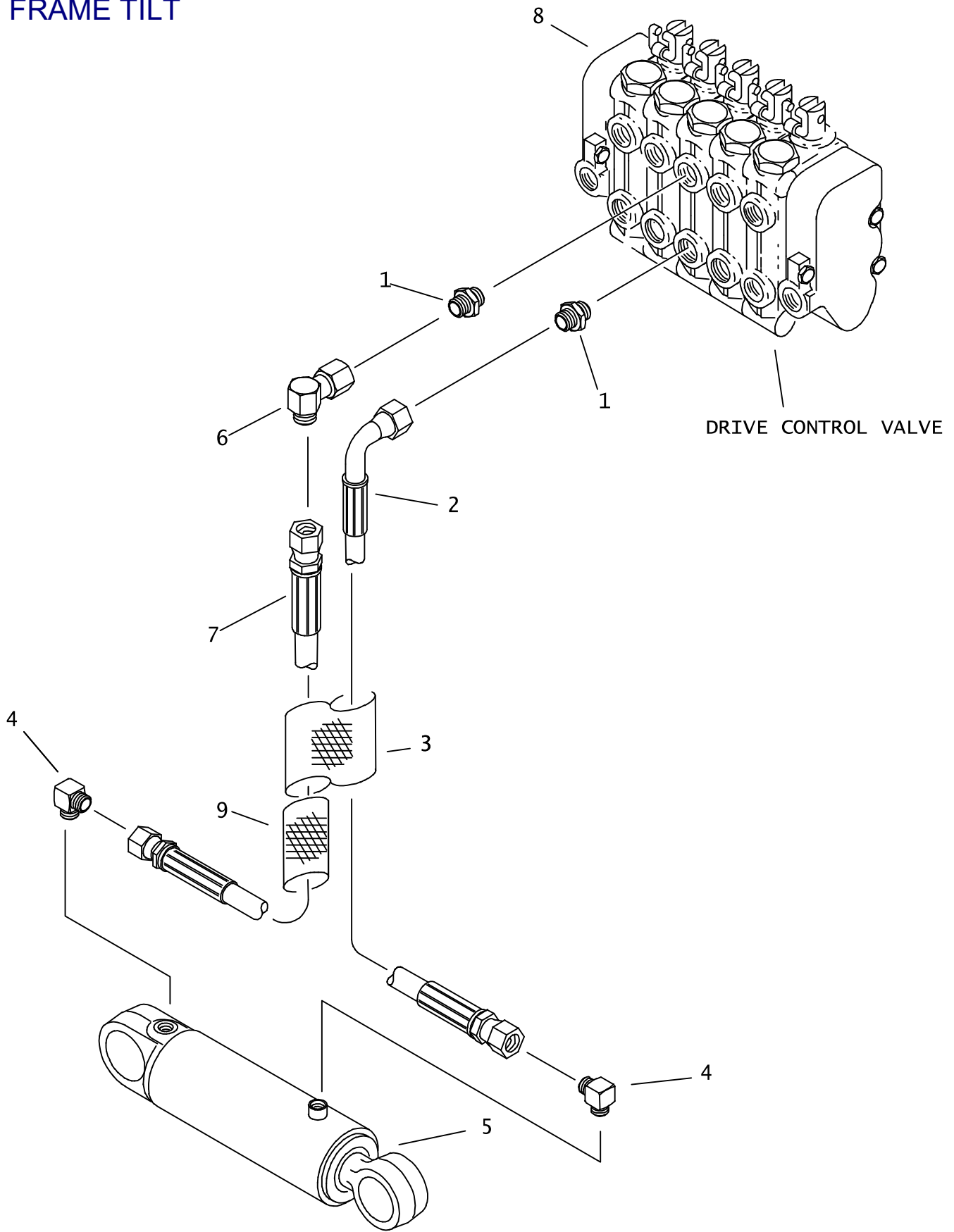

FRAME TILT

REF NO.	PART NUMBER	QTY	DESCRIPTION	REMARKS
1.	154-261	2	CONNECTOR (040-08S)	
2.	515-239	1	HOSE (040FX90-116"-3000)	WITH WATER TANK. USE WITH JT920 & 921
	154-933	1	HOSE (040FX90-94"-3000)	WITHOUT WATER TANK. USE WITH JT921S
3.	116-633	1	ABRASION SLEEVE (1.59" X 115")	WITH WATER TANK. USE WITH JT920 & JT921
	116-787	1	ABRASION SLEEVE (1.59" X 95")	WITHOUT WATER TANK. USE WITH JT921S
4.	154-226	2	CONNECTOR (040-06S90)	WITHOUT WATER TANK. USE WITH JT921S
5.	151-054	1	CYL (3.0" X 1.50" X 4.000")	
6.	154-255	1	UNION (040-040FX90)	WITH WATER TANK. USE WITH JT920 & JT921
7.	154-742	1	HOSE (040FX-130"-3000)	WITH WATER TANK. USE WITH JT920 & JT921S
	155-488	1	HOSE (040FX90-106"-3000)	WITHOUT WATER TANK. USE WITH JT921S
8.	158-937	-	HYD CONTROL VALVE (1-SPOOL)	BEGINS WITH S/N 2N2402
	158-801	-	HYD CONTROL VALVE (5-SPOOL)	ENDS WITH S/N 2N2401
9.	117-194	1	ABRASION SLEEVE (1.00" X 16")	

NOT SHOWN:

FOOTNOTES:

NOTE:

REFER TO O-RING CHART (800-301) IN BACK OF THE BOOK FOR REPLACEMENT OF O-RINGS.

TRACK EXTEND HYDRAULICS

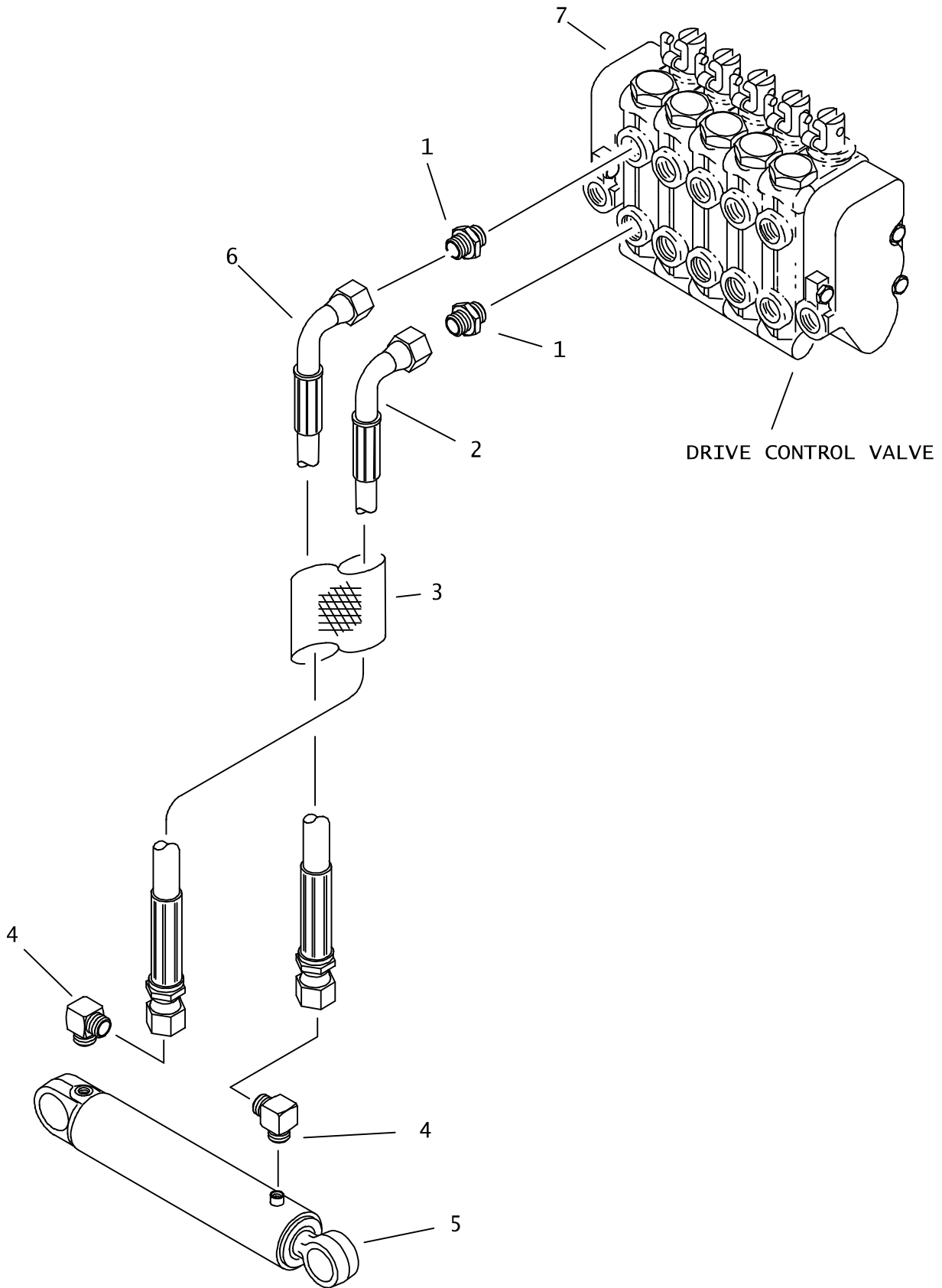

TRACK EXTEND HYDRAULICS

REF NO.	PART NUMBER	QTY	DESCRIPTION	REMARKS
1.	154-261	2	CONNECTOR (040-08S)	
2.	155-488	1	HOSE (040FX90-106"-3000)	WITH WATER TANK
	515-074	1	HOSE(040FX90-77"-3000)	WITHOUT WATER TANK
3.	115-902	1	ABRASION SLEEVE (1.59" X 100")	WITH WATER TANK
	115-935	1	ABRASION SLEEVE (1.75" X 70")	WITHOUT WATER TANK
4.	154-252	2	CONNECTOR (04S-04090)	
5.	151-076	1	CYL (2.0" X 1.00" X 10.00")	
6.	154-771	1	HOSE (040FX90-110"-3000)	WITH WATER TANK
	515-074	1	HOSE (040FX90-77"-3000)	WITHOUT WATER TANK
7.	158-937	-	HYD CONTROL VALVE (-SPOOL)	BEGINS WITH S/N 2N2402

NOT SHOWN:

FOOTNOTES:

NOTE:

REFER TO O-RING CHART (800-301) IN BACK OF THE BOOK FOR REPLACEMENT OF O-RINGS

STABILIZER

JT921/JT921S

DRIVE CONTROL VALVE

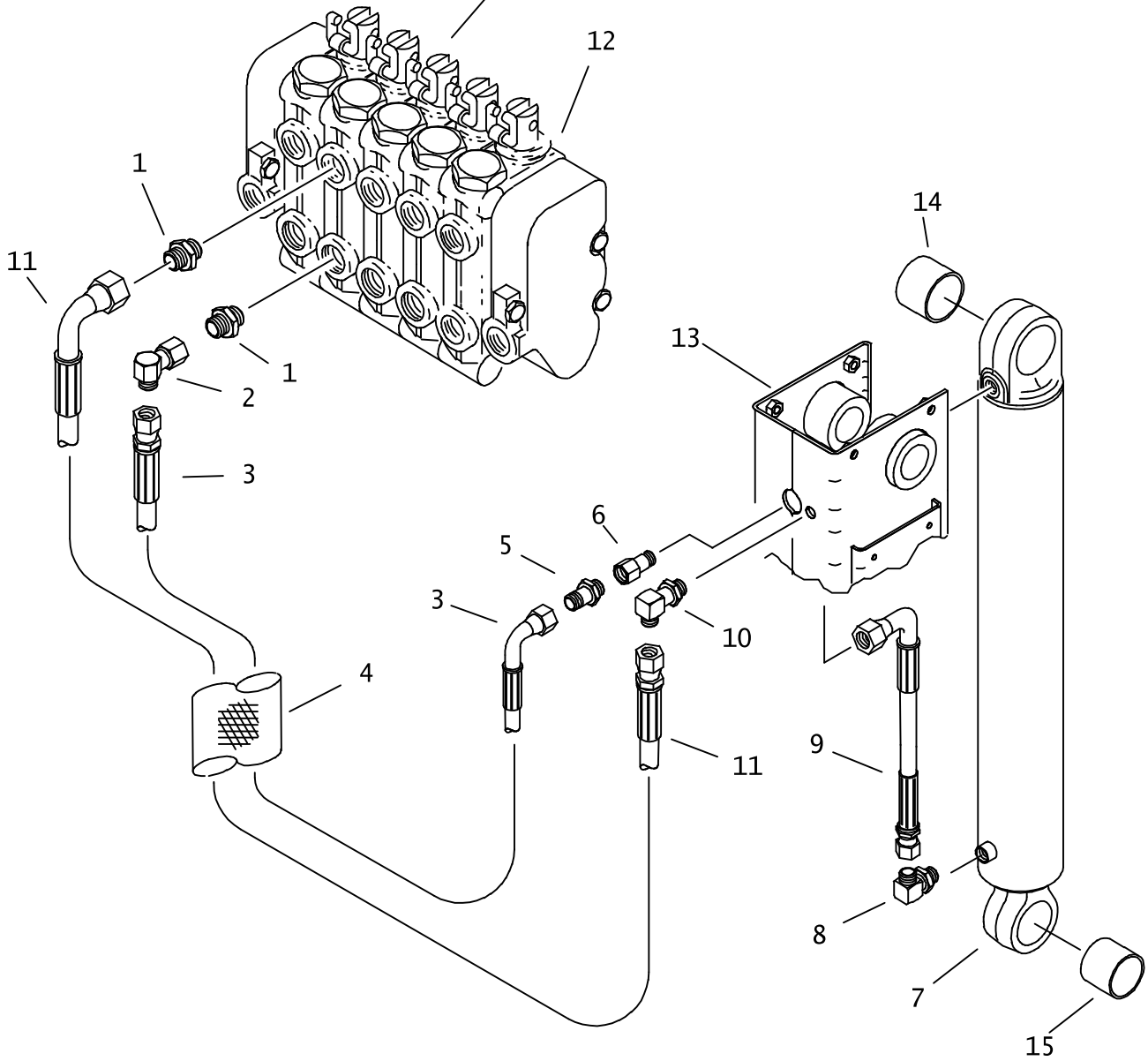

STABILIZER

JT921/JT921S

REF NO.	PART NUMBER	QTY	DESCRIPTION	REMARKS
1.	154-261	2	CONNECTOR (040-08S)	
2.	154-255	1	UNION (040-040FX90)	WITH WATER TANK
3.	515-240	1	HOSE (040FX90-72"-3000)	WITH WATER TANK
	515-210	1	HOSE (040FX90-28"-3000)	WITHOUT WATER TANK
4.	115-935	1	ABRASION SLEEVE (1.75" X 70")	WITH WATER TANK
	115-754	1	ABRASION SLEEVE (1.59" X 30")	WITHOUT WATER TANK
5.	154-403	1	CONNECTOR (04S-040, XL)	
6.	155-254	1	REDUCER (06S-04SF)	
7.	151-147	1	CYL (3" X 1.5" X 20")	
8.	154-226	1	CONNECTOR (040-06S90)	
9.	154-743	1	HOSE (040FX90-23"-3000)	
10.	154-355	1	BK CONNECTOR (040-04090BK)	
11.	515-074	1	HOSE (040FX90-77"-3000)	WITH WATER TANK
	515-744	1	HOSE (040FX90S-28"-3000)	WITHOUT WATER TANK
12.	158-937	-	HYD CONTROL VALVE (_-SPOOL)	
13.	353-289	-	UPPER STABILIZER TUBE	WITHOUT WATER TANK
	353-290	-	UPPER STABILIZER TUBE-WET	WITH WATER TANK
14.	125-773	1	COMPOSITION BUSHING (1.75")	
15.	125-772	1	COMPOSITION BUSHING (1.5")	

FOOTNOTES

NOTE:

REFER TO O-RING CHART (800-301) IN BACK OF THE BOOK FOR REPLACEMENT OF O-RINGS.

MAIN SUPPLY HYDRAULICS

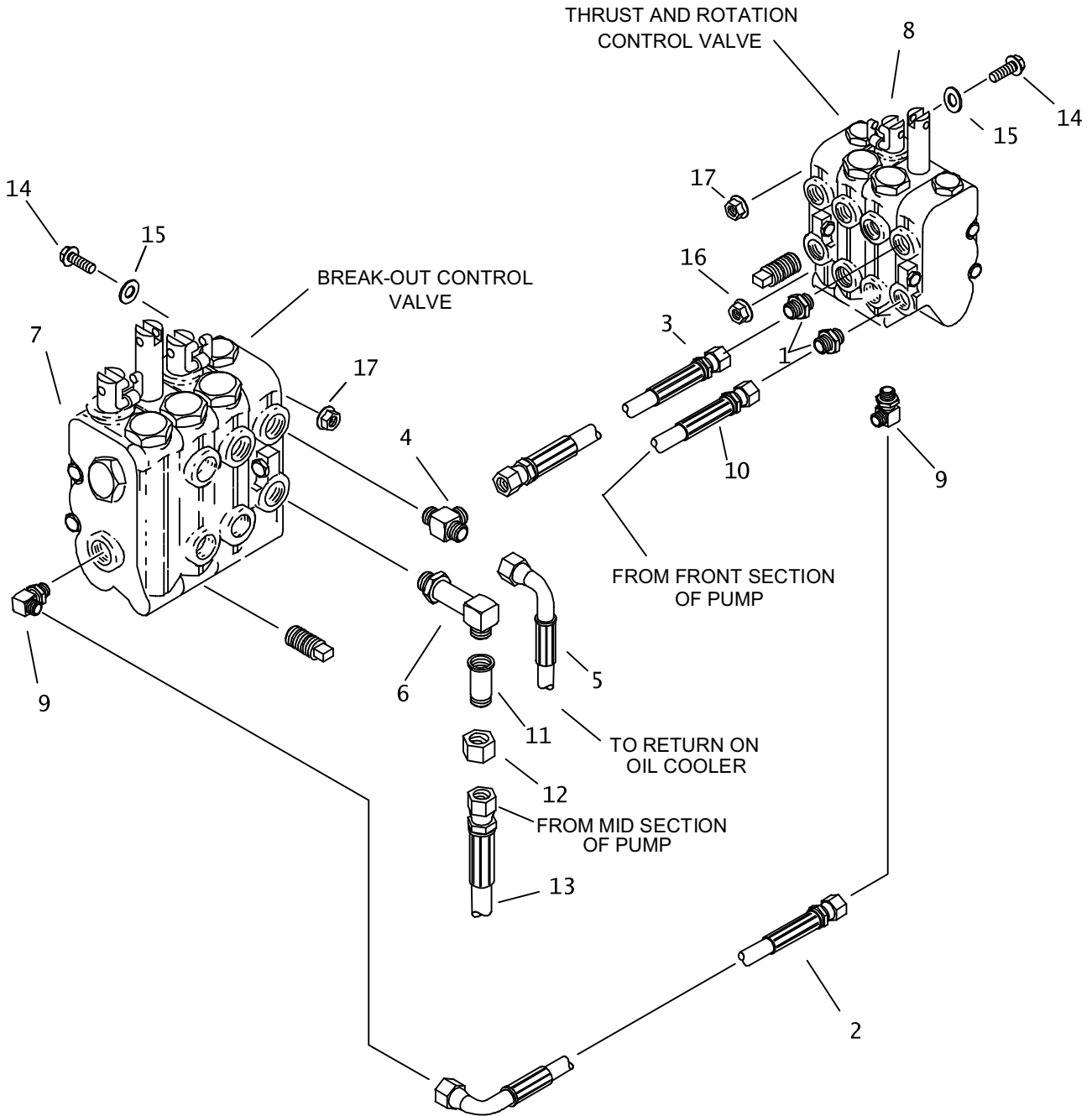

MAIN SUPPLY HYDRAULICS

REF NO.	PART NUMBER	QTY	DESCRIPTION	REMARKS
1.	154-269	2	CONNECTOR (12S-120)	
2.	154-907	1	HOSE (080FX90-32"-3000)	
3.	515-213	1	HOSE (120FX-20"-3000)	
4.	154-292	1	RUN TEE (12S-120-120)	
5.	515-218	1	HOSE (120FX90-80"-3000)	
6.	154-338	1	CONNECTOR (12S-12090, XL)	
7.	516-027	-	HYDRAULIC CONTROL VALVE (2-SPOOL)	
8.	516-124	-	HYDRAULIC CONTROL VALVE 2 SECTION	BEGINS WITH S/N 2N2T1062
9.	154-322	2	CONNECTOR (080-10S90)	
10.	515-242	1	HOSE (120FX90-95"-3000)	
11.	154-249	1	REDUCER STEM (080)	
12.	154-271	1	REDUCER NUT (120F)	
13.	154-902	1	HOSE (080FX90S-66"-3000)	
14.	105-292	6	SCREW (M8-1.25 X 75MM)	
15.	105-117	6	WASHER (5/16")	
16.	106-386	1	FLG LOCKNUT (M8-1.25)	
17.	107-096	5	LOCKNUT (M8-1.25,NLK)	

FOOTNOTES

REFER TO O-RING CHART (800-301) IN BACK OF THE BOOK FOR REPLACEMENT OF ORS AND SAE O-RINGS,

NOTE:

HYDRAULIC CONTROL VALVE 2-SPOOL

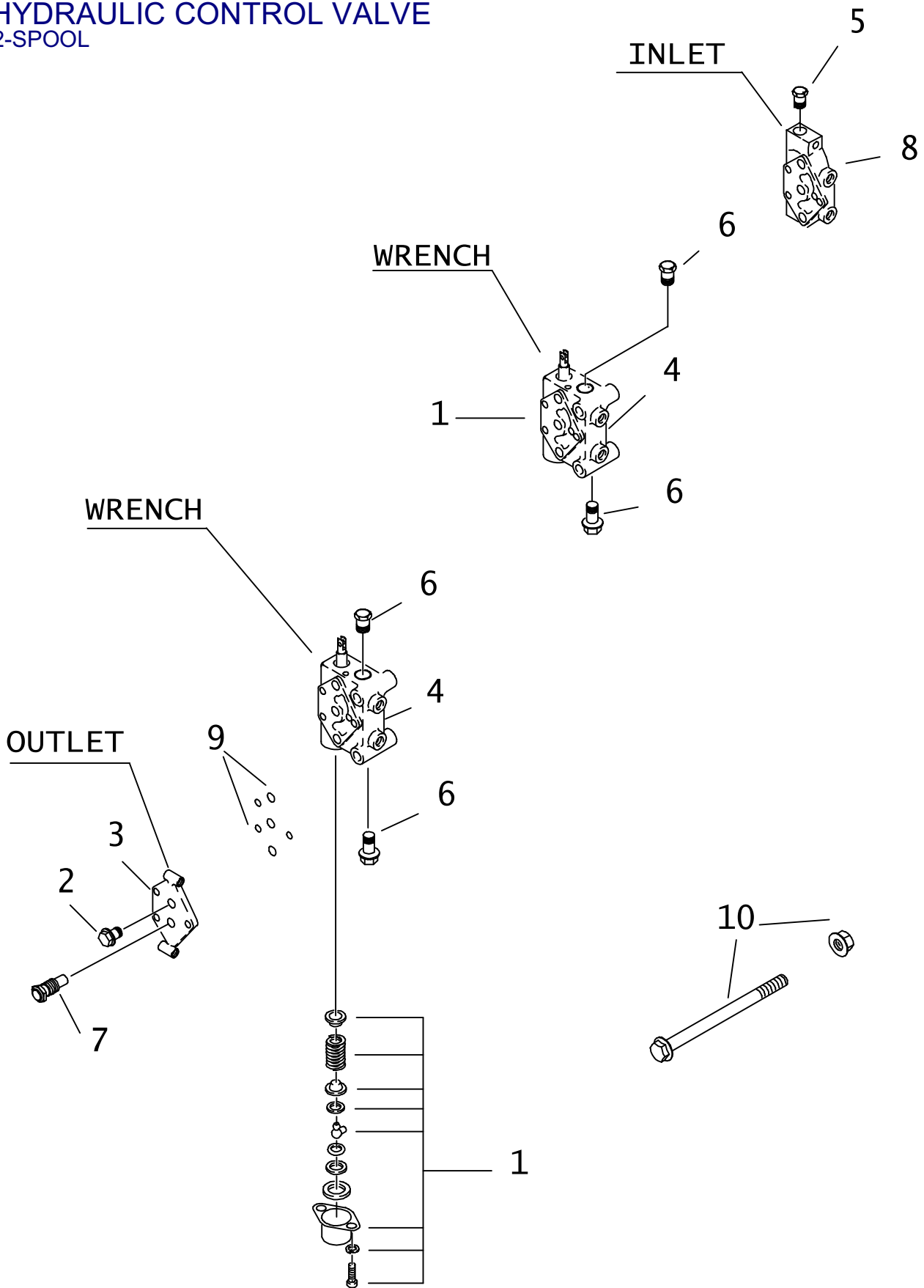

HYDRAULIC CONTROL VALVE 2-SPOOL

REF NO.	PART NUMBER	QTY	DESCRIPTION	REMARKS
	516-027		HYD CONTROL VALVE (2-SPOOL)	INCL REF NO'S 1 THRU 10
1.	500-592	2	STANDARD SPOOL POSITIONER KIT	
2.	500-302	1	PLUG (12S, SOC)	
	155-709		O-RING (912 D90)	
3.	500-951	1	OUTLET COVER	INCL REF NO'S 2, 7 & 9
4.	500-948	2	VALVE SECTION (#_)	
	500-587	2	SPOOL SEAL REPAIR KIT	
	500-949	2	SECTION SERVICE REPAIR KIT	INCL REF NO 9
5.	500-580	1	NR MAIN RELIEF PLUG KIT	
	500-581	1	SEAL REPAIR KIT	
6.	500-962	4	RC RELIEF CARTRIDGE (500PSI)	
	500-585		SEAL REPAIR KIT	
	500-950	1	RELIEF CARTRIDGE SEAL REPAIR KIT	
7.	500-952	1	POWER BEYOND SLEEVE KIT	
8.	N/A		INLET COVER	
9.	500-588	3	SECTIONAL O-RING REPAIR KIT	
10.	500-582	3	TIE-BOLT KIT (2-SECTION)	SEE FOOTNOTE 1
	<u>500-418</u>		BOLT (3/8-NC X 6")	
	105-053		NUT (3/8-NC)	

NOT SHOWN:

499-179 CLEVIS ADAPTER

FOOTNOTES:

I. TORQUE TO 32 FT LBS, INCL'S 3 BOLTS & 3 NUTS.

NOTE:

CONTROL VALVE/LEVERS - 3-SPOOL

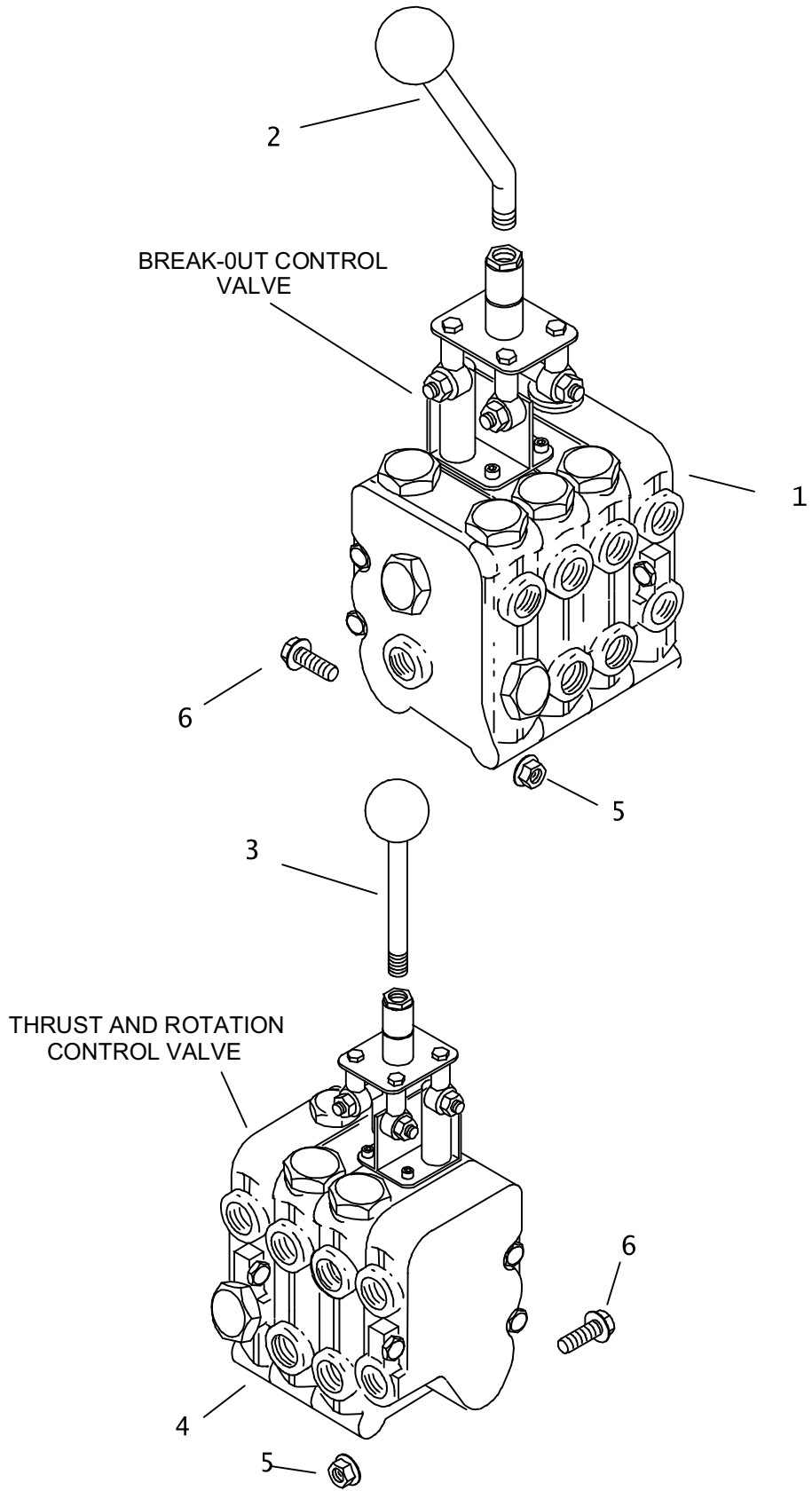

CONTROL VALVE/LEVERS - 3-SPOOL

REF NO.	PART NUMBER	QTY	DESCRIPTION	REMARKS
1.	516-027	1	HYD CONTROL VALVE (2-SPOOL)	
	110-575	3	ROD END	
	105-213	3	LOCK NUT	
	499-020	1	STUD, ROD END	
	499-019	1	SCREW, ROD END	
	499-018	1	SLIDE, ROD END	
	500-965	-	JOYSTICK TOWER	
	499-021	3	SPACER	
	499-179	1	CLEVIS ADAPTER ASS'Y	
2.	185-146	1	JOYSTICK LEVER (OFFSET)	
3.	185-145	1	JOYSTICK LEVER (STRAIGHT)	
4.	516-124	1	HYD CONTROL VALVE 2 SECTION	BEGINS WITH S/N N2T1062
5.	107-096	6	LOCKNUT (M8-1.25 NLK)	
6.	106-206	6	SCREW (M10-1.50 X 90mm)	

FOOTNOTES

NOTE:

F

805-044

HYDRAULIC CONTROL VALVE (2-SPOOL)

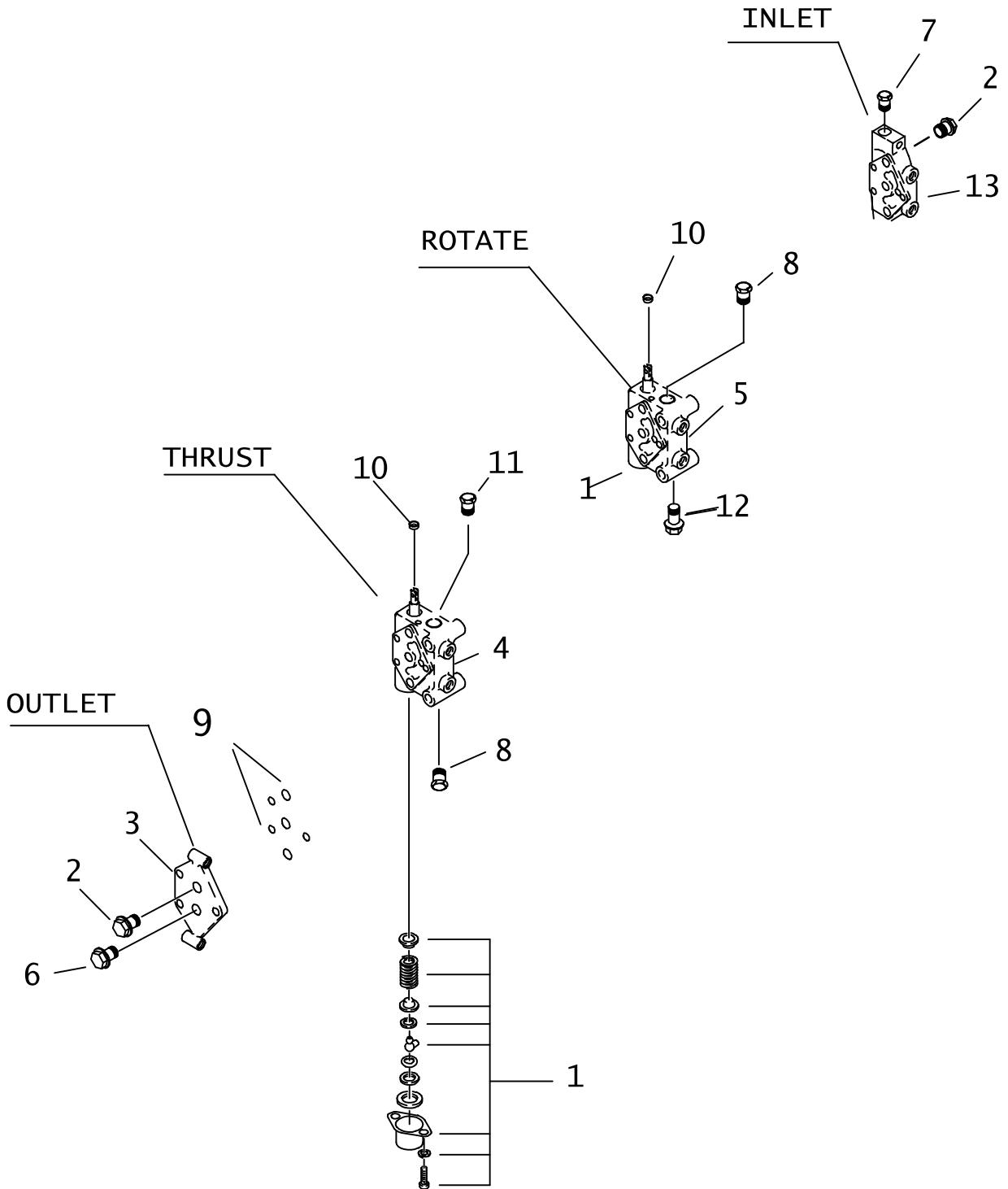

HYDRAULIC CONTROL VALVE (2-SPOOL)

REF NO.	PART NUMBER	QTY	DESCRIPTION	REMARKS
	516-124		HYD CONTROL VALVE (2-SPOOL)	
	500-588	4	SECTIONAL O-RING REPAIR KIT	INCL REF NO'S. 1 THRU 16
1.	500-592	2	STANDARD SPOOL POSITIONER KIT	
2.	500-302	2	PLUG (12S, SOC)	
	155-709		O-RING (912 D90)	
3.	500-961	1	OUTLET COVER	INCL REF NO'S. 2, 14 & 15
4.	500-960	1	VALVE SECTION (#)	
	500-949		SECTION SERVICE REPAIR KIT	INCL REF NO 14
5.	500-959	1	VALVE SECTION (#)	
	500-949		SECTION SERVICE REPAIR KIT	INCL REF NO 14
6.	155-074	1	PLUG (08S, SOC, FM)	
	155-706		O-RING (908 D90)	
7.	500-956	1	WH RELIEF CARTRIDGE (3000PSI)	
	500-957		SEAL REPAIR KIT	
8.	500-321	2	LOAD CHECK PLUG KIT	
	500-585		SEAL REPAIR KIT	
9.	500-588	4	SECTIONAL O-RING REPAIR KIT	
10.	500-587	4	SPOOL SEAL REPAIR KIT	
11.	499-402	1	PORT RELIEF CARTRIDGE 2750 ADJ	F/N 2
	500-585	1	SEAL REPAIR KIT	
12.	499-406	1	PORT RELIEF CARTRIDGE 2550 ADJ	F/N 3
	500-585	1	SEAL REPAIR KIT	
13.	N/A	1	INLET COVER	

FOOTNOTES

1. TORQUE TO 32 FT LBS. INCLS 3 BOLTS & 3 NUTS
2. SET AT 2750 PSI - ADJUSTABLE FROM 2550 TO 2750 PSI
3. SET AT 2550 PSI - ADJUSTABLE FROM 2550 TO 2750 PSI

NOTE:

E

807-271

CONTROL VALVE/LEVERS

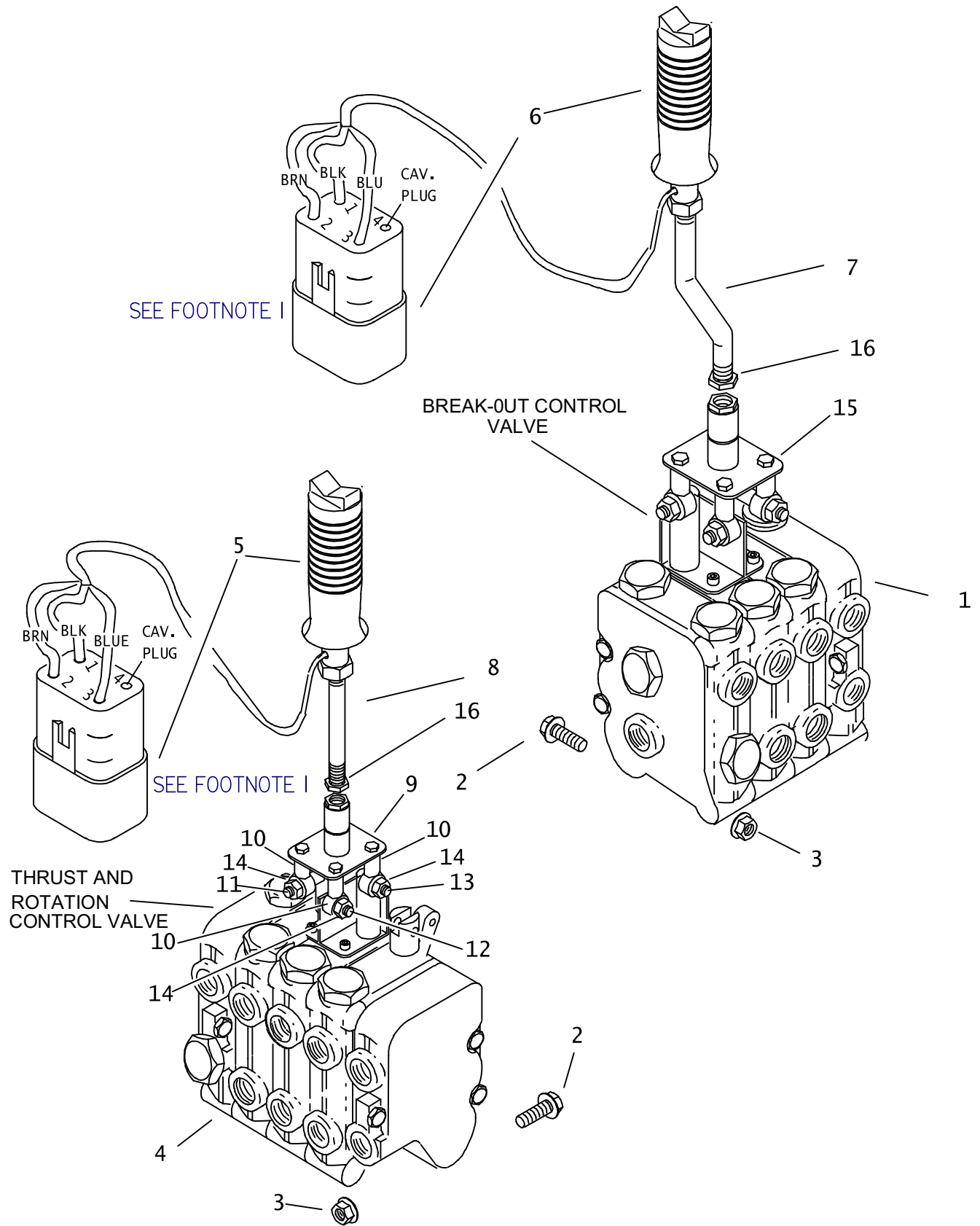

CONTROL VALVE/LEVERS

REF NO.	PART NUMBER	QTY	DESCRIPTION	REMARKS
1.	516-027	1	HYDRAULIC CONTROL VALVE (2-SPOOL)	
2.	106-206	6	SCREW (M10-1.5 X 90)	
3.	107-096	6	LOCKNUT (M8-1.25, NLK)	
4.	516-028	1	HYDRAULIC CONTROL VALVE (3-SPOOL)	
5.	214-466	1	JOYSTICK (ON-OFF-(ON))	
	501-822	-	JOYSTICK (ON-OFF-(ON))	
	217-946		MICRO SWITCH (JOYSTICK)	
	214-133	-	TERMINAL PIN (DEUTSCH)	
	217-202	-	CAVITY PLUG-DEUTSCH	
	217-203	-	4-WAY MALE LOCK-DEUTSCH	
	217-204	-	4-WAY MALE CONN. (DEUTSCH)	
	308-646	-	ROCKER BOOT (RUBBER)	
6.	214-467	1	JOYSTICK (ON-OFF-ON)	
	501-823	-	JOYSTICK (ON-OFF-(ON))	
	217-946		MICRO SWITCH (JOYSTICK)	
	214-133	-	TERMINAL PIN (DEUTSCH)	
	217-202	-	CAVITY PLUG-DEUTSCH	
	217-203	-	4-WAY MALE LOCK-DEUTSCH	
	308-646	-	ROCKER BOOT (RUBBER)	
7.	185-146	1	JOYSTICK LEVER (OFFSET)	
8.	185-145	1	JOYSTICK LEVER (STRAIGHT)	
9.	500-965	1	L.H. JOYSTICK 'TOWER'	
10.	110-575	6	ROD END (5/16-NF, FM)	
11.	499-018	2	"SLIDE" BOLT ROD END	
12.	499-019	2	SCREW ROD END	
13.	499-020	2	STUD (ROD END)	
14.	105-213	6	NUT (5/16-NF)	
15.	217-271	1	R.H. JOYSTICK "TOWER"	
16.	105-044	2	JAM NUT (1/2-NC)	

NOT SHOWN:

FOOTNOTES:

I. SUPPLIER CHANGE WIRE COLOR ON JOYSTICK. RED IS NOW BLUE, GREY IS NOW BLACK AND YELLOW IS NOW BROWN.

NOTE:

CARRIAGE ROTATION HYDRAULICS

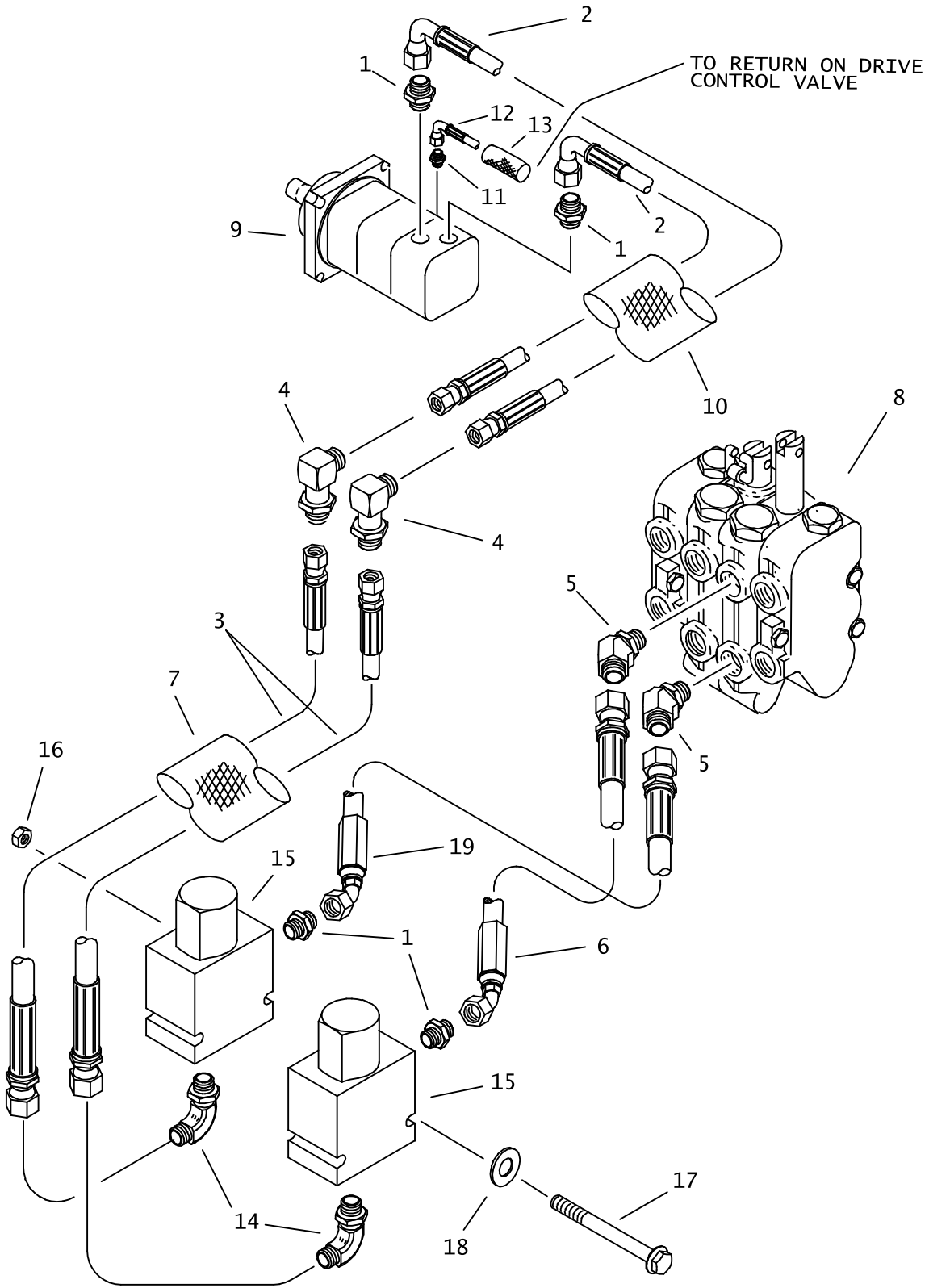

CARRIAGE ROTATION HYDRAULICS

REF NO.	PART NUMBER	QTY	DESCRIPTION	REMARKS
1.	154-308	4	CONNECTOR (100-12S)	
2.	515-432	2	HOSE (100FX90S-154"-3000)	
3.	515-436	2	HOSE (100F-112"-3000)	SEE FOOTNOTE 1
	154-870	2	HOSE(100FX-84"-2750)	SEE FOOTNOTE 2
4.	514-090	2	CONNECTOR (100-10090)	
5.	154-399	2	CONNECTOR (10S-10045)	
6.	515-048	1	HOSE (100FX45-18"-3000)	
7.	117-683	1	ABRASION SLEEVE (2.38" X 84")	
8.	516-124	-	HYD CONTROL VALVE 2 SECTION	BEGINS WITH S/N 2N2T1062
9.	158-881	-	HYDRAULIC MOTOR	
10.	117-843	1	ABRASION SLEEVE (2.38" X 164")	
11.	154-278	1	CONNECTOR (04S-040)	
12.	515-185	1	HOSE (040FX90M-238"-3000)	
13.	117-841	1	ABRASION SLEEVE (1.00" X 164")	
14.	154-300	2	CONNECTOR (100-12S90)	
15.	149-495	2	ASS'Y HYD. SOLENOID VALVE	
	149-496	1	STEEL, MANIFOLD BLOCK	
	155-724	-	O-RING (217 D70)	
	217-941	1	SOLENOID COIL	
	500-620	1	SEAL REPAIR KIT	
16.	106-561	2	LOCKNUT (M8-1.25,PRV TRQ,10.9)	
17.	106-160	2	FLG LK SCREW (M8-1.25 X 120MM)	
18.	105-117	2	WASHER (5/16")	
19.	153-907	1	HOSE (100FX45-16"-3000)	

FOOTNOTES

1. USED WITHOUT OPERATORS PRESENCE SWITCH
2. USED WITH OPERATORS PRESENCE SWITCH

NOTE:

REFER TO O-RING CHART (800-301) IN BACK OF THE BOOK FOR REPLACEMENT OF O-RINGS.

ROTATION HYDRAULICS

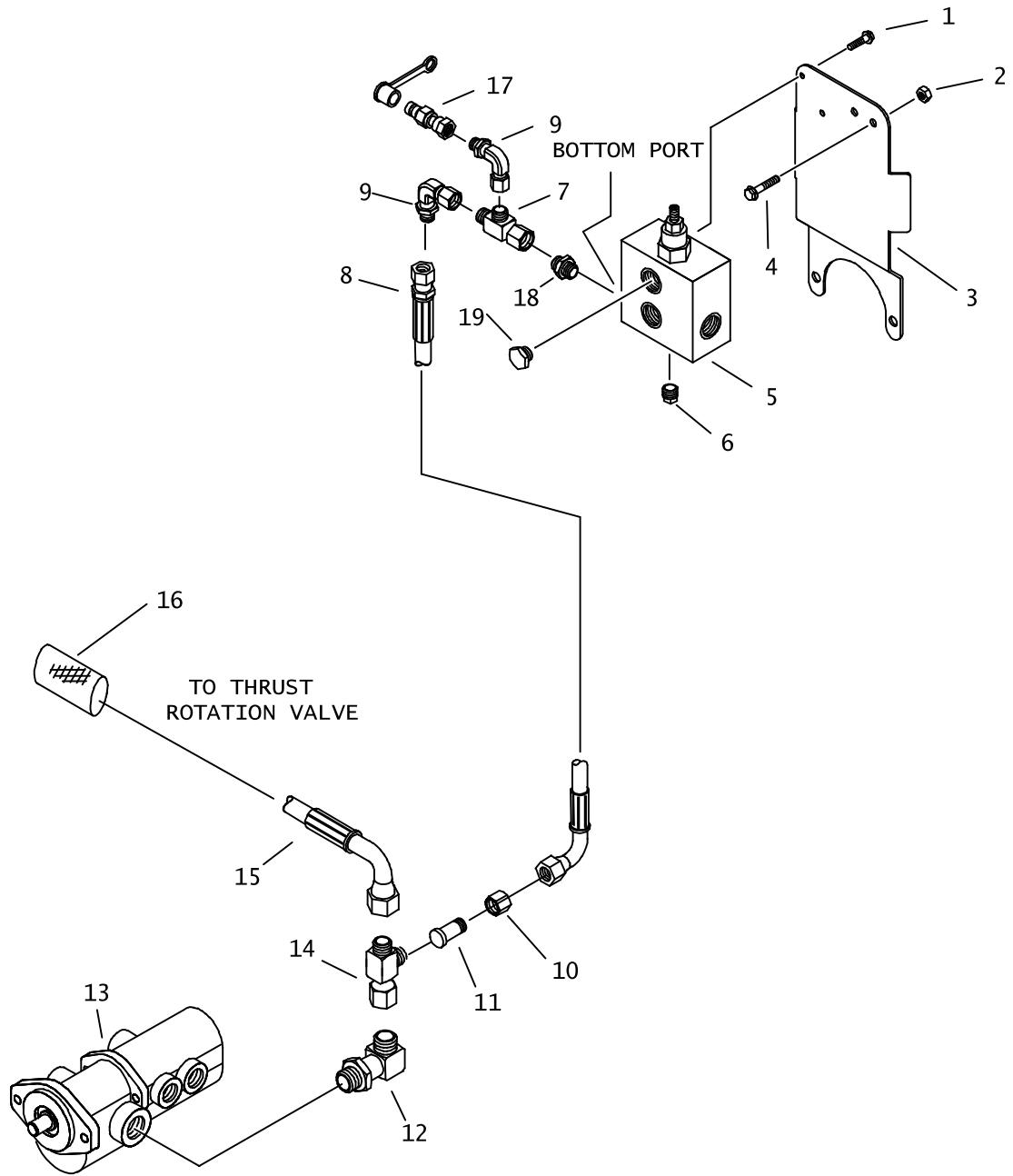

ROTATION HYDRAULICS

REF NO.	PART NUMBER	QTY	DESCRIPTION	REMARKS
1.	501-153	2	FLG LK BOLT (3/8-NC X 5/8")	
2.	105-832	2	FLG LOCKNUT (1/4-NC)	
3.	344-726	2	SUPPORT PLATE	
4.	105-836	2	FLG LOCK BOLT (1/4-NC X 1/2")	
5.	158-814	1	CONTROL VALVE	
	190-643		SEAL REPAIR KIT	
	500-906		VALVE CARTRIDGE (1000PSI)	
6.	115-153	1	PLUG (04N, SQ)	
7.	154-344	1	UNION RUN TEE (060FX-060-060)	
8.	515-583	1	HOSE (060FX90-12"-3000)	
9.	154-228	2	UNION (060-060FX90)	
10.	154-271	1	REDUCER NUT (120F)	
11.	154-459	1	REDUCER STEM (060)	
12.	154-270	1	CONNECTOR (12S-12090)	
13.	158-420	-	HYDRAULIC PUMP	
14.	154-368	1	UNION RUN TEE (120FX-120-120)	
15.	515-242	2	HOSE (120FX90-95"-3000)	
16.	115-924	1	ABRASION SLEEVE (1.59" X 88")	
17.	159-157	1	QDC ADAPTER (02-060F)	
	159-148	1	DUST CAP (1/8")	
18.	156-067	1	CONNECTOR (06S-060, ORF .031")	
19.	155-130	1	PLUG (06S)	

FOOTNOTES

NOTE:

REFER TO O-RING CHART (800-301) IN BACK OF THE BOOK FOR REPLACEMENT OF SAE AND ORS O-RINGS.

ROTATION HYDRAULICS WITH AUTOBORE SELECT

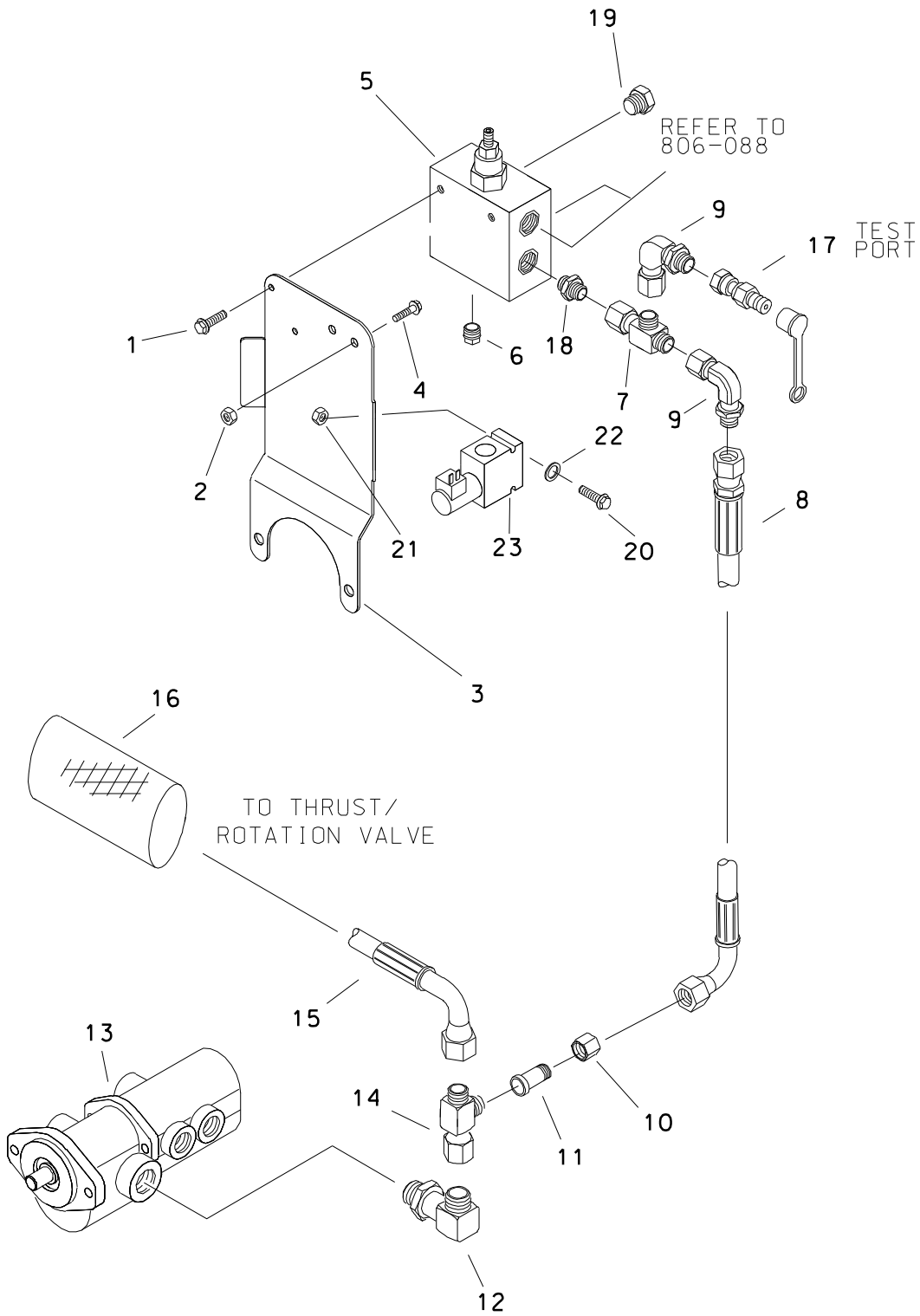

ROTATION HYDRAULICS WITH AUTOBORE SELECT

REF NO.	PART NUMBER	QTY	DESCRIPTION	REMARKS
1.	501-153	2	FLG LK BOLT (3/8-NC X 5/8")	
2.	105-832	2	FLG LOCKNUT (1/4-NC)	
3.	344-726	2	SUPPORT PLATE	
4.	105-836	2	FLG LOCK BOLT (1/4-NC X .500")	
5.	158-814	1	CONTROL VALVE	
	190-643		SEAL REPAIR KIT	
	500-906		CONTROL VALVE CARTRIDGE	
6.	115-153	1	PLUG (O4N, SQ)	
7.	154-344	1	UNION RUN TEE (O60FX-O60-O60)	
8.	515-583	1	HOSE (O60FX90-12"-3000)	
9.	154-228	2	UNION (O60-O60FX90)	
10.	154-271	1	REDUCER NUT (120F)	
11.	154-459	1	REDUCER STEM (O60)	
12.	154-270	1	CONNECTOR (12S-12090)	
13.	158-420		HYDRAULIC PUMP	
14.	154-368	1	UNION RUN TEE (120FX-120-120)	
15.	154-957	1	HOSE (120FX90-92"-3000)	
16.	117-764	1	ABRASION SLEEVE (1.59" X 90")	
17.	159-157	1	QDC ADAPTER (O2-O60F)	
	159-148	1	DUST CAP (1/8")	
18.	156-067	1	CONNECTOR (O6S-O60, DRF)	
19.	155-130	1	PLUG (O6S)	
20.	106-093	2	SCREW (M6-1.00 X 45MM)	
21.	106-237	2	NUT (M6-1.00, PRV TRQ, NLK)	
22.	106-288	2	STUDBOLT (1/4-NC X 3/32", GD8)	
23.	158-569		SOLENOID DIVERSION VALVE	

FOOTNOTES

NOTE

REFER TO O-RING CHART (800-301) IN BACK OF THE BOOK FOR REPLACEMENT OF O-RINGS.

CARRIAGE THRUST HYDRAULICS

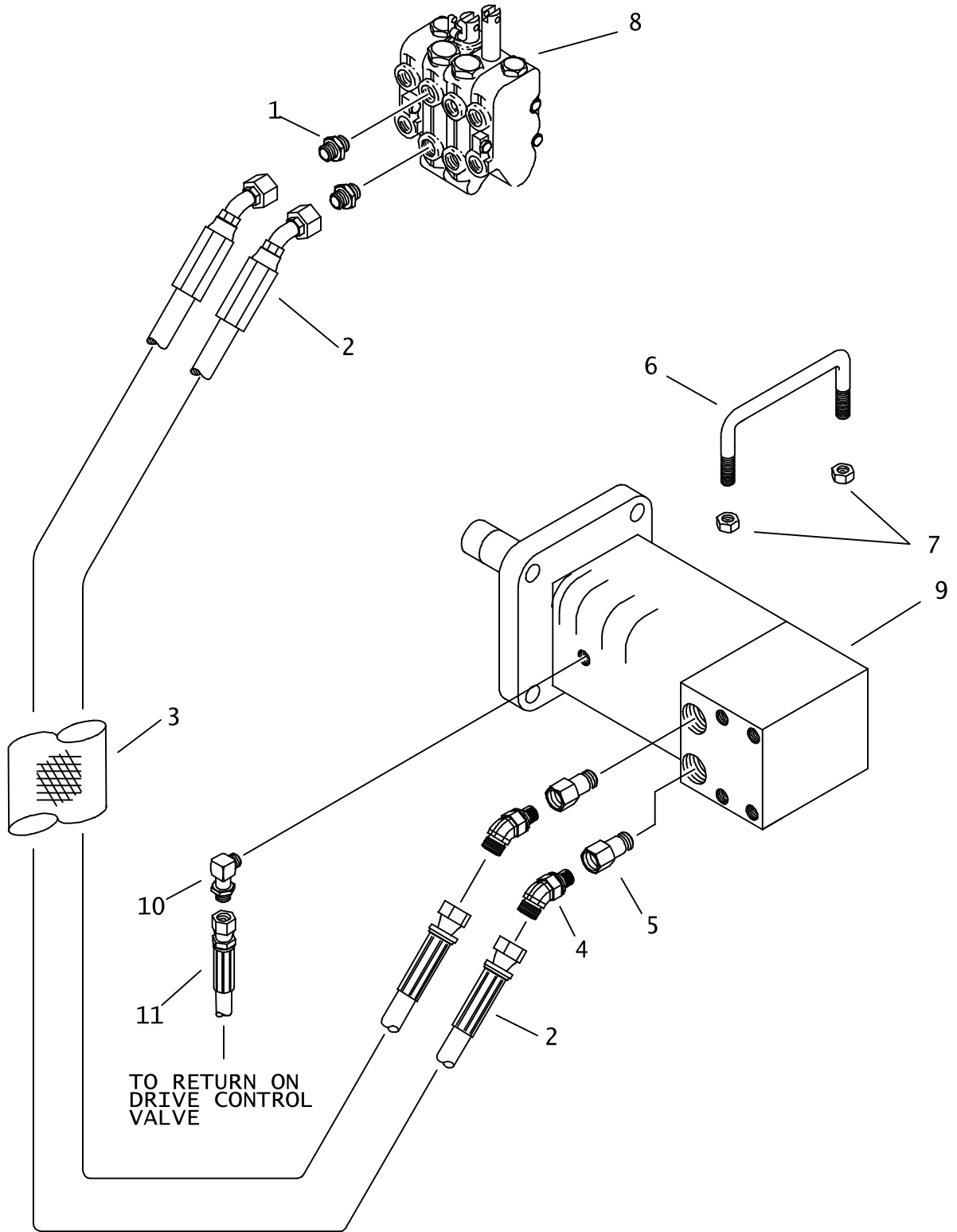

CARRIAGE THRUST HYDRAULICS

REF NO.	PART NUMBER	QTY	DESCRIPTION	REMARKS
1.	154-301	2	CONNECTOR (10S-100)	
2.	515-216	2	HOSE (100FX45-132"-3000)	
3.	117-842	1	ABRASION SLEEVE (2.38" X 128")	
4.	154-470	2	CONNECTOR (100-12S45)	
5.	155-222	2	REDUCER (16S-12SF)	
6.	355-586	1	HOSE RETAINER	
7.	106-385	4	FLG LOCKNUT (M6-1.00)	
8.	516-124	-	HYD CONTROL VALVE (2-SPOOL)	BEGINS WITH S/N 2N2T1062
9.	158-908	-	HYD MOTOR (THRUST, 8600#)	
	190-728	-	SEAL REPAIR KIT	
10.	154-226	1	CONNECTOR (040-06S90)	WITH WATER TANK
	154-220	1	CONNECTOR (040-06S)	WITHOUT WATER TANK
11.	154-921	1	HOSE (040FX-54"-3000-AR)	

NOT SHOWN:

FOOTNOTES:

NOTE:

REFER TO O-RING CHART (800-301) IN BACK OF THE BOOK FOR REPLACEMENT OF O-RINGS.

THRUST HYDRAULICS

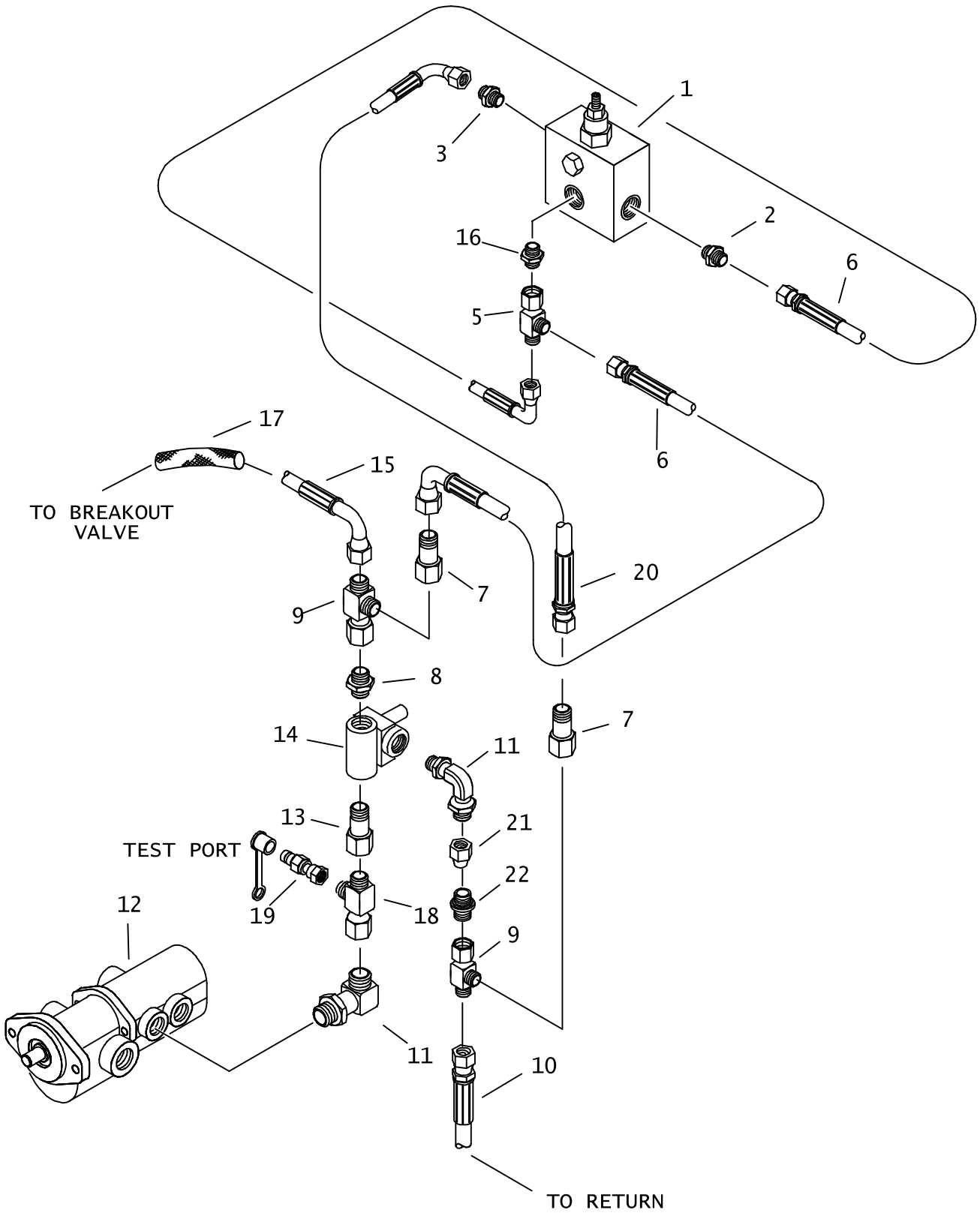

THRUST HYDRAULICS

REF NO.	PART NUMBER	QTY	DESCRIPTION	REMARKS
1.	158-814	-	CONTROL VALVE	
	190-643	-	SEAL REPAIR KIT	
	500-906	1	CONTROL VALVE CARTRIDGE	
2.	156-066	1	CONNECTOR (06S-060, ORF)	
3.	156-065	1	CONNECTOR (06S-060, ORF)	
4.	159-157	1	QDC ADAPTER (02-060F)	
	159-148	1	DUST CAP (1/8")	
5.	154-344	1	UNION RUN TEE (060FX-060-060)	
6.	154-737	1	HOSE (060FX90-17"-3000)	
7.	154-262	2	REDUCER (060-080F)	
8.	154-279	1	CONNECTOR (080-10S)	
9.	154-266	2	UNION RUN TEE (080FX-080-080)	
10.	154-942	1	HOSE (080FX90-13"-3000)	
11.	154-298	2	CONNECTOR (100-10S90)	
12.	158-420	1	HYDRAULIC PUMP	
13.	514-079	1	UNION (10S-100FX)	
14.	153-675	1	ADJ HYD RELIEF VALVE 3000 PSI	BEGIN WITH S/N 2V0571
	153-219	-	WH-A RELIEF CARTRIDGE (3000PSI)	
15.	154-971	1	HOSE (080FX90-78"-3000)	
16.	154-221	1	CONNECTOR (06S-060)	
17.	117-713	1	ABRASION SLEEVE (1.00" X 76")	
18.	154-488	1	UN RUN TEE (100FX-100-100)	
19.	159-159	1	QDC ADAPTER (02-100FX)	
	159-148	1	DUST CAP (1/8")	
20.	515-583	1	HOSE (060FX90-12"-3000)	
21.	154-310	1	REDUCER NUT (100F)	
22.	154-312	1	REDUCER STEM (080)	

FOOTNOTES

NOTE:

REFER TO O-RING CHART (800-301) IN BACK OF THE BOOK FOR REPLACEMENT O-RINGS.

THRUST HYDRAULICS WITH AUTOBORE SELECT

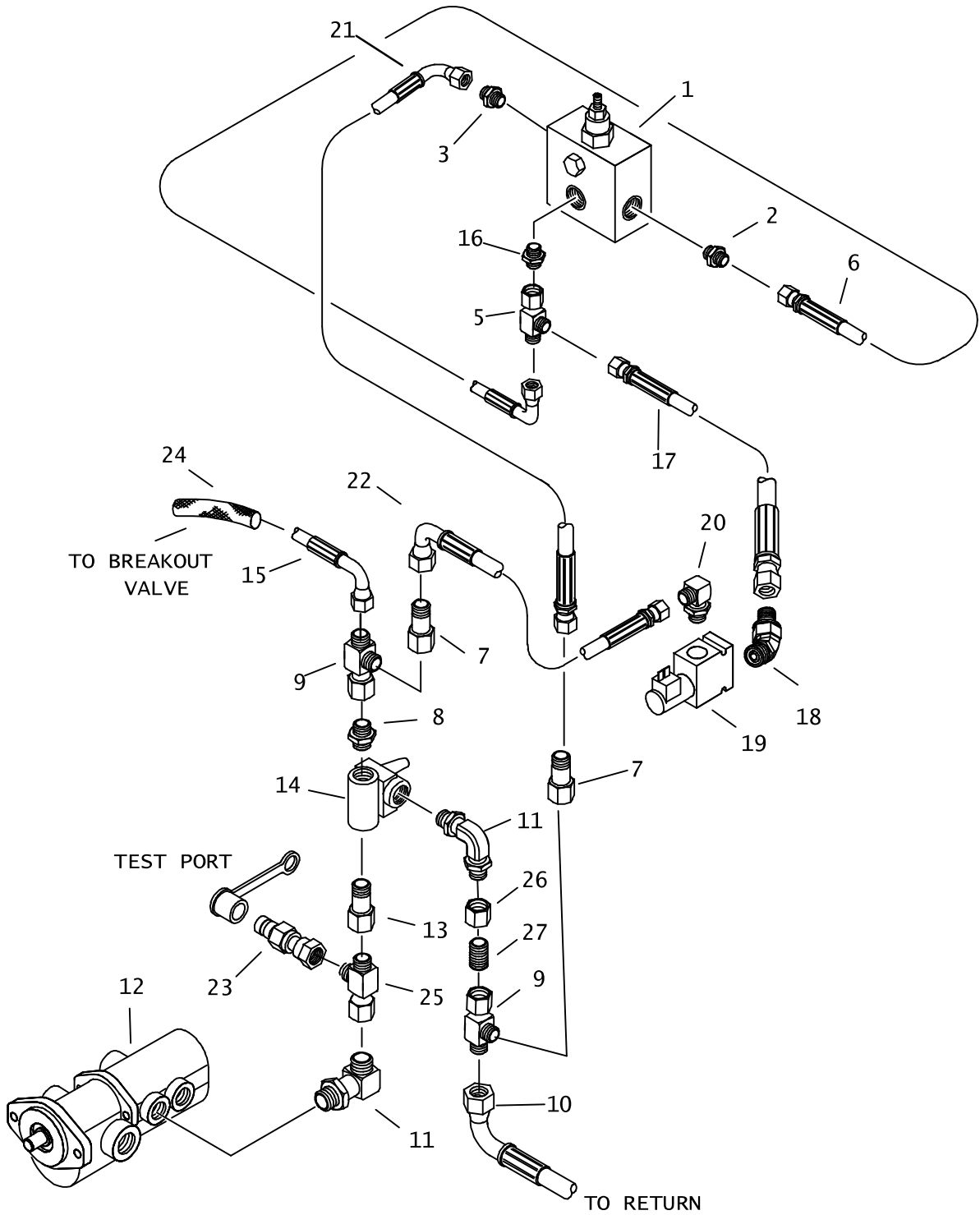

THRUST HYDRAULICS WITH AUTOBORE SELECT

REF NO.	PART NUMBER	QTY	DESCRIPTION	REMARKS
1.	158-814	-	CONTROL VALVE	
2.	156-066	1	CONNECTOR (06S-060, ORF)	
3.	156-065	1	CONNECTOR (06S-060, ORF)	
4.	159-157	1	QDC ADAPTER (02-060F)	
	159-148	1	DUST CAP (1/8")	
5.	154-344	2	UNION RUN TEE (060FX-060-060)	
6.	154-737	1	HOSE (060FX90-17"-3000)	
7.	154-262	2	REDUCER (060-080F)	
8.	154-279	1	CONNECTOR (080-10S)	
9.	154-266	2	UNION RUN TEE (080FX-080-080)	
10.	154-942	1	HOSE (080FX90S-13"-3000)	
11.	154-298	2	CONNECTOR (10S-10090)	
12.	158-420	1	HYDRAULIC PUMP	
13.	514-079	1	UNION (10S-100FX)	
14.	153-675	1	ADJ HYD RELIEF VALVE 3000PSI	BEGINS WITH S/N 2V0571
	153-219	-	WH-A RELIEF CARTRIDGE	
15.	154-971	1	HOSE (080FX90-78"-3000)	
16.	154-221	1	CONNECTOR (06S-060)	
17.	154-731	1	HOSE (060FX-17"-3000)	
18.	154-225	1	CONNECTOR (060-08S45)	
19.	158-569	1	SOLENOID DIVERSION VALVE	
20.	154-227	1	CONNECTOR (060-08S90)	
21.	515-583	1	HOSE (060FX90-12"-3000)	
22.	515-377	1	HOSE (060FX90-9"-3000)	
23.	159-159	1	QDC ADAPTER (02-100FX)	
	159-148	1	DUST CAP (1/8")	
24.	117-713	1	ABRASION SLEEVE (1.00" x 76")	
25.	154-488	1	UN RUN TEE (100FX-100-100)	
26.	154-310	3	REDUCER NUT (100F)	
27.	154-312	3	REDUCER STEM (080)	

FOOTNOTES

NOTE:

REFER TO O-RING CHART (800-301) IN BACK OF THE BOOK FOR REPLACEMENT OF O-RINGS.

BREAKOUT HYDRAULICS

BEGINS WITH S/N 2P0770

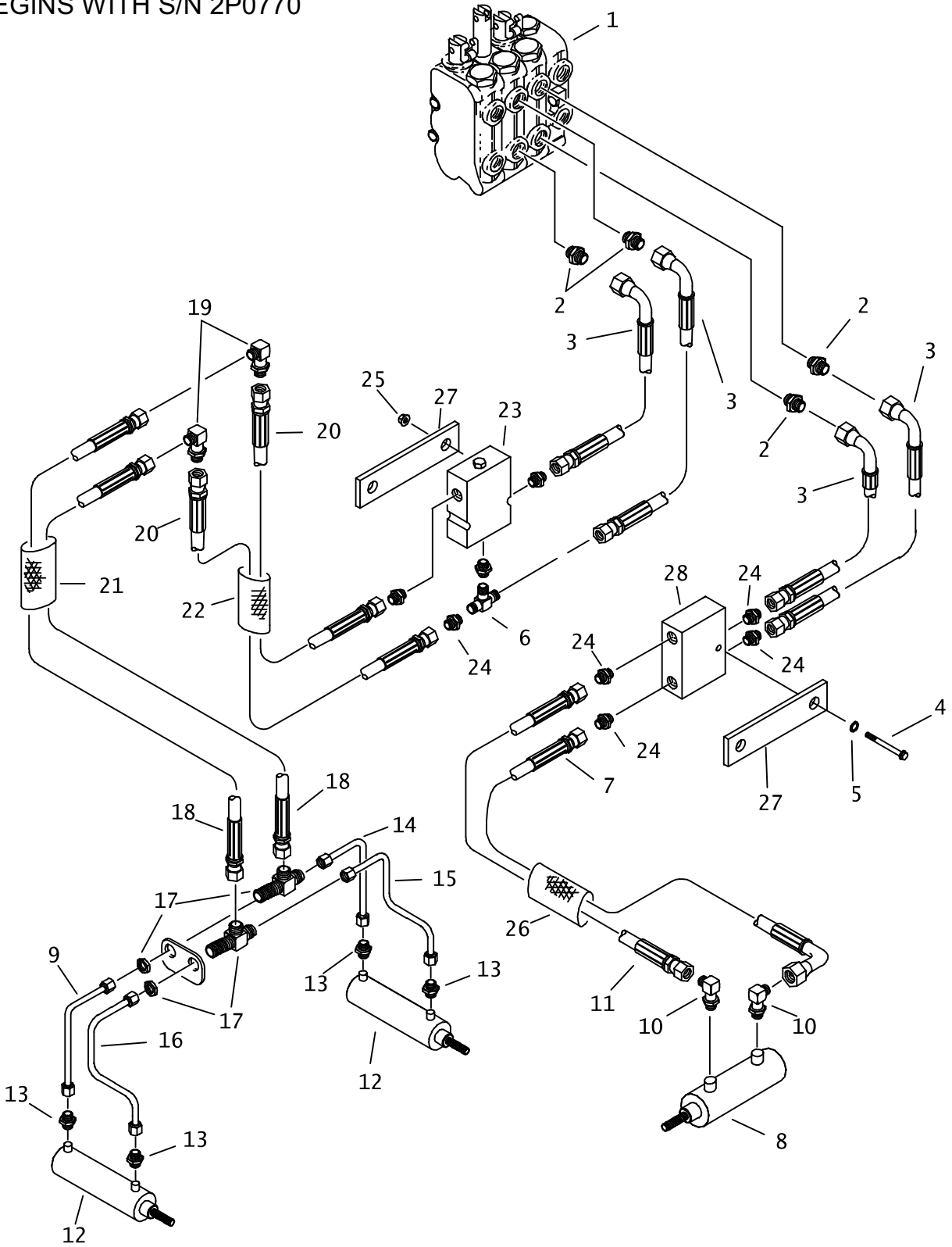

BREAKOUT HYDRAULICS BEGINS WITH S/N 2P0770

REF NO.	PART NUMBER	QTY	DESCRIPTION	REMARKS
1.	516-027	-	HYD CONTROL VALVE (2-SPOOL)	
2.	154-261	4	CONNECTOR (040-08S)	
3.	154-727	4	HOSE (040FX90-30"-3000)	
4.	105-843	2	SCREW (M6-1.00 X 80mm)	
5.	106-076	2	WASHER (1/4")	
6.	154-379	1	UN BR TEE (040FX-040-040)	
7.	515-189	1	HOSE (040FX90L-88"-3000)	
8.	150-725	1	CYL (1" X 2.5")	
9.	156-860	1	HYD LINE (-04)	
10.	154-252	2	CONNECTOR (04S-04090)	
11.	154-725	1	HOSE (040FX-90"-3000)	
12.	150-724	-	CYL (1" X 2")	
13.	154-278	4	CONNECTOR (04S-040)	
14.	156-861	1	HYD LINE (-04)	
15.	156-862	1	HYD LINE (-04)	
16.	156-863	1	HYD LINE (-04)	
17.	154-424	-	BK RUN TEE (040-040-040BK)	
18.	515-433	2	HOSE (040FX-144"-3000)	
19.	154-355	2	BK CONNECTOR (040-04090BK)	
20.	154-725	2	HOSE (040FX-90"-3000)	
21.	117-741	1	ABRASION SLEEVE (1.59" X 145")	
22.	115-924	1	ABRASION SLEEVE (1.59" X 88")	
23.	155-259	2	CHECK VALVE	
24.	154-220	7	CONNECTOR (040-06S)	
25.	106-353	2	FLG NUT (M6-1.00)	
26.	115-817	1	ABRASION SLEEVE (1.59" X 84")	
27.	338-101	2	CLAMP STRAP	
28.	155-623	1	DOUBLE LOCKOUT VALVE	

FOOTNOTES

NOTE:

REFER TO O-RING CHART (800-301) IN BACK OF THE BOOK FOR REPLACEMENT OF O-RINGS.

AUXILIARY BACKUP WRENCH HYDRAULICS

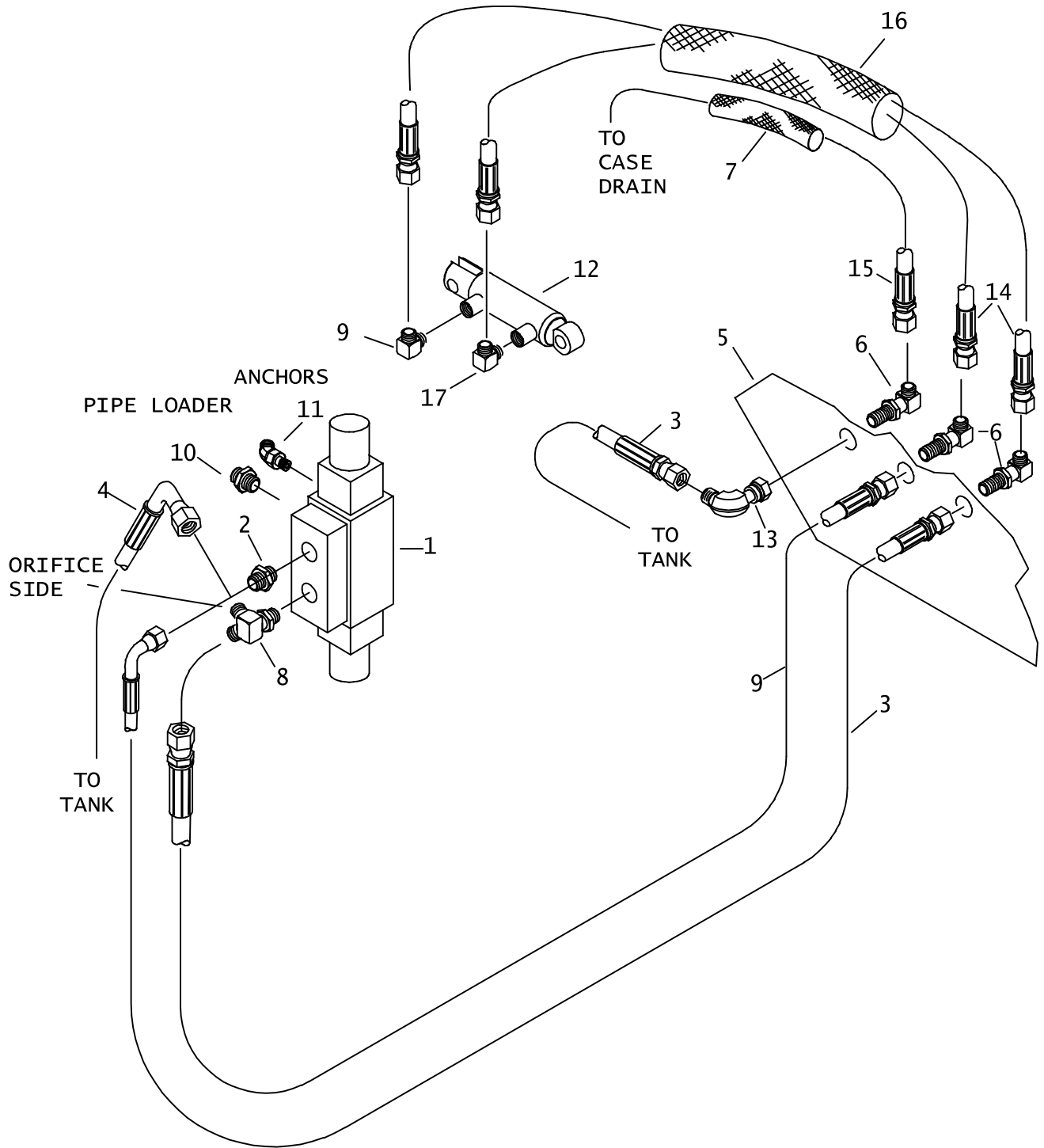

AUXILIARY BACKUP WRENCH HYDRAULICS

REF NO.	PART NUMBER	QTY	DESCRIPTION	REMARKS
1.	516-098	1	SOLENOID VALVE (SINGLE)	
	157-208		O-RING (012 D70)	
	157-209		O-RING (012 D90)	
	157-210		O-RING (018 D70)	
	157-212		O-RING (008 D90)	
	159-505		SOLENOID TUBE	
	217-948		COIL, 12VDC	
2.	154-220	1	CONNECTOR (040-06S)	
3.	154-715	1	HOSE (040FX90S-18"-3000)	
4.	515-041	1	HOSE (040FX90-20"-3000)	
5.	322-612	-	HOSE TRACK STAND	
6.	154-355	3	BK CONNECTOR (040-04090BK)	
7.	117-841	1	ABRASION SLEEVE (1.00" X 164")	
8.	514-431	1	BRANCH TEE (06S-040-040, ORF)	
9.	154-401	1	CONNECTOR (040FX-16"-3000)	
10.	154-246	1	CONNECTOR (06S-080)	
11.	154-283	1	CONNECTOR (06S-08045)	
12.	150-723	1	CYL (1" X 2") W/EYE	
13.	154-255	1	UNION (040-040FX90)	
14.	154-950	2	HOSE (040FX-150"-3000)	
15.	515-161	1	HOSE (040FX-160"-3000)	
16.	117-741	1	ABRASION SLEEVE (1.59" X 145")	
17.	154-252	2	CONNECTOR (04S-04090)	

NOT SHOWN:

FOOTNOTES:

- I. THIS SYSTEM BEGINS WITH S/N 2R0582.

NOTE:

REFER TO O-RING CHART (800-301) IN BACK OF THE BOOK FOR REPLACEMENT OF O-RINGS.

MUD MOTOR HYDRAULICS

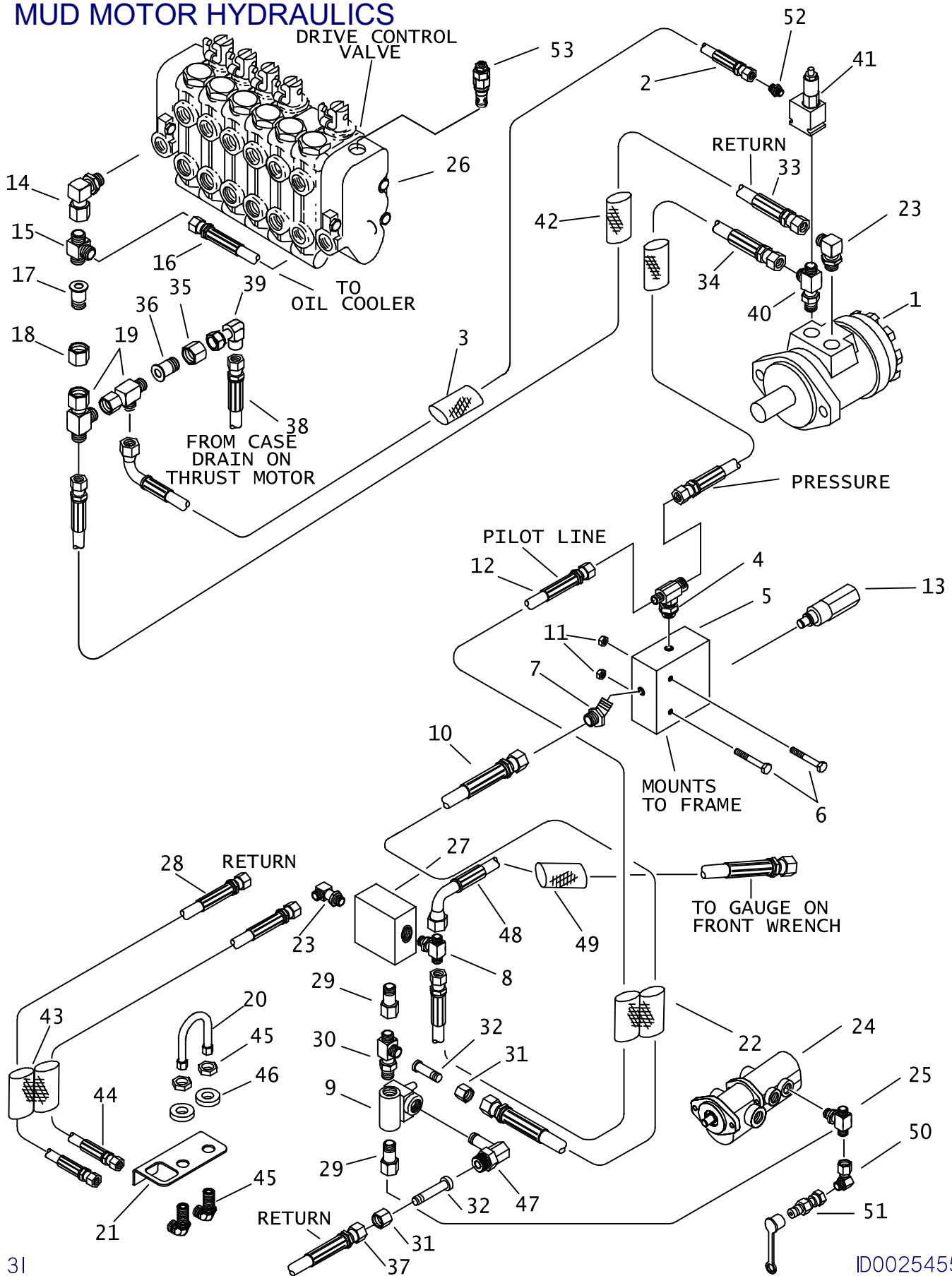

31

ID0025455

MUD MOTOR HYDRAULICS

REF NO.	PART NUMBER	QTY	DESCRIPTION	REMARKS
1.	158-403	-	GEAR MOTOR (3.0 CUI/REV)	EARLY STYLE JT920
	190-725		SEAL REPAIR KIT	
	158-469		GEAR MOTOR(3.0 CUI/REV)	BEGINS WITH S/N 2N2090.USE WITH JT920 & JT921.
2.	154-711	1	HOSE (080FX-30"-3000)	
3.	117-679	3	ABRASION SLEEVE (1.59" X 32")	
4.	156-973	1	BRANCH TEE (080-040-10S)	
5.	157-784	1	PROPORTIONAL HYD FLOW VALVE	USE WITH JT921
	155-748	1	O-RING (916 D90)	
6.	106-602	2	SCREW (M8-1.25 X 80MM)	
7.	154-264	1	CONNECTOR (080-10S45)	
8.	154-293	1	BRANCH TEE (045-040-040)	
9.	153-675	1	HYDRALIC CONTROL VALVE	BEGINS WITH S/N 2V0571
	153-219	-	WH-A RELIEF CARTRIDGE	
10.	154-680	1	HOSE (080FX-74"-3000))	
11.	106-386	2	FLG LOCKNUT (M8-1.25)	
12.	515-170	1	HOSE (040FX-86"-3000))	
13.	217-864	1	COIL (12V)	
14.	154-273	1	CONNECTOR (10S-12090)	
15.	154-368	1	UN RUN TEE (120FX-120-120)	
16.	515-242	1	HOSE (120FX90-95"-3000)	USE WITH JT920 AND JT921
	515-230	1	HOSE (120FX-54"-4000)	USE WITH JT921S
17.	154-249	1	REDUCER STEM (080)	
18.	154-271	1	REDUCER NUT (120F)	
19.	154-266	2	UNION RUN TEE (080FX-080-080)	
20.	156-500	1	HYD LINE (-08)	
21.	353-396	1	DIVIDER PLATE	
22.	115-963	1	ABRASION SLEEVE (1.59" X 75")	
23.	154-322	2	CONNECTOR (080-10S90)	
24.	158-420	1	HYDRAULIC PUMP	
25.	154-318	1	BRANCH TEE (10S-100-100)	
26.	158-937	-	HYDRAULIC CONTROL VALVE (_ SPOOL)	
27.	158-687	1	PRIORITY VALVE	
	190-760	-	SEAL REPAIR KIT	
28.	159-581	1	HOSE (080FX45-114"-3000)	
29.	514-079	2	UNION (10S-100FX)	
30.	154-317	1	RUN TEE (10S-100-100)	
31.	154-310	2	REDUCER NUT (100F)	
32.	154-312	2	REDUCER STEM (080)	
33.	154-711	1	HOSE (08FX-30"-3000)	

NOT SHOWN:

FOOTNOTES:

NOTE:

REFER TO O-RING CHART (800-301) IN BACK OF THE BOOK FOR REPLACEMENT OF O-RINGS.

MUD MOTOR HYDRAULICS

REF NO.	PART NUMBER	QTY	DESCRIPTION	REMARKS
34.	154-708	1	HOSE (080FX-34"-3000)	
35.	154-272	1	REDUCER NUT (080F)	
36.	154-248	1	REDUCER STEM (040)	
37.	154-828	1	HOSE (080FX-17"-3000)	
38.	154-921	1	HOSE (040FX-54"-3000-AR)	WITH TANK
	154-924	1	HOSE (040FX-38"-3000-AR)	WITH OUT TANK
39.	154-255	1	UNION (040-040FX90)	
40.	514-378	1	BRANCH TEE (080-10S-08S)	
41.	158-842	1	RELIEF VALVE (2000PSI)	
	500-756		SEAL REPAIR KIT	
42.	117-679	1	ABRASION SLEEVE (1.59" X 32")	
43.	115-924	1	ABRASION SLEEVE (1.59" X 88")	
44.	154-662	1	HOSE (080FX-98"-3000)	
45.	154-396	2	BK CONNECTOR (08090BK)	
46.	105-460	2	WASHER (13/16")	
47.	154-288	1	CONNECTOR (10S-10090, XL)	
48.	514-968	1	HOSE (040FX90-122"-3000)	
49.	117-713	1	ABRASION SLEEVE (1.00" X 76")	
50.	154-315	1	UNION (100-100FX90)	
51.	159-159	1	QDC ADAPTER (02-100FX)	
52.	154-233	1	CONNECTOR (08S-080)	
53.	150-1064	1	PILOT OPERATED RELIEF (ADJ. 1850 PSI)	BEGINS WITH S/N: 2z1825

NOT SHOWN:

FOOTNOTES:

NOTE:

ANCHOR HYDRAULICS

JT921 & JT921S

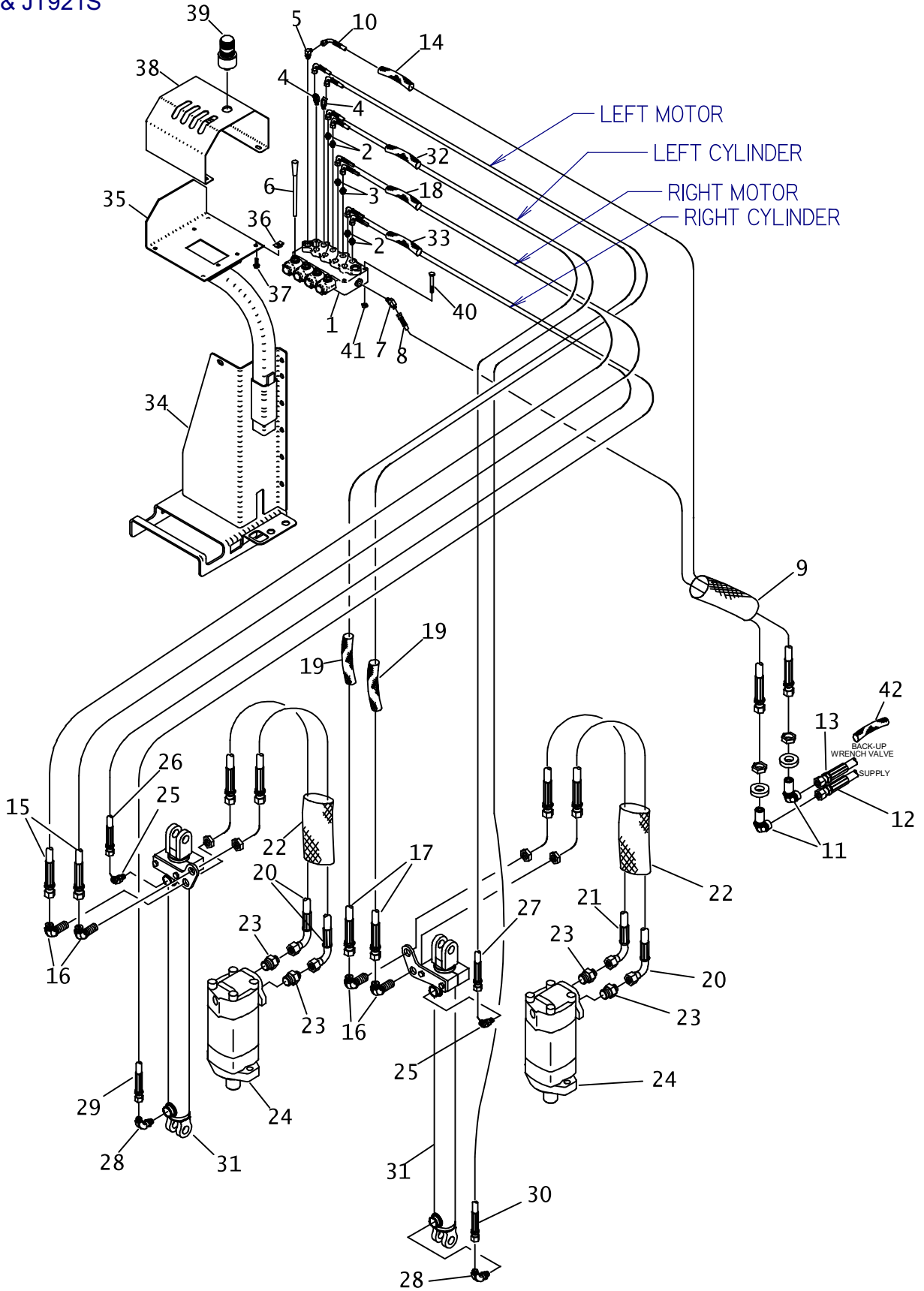

ANCHOR HYDRAULICS

JT921 & JT921S

REF NO.	PART NUMBER	QTY	DESCRIPTION	REMARKS
1.	158-944	1	HYD CONTROL VALVE	
	499-443		VP RELIEF	
	190-641		SEAL REPAIR KIT	
	499-143		LEVER CONTROL & BOOT	
	365-414		M10 THREAD LEVER	
2.	154-220	4	CONNECTOR (040-06S)	
3.	154-221	2	CONNECTOR (06S-060)	
4.	154-224	2	CONNECTOR (06S-06045)	
5.	154-235	1	CONNECTOR (08S-08090)	
6.	500-908	4	LEVER (M8-1.25, BLACK)	
7.	154-284	1	CONNECTOR (08S-08045)	
8.	155-492	1	HOSE (080FX-39"-3000)	
9.	115-925	1	ABRASION SLEEVE (2.38" X 40")	
10.	154-716	1	HOSE (080FX90-48"-3000)	
11.	154-396	2	BK CONNECTOR (080-08090BK)	
12.	154-662	-	HOSE (080FX-98"-3000)	
13.	154-778	-	HOSE (080FX-120"-3000)	
14.	117-566	1	ABRASION SLEEVE (1.25" X 11")	
15.	515-015	2	HOSE (060FX90M-44"-3000)	
16.	154-229	4	BK CONNECTOR (060-06090BK)	
17.	159-843	2	HOSE (060FX90M-34"-3000)	
18.	117-655	1	ABRASION SLEEVE (1.59" X 38")	
19.	117-676	2	ABRASION SLEEVE (1.00" X 30")	
20.	515-707	3	HOSE (060FX90-32"-3000)	
21.	157-822	1	HOSE (060FX90-30"-3000)	
22.	117-679	2	ABRASION SLEEVE (1.59" X 32")	
23.	154-369	4	CONNECTOR (060-10S)	
24.	158-700	-	HYDRAULIC MOTOR	
25.	154-250	2	CONNECTOR (040-06S45)	
26.	154-706	1	HOSE (040FX90S-40"-3000)	SEE FOOTNOTE #2
27.	515-210	1	HOSE (040FX90L-28"-3000)	
28.	154-226	2	CONNECTOR (040-06S90)	

NOT SHOWN:

FOOTNOTES:

1. YOU WILL NEED TO NOTCH SLEEVE TO ALLOW SHORT HOSE TO COME THROUGH.
2. KEYWAY I65-909 COMES WITH THE I58-700 MOTOR.

NOTE:

ANCHOR HYDRAULICS

JT921 & JT921S

REF NO.	PART NUMBER	QTY	DESCRIPTION	REMARKS
29.	154-840	1	HOSE (040FX90S-66"-3000)	
30.	149-064	1	HOSE (040FX90L-54"-3000)	
31.	151-214	-	HYDRAULIC CYLINDER	
32.	117-690	1	ABRASION SLEEVE (1.25" X 58")	SEE FOOTNOTE I
33.	117-691	1	ABRASION SLEEVE (1.25" X 68")	SEE FOOTNOTE I
34.	325-629	-	DRILL FRAME	
35.	350-466	1	VALVE SUPPORT	
36.	106-551	4	CLIP NUT (M8-1.25)	
37.	106-991	4	FLG LK SCREW (M8-1.25 X 20mm)	
38.	350-470	1	COVER	
39.	217-297	1	STROBE LIGHT-GREEN MEDIUM	
40.	106-570	3	SCREW (M8-1.25 X 60mm)	
41.	106-386	3	FLG LOCKNUT (M8-1.25)	
42.	115-924	1	ABRASION SLEEVE (1.59" X 88")	

NOT SHOWN:

FOOTNOTES:

NOTE:

ANCHOR DRIVER HYDRAULICS

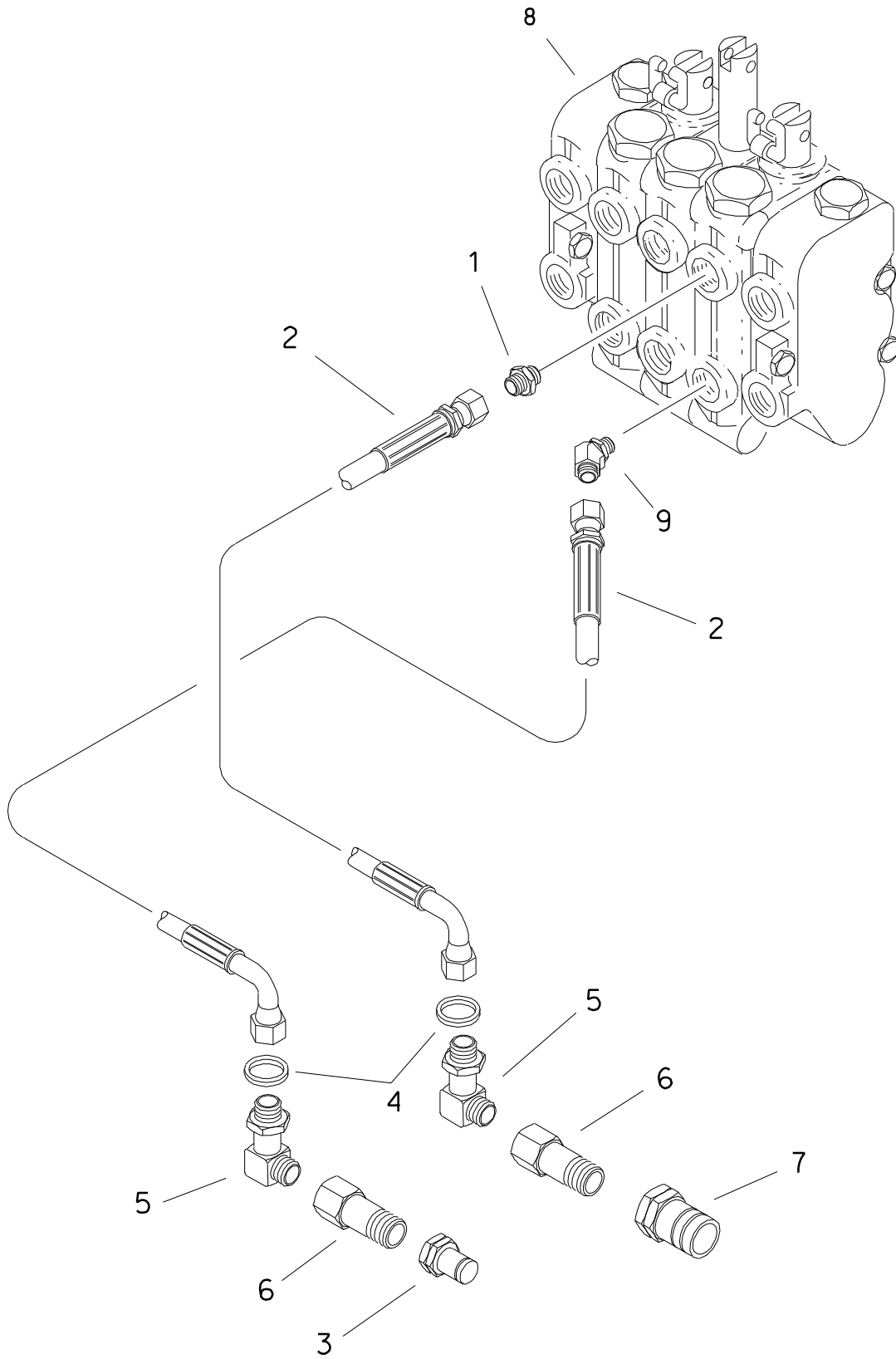

ANCHOR DRIVER HYDRAULICS

REF NO.	PART NUMBER	QTY	DESCRIPTION	REMARKS
1.	154-233	1	CONNECTOR (08S-080)	
2.	154-750	2	HOSE (080FX90-28"-3000)	
3.	159-030	1	QDC ADAPTER (08-08SF)	
4.	105-460	2	WASHER (13/16")	
5.	154-396	2	BK CONNECTOR (080-08090BK)	
6.	156-732	2	CONNECTOR (08J-080)	
7.	159-029	1	QDC BODY (08-08SF)	
8.	516-028	-	HYD CONTROL VALVE (_-SPOOL)	
9.	154-284	1	CONNECTOR (08S-08045)	

FOOTNOTES
REFER TO O-RING CHART (800-301) IN BACK OF THE BOOK FOR REPLACEMENT OF O-RINGS.

HYDRAULIC MOTOR TAPERED KEYED SHAFT 1-1/4"

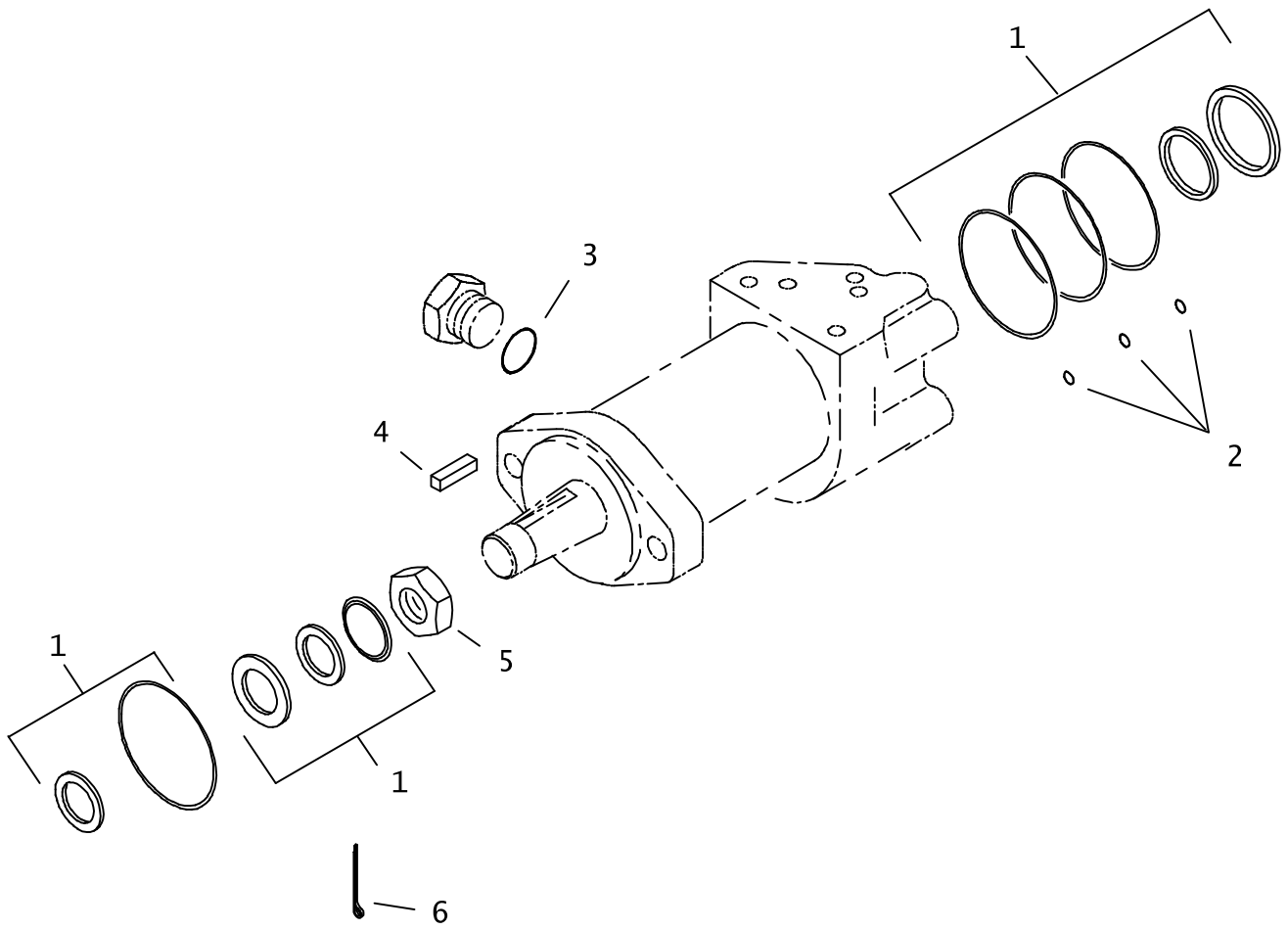

HYDRAULIC MOTOR TAPERED KEYED SHAFT 1-1/4"

REF NO.	PART NUMBER	QTY	DESCRIPTION	REMARKS
	155-579		HYDRAULIC MOTOR	INCL REF NO.'S 1 THRU 6, SEE FOOTNOTES 1 AND 4
	155-580		HYDRAULIC MOTOR	INCL REF NO.'S 1 THRU 5, SEE FOOTNOTES 2 AND 3
	153-280		HYDRAULIC MOTOR	INCL REF NO.'S 1 THRU 5, SEE FOOTNOTE 2
1.	500-347	1	SEAL REPAIR KIT	INCL REF NO.'S 2 AND 3, SEE FOOTNOTE 4
2.	155-771	3	O-RING (011 D70)	
3.	155-760	1	O-RING (904 D90)	
4.	165-915	1	KEY (5/16" X 1")	
5.	105-418	1	LOCKNUT (1-20 NEF)	
6.	105-501	1	COTTER PIN (1/8" X 2")	

NOT SHOWN:

FOOTNOTES:

1. USED ON ROTO WITCH II BORING UNITS.
2. USED ON ROTO WITCH III AND IV BORING UNITS.
3. SHAFT AND BEARING KIT- 500-1469
4. USE SEAL KIT 500-347 FOR MOTOR VERSION 002, 003, 004 & 005. SEAL KIT 500-658 IS TO BE USED WITH VERSION 006 MOTORS.

NOTE:

HYDRAULIC CYLINDERS (2.0" X 1.0")

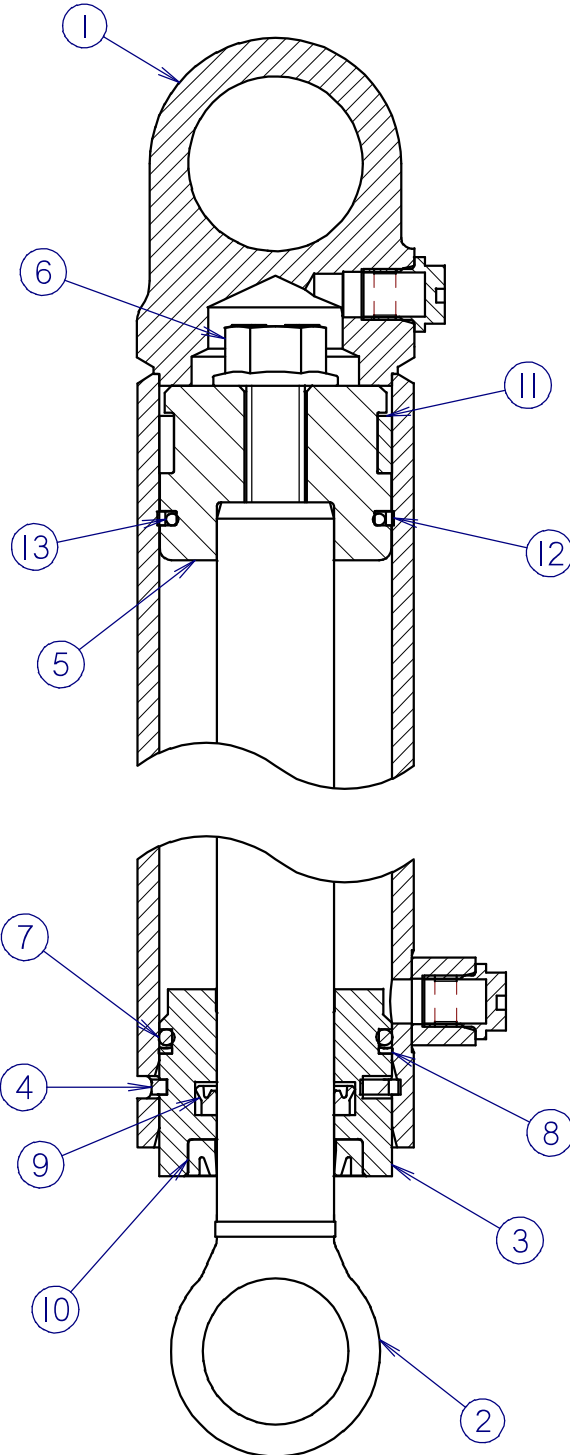

HYDRAULIC CYLINDERS (2.0" X 1.0")

REF NO.	PART NUMBER	QTY	DESCRIPTION	REMARKS
	151-094	-	CYL (2.0 X 1.0 X 2.0)	SEE FOOTNOTES 1 & 2
1	152-029	1	CYLINDER BARREL (2.0 X 2.0)	
2	153-007	1	CYLINDER ROD (1.00 X 2.0)	
	149-667	-	CYL (2.0 X 1.0 X 2.5)	SEE FOOTNOTES 1 & 2
1	149-761	1	CYLINDER BARREL (2.0 X 2.5)	
2	149-728	1	CYLINDER ROD (1.00 X 2.5)	
	151-027	-	CYL (2.0 X 1.0 X 3.0)	SEE FOOTNOTES 1 & 2
1	150-282	1	CYLINDER BARREL (2.0 X 3.0)	
2	150-414	1	CYLINDER ROD (1.00 X 3.0)	
	151-038	-	CYL (2.0 X 1.0 X 4.0)	SEE FOOTNOTES 1 & 2
1	150-290	1	CYLINDER BARREL (2.0 X 4.0)	
2	150-421	1	CYLINDER ROD (1.00 X 4.0)	
	151-039	-	CYL (2.0 X 1.0 X 5.0)	SEE FOOTNOTES 1 & 2
1	150-291	1	CYLINDER BARREL (2.0 X 5.0)	
2	150-422	1	CYLINDER ROD (1.00 X 5.0)	
	151-044	-	CYL (2.0 X 1.0 X 6.0)	SEE FOOTNOTES 1 & 2
1	150-294	1	CYLINDER BARREL (2.0 X 6.0)	
2	150-424	1	CYLINDER ROD (1.00 X 6.0)	
	151-031	-	CYL (2.0 X 1.0 X 8.0)	SEE FOOTNOTES 1 & 2
1	150-285	1	CYLINDER BARREL (2.0 X 8.0)	
2	150-417	1	CYLINDER ROD (1.00 X 8.0)	
	151-076	-	CYL (2.0 X 1.0 X 10.0)	SEE FOOTNOTES 1 & 2
1	152-017	1	CYLINDER BARREL (2.0 X 10.0)	
2	150-444	1	CYLINDER ROD (1.00 X 10.0)	
	149-668	-	CYL (2.0 X 1.0 X 12.0)	SEE FOOTNOTES 1 & 2
1	150-286	1	CYLINDER BARREL (2.0 X 12.0)	
2	149-729	1	CYLINDER ROD (1.00 X 12.0)	
3	150-772	1	CYLINDER HEAD (2.0 X 1.00)	
4	150-778	1	LOCK RING (2.0)	
5	150-775	1	CYLINDER PISTON (2.0 X 1.00)	
6	106-096	1	FLG BOLT (1/2-NC X 1-3/4",GD8)	SEE FOOTNOTE 3
7	157-022	1	O-RING (224 D90)	
8	155-732	1	BACKUP RING (224 D90)	
9	157-540	1	U-SEAL (1.000")	
10	157-537	1	WIPER SEAL (1.000")	
11	125-774	1	WEAR RING	
12	157-534	1	BACKUP RING (131 D90)	
13	157-018	1	O-RING (131 D90)	

NOT SHOWN:

259-100	U-SEAL INSTALLER (1" - 1.499")
259-235	1.00 ROD WIPER TOOL
259-239	WIPER/SEAL INSTALLER (2")
259-241	PISTON INSTALLER (2")
259-188	CYL HEAD SPANNER - TWO PIN

FOOTNOTES:

- REF. #1 & #2 ARE SPECIFIC TO EACH CYLINDER, REF. #3 THRU #13 ARE COMMON FOR ALL THE ABOVE LISTED CYLINDERS
- SEAL REPAIR KIT P/N: 190-165
- APPLY LOCTITE 277 OR EQUIVALENT, TORQUE TO 90-100 FT-LBS

NOTE:

HYDRAULIC CYLINDERS (3.0" X 1.5")

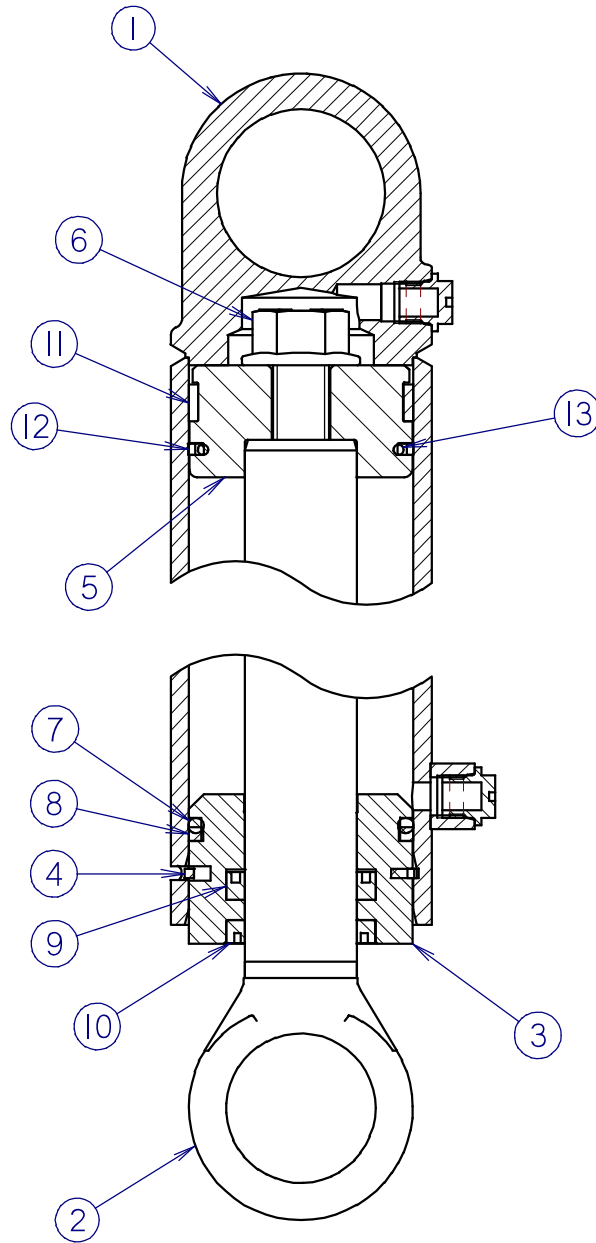

HYDRAULIC CYLINDERS (3.0" X 1.5")

REF NO.	PART NUMBER	QTY	DESCRIPTION	REMARKS
	149-682	-	CYL (3.0 X 1.5 X 2.5)	SEE FOOTNOTES 1 & 2
1	149-804	1	CYLINDER BARREL (3.0 X 2.5)	
2	149-731	1	CYLINDER ROD (1.50 X 2.5)	
	151-049	-	CYL (3.0 X 1.5 X 3.0)	SEE FOOTNOTES 1 & 2
1	150-299	1	CYLINDER BARREL (3.0 X 3.0)	
2	150-431	1	CYLINDER ROD (1.50 X 3.0)	
	151-054	-	CYL (3.0 X 1.5 X 4.0)	SEE FOOTNOTES 1 & 2
1	152-004	1	CYLINDER BARREL (3.0 X 4.0)	
2	150-434	1	CYLINDER ROD (1.50 X 4.0)	
	151-179	-	CYL (3.0 X 1.5 X 5.0)	SEE FOOTNOTES 1 & 2
1	152-068	1	CYLINDER BARREL (3.0 X 5.0)	
2	153-038	1	CYLINDER ROD (1.50 X 5.0)	
	151-086	-	CYL (3.0 X 1.5 X 6.0)	SEE FOOTNOTES 1 & 2
1	152-008	1	CYLINDER BARREL (3.0 X 6.0)	
2	153-003	1	CYLINDER ROD (1.50 X 6.0)	
	151-136	-	CYL (3.0 X 1.5 X 8.0)	SEE FOOTNOTES 1 & 2
1	152-014	1	CYLINDER BARREL (3.0 X 8.0)	
2	153-027	1	CYLINDER ROD (1.50 X 8.0)	
	151-029	-	CYL (3.0 X 1.5 X 10.0)	SEE FOOTNOTES 1 & 2
1	150-284	1	CYLINDER BARREL (3.0 X 10.0)	
2	150-416	1	CYLINDER ROD (1.50 X 10.0)	
	151-043	-	CYL (3.0 X 1.5 X 12.0)	SEE FOOTNOTES 1 & 2
1	150-293	1	CYLINDER BARREL (3.0 X 12.0)	
2	150-426	1	CYLINDER ROD (1.50 X 12.0)	
	151-034	-	CYL (3.0 X 1.5 X 16.0)	SEE FOOTNOTES 1 & 2
1	150-288	1	CYLINDER BARREL (3.0 X 16.0)	
2	150-419	1	CYLINDER ROD (1.50 X 16.0)	
	151-117	-	CYL (3.0 X 1.5 X 20.0)	SEE FOOTNOTES 1 & 2
1	152-054	1	CYLINDER BARREL (3.0 X 20.0)	
2	150-669	1	CYLINDER ROD (1.50 X 20.0)	
3	150-774	1	CYLINDER HEAD (3.0 X 1.50)	
4	150-911	1	LOCK RING (3.0)	
5	150-777	1	CYLINDER PISTON (3.0 X 1.50)	
6	106-098	1	FLG BOLT (3/4-NC X 2", GD8)	SEE FOOTNOTE 3
7	155-734	1	O-RING (334 D90)	
8	155-733	1	BACKUP RING (334 D90)	
9	157-542	1	U-SEAL (1.500")	
10	157-539	1	WIPER SEAL (1.500")	
11	125-776	1	WEAR RING	
12	157-536	1	BACKUP RING (230 D90)	
13	157-020	1	O-RING (230 D90)	

NOT SHOWN:

259-040	U-SEAL INSTALLER (1.5" - UP)
259-237	ROD WIPER INSTALLER (1.5")
259-065	PISTON SEAL INSTALLER (3")
259-066	PISTON INSTALLER (3")
259-188	CYL HEAD SPANNER - TWO PIN

FOOTNOTES:

- REF. #1 & #2 ARE SPECIFIC TO EACH CYLINDER, REF. #3 THRU #13 ARE COMMON FOR ALL THE ABOVE LISTED CYLINDERS.
- SEAL REPAIR KIT P/N: 190-167
- APPLY LOCTITE 277 OR EQUIVALENT, TORQUE TO 290-325 FT-LBS

NOTE:

NOTES:

ELECTRICAL

ELECTRICAL SCHEMATIC

JT921 w/AUTOBORE SHUTOFF BEGINS w/2Z0259

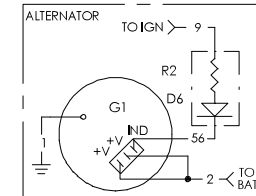
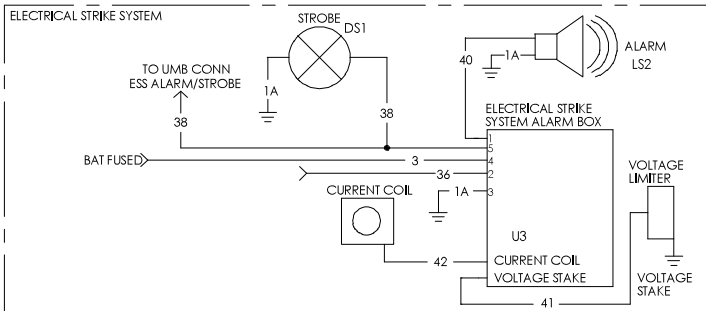
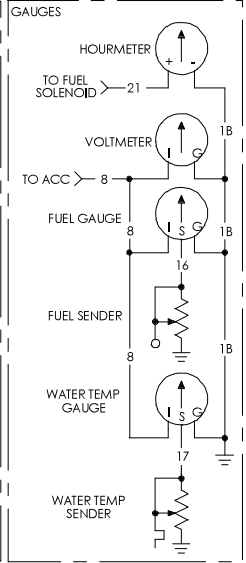
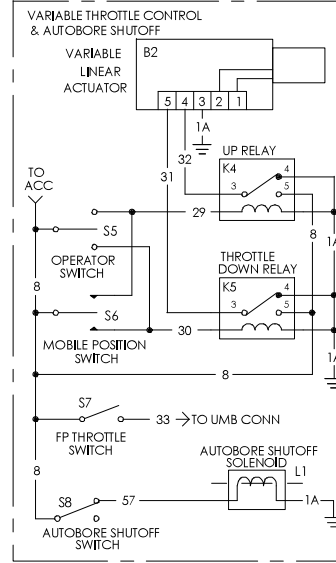
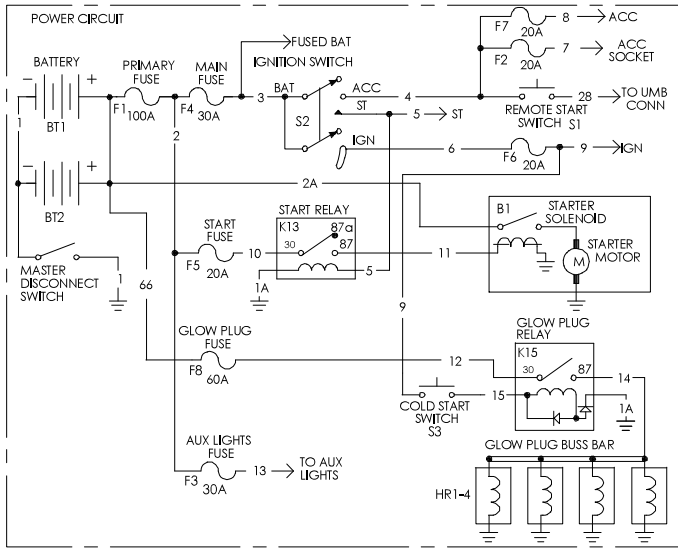

UMBILICAL CONNECTION

TO	UMBILICAL CABLE PIN #
TO REMOTE START SWITCH	28 → 7
TO FLUID ADJUST POT "A"	53 → 10
TO FLUID ADJUST POT "B"	52 → 9
TO FLUID SWITCH "MAX"	51 → 6
TO "ESS ALARM/STROBE"	38 → 14
TO "PP THROTTLE"	33 → 8
TO "ENGINE STOP SWITCH"	18 → 4
	1A → 1

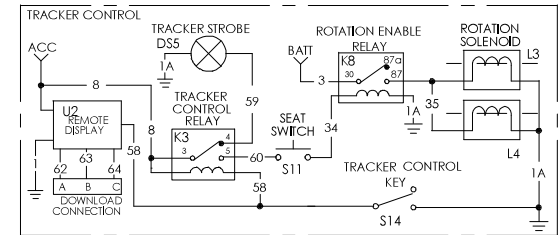
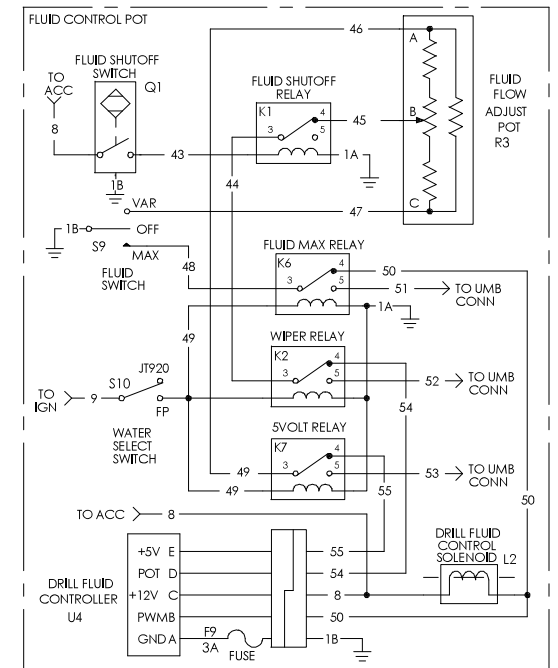
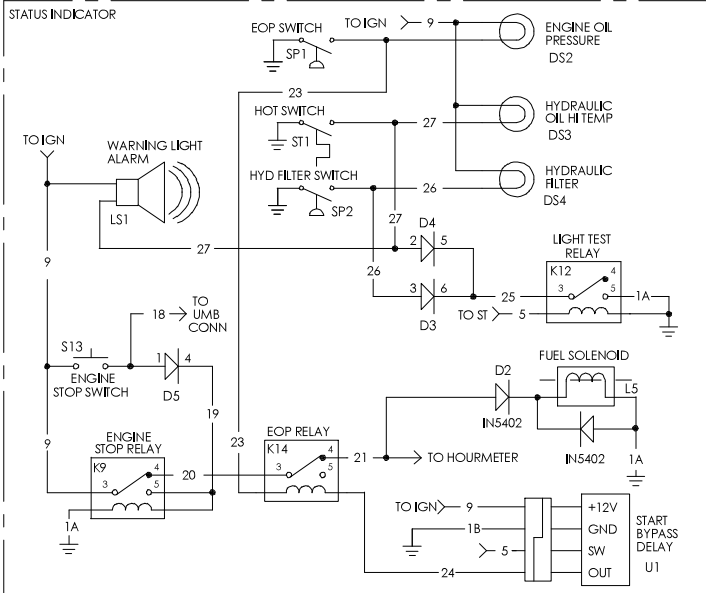

ELECTRICAL SCHEMATIC

JT921 w/AUTOBORE SHUTOFF BEGINS w/2Z0259

COMPONENT DESCRIPTIONS

Ref. No.	Part No.	Component	Notes
B1		STARTER	INCLUDES SOLENOID
B2	215-231	VARIABLE LINEAR ACTUATOR	CMW# 215-231
BT1	213-104	BATTERY	12V,875CCA
BT2		BATTERY	
D1		DIODE	1N5402
D2		DIODE	1N5402
D3		DIODE	
D4		DIODE	
D5		DIODE	
D6		DIODE	
DS1	217-296	ESID STROBE	AMBER
DS2		ENGINE OIL PRESSURE	
DS3		HYDRAULIC OIL HI TEMPATURE	
DS4		HYDRAULIC FILTER	
DS5	217-297	TRACKER CONTROLLER STROBE	GREEN
F1	211-311	PRIMARY FUSE	100A
F4	211-295	MAIN FUSE	30A
F7		ACC FUSE	20A
F2		ACC SOCKET	20A
F6	211-293	IGNITION FUSE	20A
F5	211-293	STATRER FUSE	20A
F8	211-310	GLOW PLUG FUSE	60A
F3	211-295	AUX LIGHTS FUSE	30A
F9	211-289	DRILL FLUID CONTROLLER FUSE	3A
G1	215-189	ALTERNATOR	12V, 60A
HR1		GLOW PLUG	
HR2		GLOW PLUG	
HR3		GLOW PLUG	
HR4		GLOW PLUG	
K1	211-296	FLUID SHUTOFF RELAY	
K2	211-296	WIPERE RELAY	
K3	211-296	TRACKER CONTROL RELAY	
K4	211-296	UP RELAY	
K5	211-296	THROTTLE DOWN RELAY	
K6	211-296	FLUID MAX RELAY	
K7	211-296	5V RELAY	
K8	211-298	ROTATION ENABLE RELAY	
K9	211-296	ENGINE STOP RELAY	
K12	211-297	LIGHT TEST RELAY	
K13	211-298	STARTER RELAY	
K14	211-296	EOP RELAY	
K15	217-701	GLOW PLUG RELAY	

ELECTRICAL SCHEMATIC
 JT921 w/AUTOBORE SHUTOFF BEGINS w/2Z0259

COMPONENT DESCRIPTIONS			
L1		AUTOBORE SHUTOFF SOLENOID	
L2		DRILL FLUID CONTROL SOLENOID	
L3		ROTATION SOLENOID	
L4		ROTATION SOLENOID	
L5		FUEL SOLENOID	
L6		WRENCH UP SOLENOID	
L7		WRENCH DOWN SOLENOID	
LS1		WARNING LIGHT ALARM	
LS2	306-602	ESID ALARM	
M1	215-128	HOURLMETER	
M2	215-133	FUEL GAUGE	
M3		WATER TEMP GAUGE	
M4		VOLT METER	
Q1		FLUID SHUTOFF SWITCH	
Q2			
R1		ENGINE WATER TEMERTURE SENDER	
R2	214-449	ALTERNATOR DIODE RESISTOR	
R3	217-940	FLIUD FLOW ADJUST POTENTIONMETER	
R4	217-549	FUEL LEVEL SENDER	
S1		REMOTE START SWITCH	
S2	214-852	IGNITION SWITCH	
S3		COLD START SWITCH	
S4	217-849	MASTER DISCONNECT SWITCH	
S5	214-647	OPERATOR SWITCH	
S6		MOBILE POSITION SWITCH	
S7	217-762	FP THROTTLE SWITCH	
S8		AUTOBORE SHUTOFF SWITCH	
S9	214-467	FLUID SWITCH	
S10		WATER SELECT SWITCH	
S11	217-935	SEAT SWITCH (OPERATOR PRESENCE)	WITH 215-939 HARNESS
S12		AUXILLARY WRENCH SWITCH UP/DOWN	
S13		ENGINE STOP SWITCH	
S14		TRACKER CONTROL KEY	
SP1		EOP SWITCH	SP1/217-721 OIL PRESSURE SWITC
SP2	see notes	HYD. FILTER SWITCH	component of 157-458
ST1	214-854	HOT SWITCH	
U1	217-937	START BYPASS DELAY	
U2	SUBSITE	REMOTE DISPLAY	
U3	220-1024	ESID MODULE	
U4		DRILL FLUID CONTROLLER	

ELECTRICAL SCHEMATIC

JT921 w/AUTOBORE SHUTOFF BEGINS w/2Z0259

CIRCUIT DESCRIPTIONS

Circuit Number	Wire Color	Function
1	blk	System Ground
1A	blk/red	Medium Ground
1B	blk/blu	Low Ground
2	red	Battery Positive (100 Amp Primary Power Fuse)
2A	red	Fused Alternator (Battery to starter)Un-fused
3	red/blu	Individually Fused Battery Circuit
4	org/blu	Accessory circuit
5	wht/blk	Start Circuit
6	org/blu	Ignition Circuit
7	org/yel	Fused Accessory Socket Circuit
8	org	Fused Accessory Circuit
9	org/grn	Ignition Circuit
10	pur/blk	Fused Start Circuit
11	pur	Start Relay to Starter Solenoid
12	gra	Fused Glow Plug Circuit
13	yel	Fused Auxiliary Light Connector
14	gra	Glow Plug Relay to Glow Plugs
15	pur/wht	Glow Plug Switch to Glow Plug Relay
16	brn	Fuel Sender to Fuel Gauge
17	grn	Water Temperature Sender to Water Temperature Gauge
18	yel/red	Engine Stop Switch to Diode Anode & Umbilical Connector
19	yel/gra	Diode Cathode to Engine Stop Relay
20	blu	Engine Stop Relay to Engine Oil Pressure Relay
21	org/gra	Engine Oil Pressure Relay to Diode Anode & Hourmeter
22	org/blk	Diode Cathode to Fuel Shutoff Solenoid
23	wht/blu	Engine Oil Pressure Switch toEOP Relay & EOP Indicator
24	wht/org	Start Bypass Delay to EOP Relay
25	blk/yel	Light Test Relay toDiode Cathodes
26	gra/yel	Hydraulic Fliter Switch to Diode Anode & Hydraulic Filter Light
27	gra/blk	Hydraulic Oil Temperature Switch to Doide Anode & Hot light
28	red/blk	Remote Start Switch to Umbilical Connector
29	pur/org	Throttle Switches toThrottle Up Relay
30	blu/org	Throttle Switches toThrottle Down Relay
31	gm/org	Throttle Down Relay to Linear Actuator
32	wht/org	Throttle Up Relay to Linear Actuator
33	yel/blk	FP Throttle Switch to Umbilical Connector
34	gra/grn	Seat Switch to Rotation Enable relay
35	gra/red	Rotation Enable Relay to Rotation Solenoids

ELECTRICAL SCHEMATIC
 JT921 w/AUTOBORE SHUTOFF BEGINS w/2Z0259

CIRCUIT DESCRIPTIONS		
Circuit Number	Wire Color	Function
36	red/yel	ESID module to Delay Timer, Strobe Relay, Shutdown Relay & Diode
37	tan/blk	delay Timer to Shutdown Relay
38	wht/pur	ESID module to Strobe Relay, Delay Timer & Umbilical Connector
39	wht/yel	Strobe Relay to Strobe
40	wht/grn	ESID Module to Alarm
41	*****	Voltage Limiter Cable
42	*****	Current Transformer Cable
43	wht	Fluid Shutoff Switch to Fluid Relay
44	grn	Fluid Shutoff Relay to Wiper Relay
45	grn/blu	Fluid Flow Adjust Potentiometer To Fluid Shutoff Relay
46	blu/grn	Fluid Flow Adjust Potentiometer 5V
47	blk/yel	Fluid Switch to Fluid Flow Adjust Potentiometer
48	blk/wht	Fluid Switch to Fluid Max Relay
49	yel/blu	Water Select Switch to wiper Relay, Fluid Max Relay, & 5V Relay
50	blk/wht	Fluid Max Relay to Drill Fluid Solenoid & Drill Fluid Controller
51	blu/wht	Fluid Max Relay to Umbilical Connector
52	gra/grn	Wiper Relay to Umbilical Connector
53	gra/blu	5v Relay to Umbilical Connector
54	tan/grn	Wiper Relay to Drill Fluid Controller
55	tan/blu	5v Relay to Drill Fluid Controller
56	org/blu	Diode Pack to Alternator Exciter Circuit
57	yel/blk	Autobore Switch to Autobore Solenoid
58	tan/red	Tracker Control Switch to Remote Display & Tracker Control Relay
59	gra/pur	Tracker Control Relay to Strobe
60	tan/pur	Tracker Control Relay to Seat Switch
61	blk	Remote Display to Download Connector "A"
62	wht	Remote Display to Download Connector "B"
63	yel	Remote Display to Download Connector "C"
64	yel/grn	Auxillary Wrench Switch to Aux. Wrench Up Solenoid
65	pur/grn	Auxillary Wrench Switch to Aux. Wrench Down Solenoid
66	red	Primary Power & Glow Plug Fuse Supply Power

WIRING HARNESSSES			
Ref. No.	Part No.	Quantity	Description
1	215-1177	1	JT922 ENGINE FRAME HARNESS
2	215-1178	1	JT922 DRILL FRAME HARNESS
3	215-1164	1	DUAL ELEMENT COLD START HARNESS
4	215-310	1	BATTERY CABLE (RED)
5	215-1029	1	BATTERY CABLE (BLACK)
6	215-1035	1	BATTERY CABLE (BLACK)
7	213-002	1	BATTERY CABLE (BLACK)
8	215-333	1	BATTERY CABLE (RED)
9	215-1566	1	HOME SWITCH HARNESS

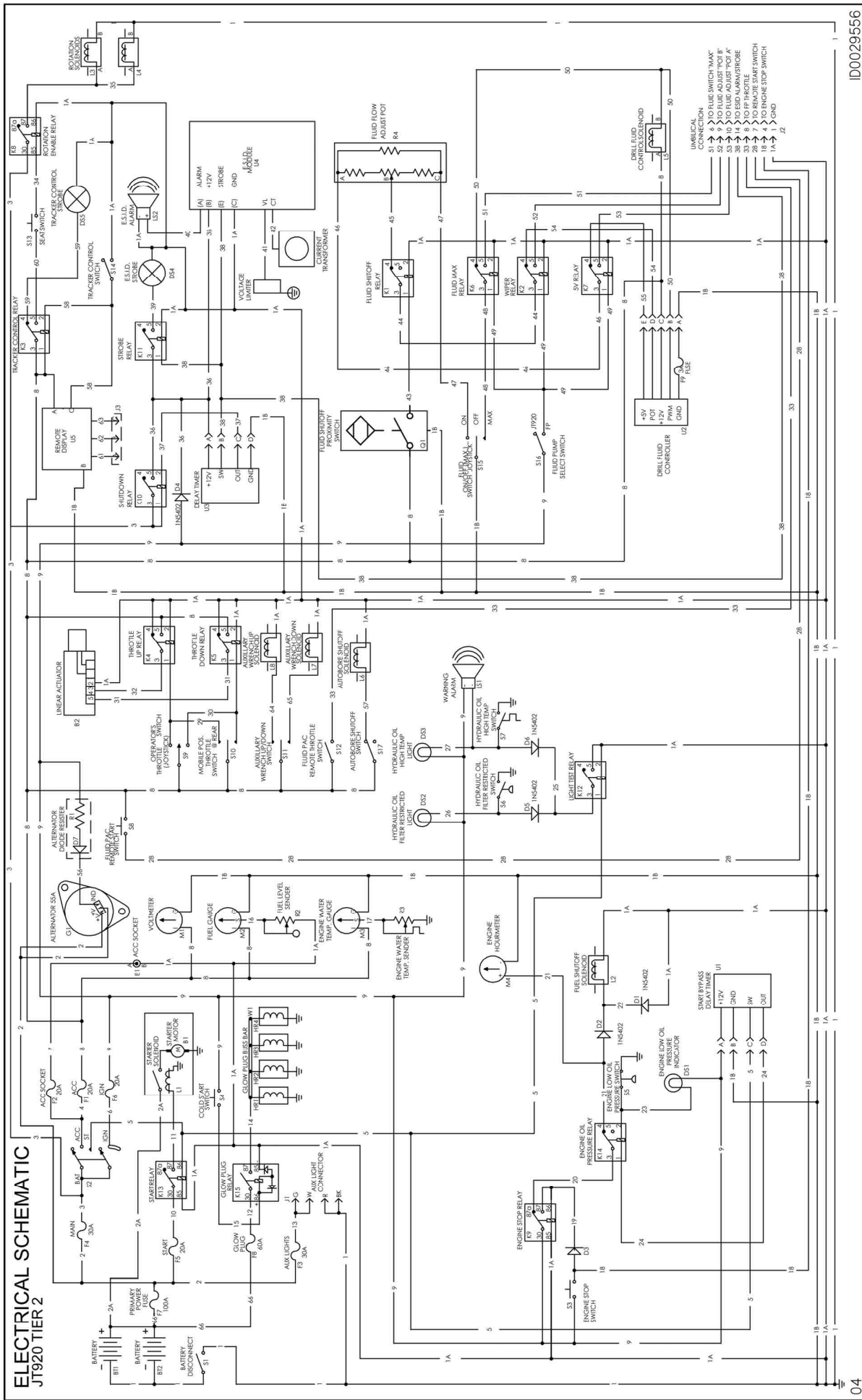

ID0029556

04

ELECTRICAL SCHEMATIC

JT920 TIER 2

REF. #		COMPONENT	NOTES
B1		Starter motor	
B2	215-231	Linear actuator	CMW# 215-231
BT1		Battery	12V
BT2		Battery	Dual battery option
D1-D7		Diodes	1N5402
DS1		Engine low oil pressure indicator	
DS2		Hydraulic oil filter restricted light	
DS3		Hydraulic oil high temperature light	
DS4		E.S.I.D. Strobe light	
DS5		Tracker control strobe	
E1		Acc socket	
F1	211-293	Accessory fuse	20A Mini-ATC
F2		Accessory socket fuse	
F3	211-295	Auxillary light fuse	30A Mini-ATC
F4	211-295	Main fuse	30A Mini-ATC
F5	211-293	Start fuse	20A Mini-ATC
F6		Ignition fuse	
F7	211-311	Primary Power Fuse	100A BK/AMI
F8	211-310	Glow plug fuse	60A BK/AMI
F9		Drill fluid controller fuse	3A ATC
G1		Alternator	55A 12V
HR1		Glow plug	
HR2		Glow plug	
HR3		Glow plug	
HR4		Glow plug	
J1		Auxillary light connector	
J2		Umbilical connector	
J3		Download connector	
K1	211-296	Fluid shutoff relay	Bussmann Component (Micro)
K2		Wiper relay	
K3		Tracker control relay	
K4		Throttle up relay	
K5		Throttle down relay	
K6		Fluid max relay	
K7		5V relay	
K8	211-298	Rotation enable relay	Bussmann Component (Mini)
K9	211-296	Engine stop relay	Bussmann Component (Micro)
K10	211-297	Shutdown relay	Bussmann Component (4-Pin Micro)
K11		Strobe relay	
K12		Light test relay	
K13	211-298	Start relay	Bussmann Component (Mini)
K14	211-296	Engine oil pressure relay	Bussmann Component (Micro)
K15	217-701	Glow plug relay	(60 AMP, SPST 12V DC

ELECTRICAL SCHEMATIC

JT920 TIER 2

REF. #	Part #	COMPONENT	NOTES
L1		Starter solenoid	
L2		Fuel shutoff solenoid	
L3		Rotation solenoid	
L4		Rotation solenoid	
L5		Drill fluid control solenoid	
L6		Autobore shutoff solenoid	
L7		Aux. Wrench down solenoid	
L8		Aux. Wrench up solenoid	
LS1		Warning alarm (status)	
LS2	306-602	ESID alarm	
M1		Voltmeter	
M2	215-133	Fuel gauge	
M3		Engine Water temperature gauge	
M4	215-128	Engine Hourmeter	
Q1		Fluid shutoff proximity switch	
R1	214-449	Alternator Diode Resistor	
R2	217-549	Fuel level sender	
R3		Engine water temperature sender	
R4	217-940	Fluid flow adjust potentiometer	
S1		Battery disconnect switch	
S2		Ignition switch	
S3		Engine stop switch	
S4		Cold start switch	
S5	217-736	Engine low oil pressure switch	
S6		Hydraulic oil filter restricted switch	
S7		Hydraulic oil high temperature switch	
S8	306-607	Fluid Pac Remote start switch	With 306-608 cover
S9	214-467	Operator's Throttle Switch "Joystick"	
S10		Mobile Position Throttle Switch @ Rear	
S11		Aux. Wrench up/down switch	
S12	217-762	Fluid Pac remote throttle switch	
S13	217-935	Seat switch (Operator Presence)	With 215-939 harness
S14		Tracker control switch	
S15	214-466	Fluid on-off-(maximum) switch "Joystick"	
S16		Fluid Pump select switch	
S17		Autobore shutoff switch	
U1	217-937	Start Bypass Delay Timer	
U2	215-914	Drill fluid controller	
U3	214-502	Delay timer (1min)	
U4	217-232	ESID module	
U5		Remote display	
W1		Glow plug buss bar	

ELECTRICAL SCHEMATIC

JT920 TIER 2

CIRCUIT NUMBER	WIRE COLOR	FUNCTION
1	blk	High current ground
1A	blk/red	Medium current ground
1B	blk/blu	Low current ground
2	red	Protected Battery circuit (100 amp primary power fuse)
2A	red	Battery cable (Battery to starter motor) un-fused
3	red/blu	Individually Fused battery circuit
4	org/brn	Accessory circuit
5	wht/blk	Start circuit
6	org/blu	Ignition circuit
7	org/yel	Fused accessory socket circuit
8	org	Fused accessory circuit
9	org/grn	Fused ignition circuit
10	pur/blk	Fused start circuit
11	pur	Start relay to starter solenoid
12	gra	Fused glow plug circuit
13	yel	Fused auxillary light connector
14	gra	Glow plug relay to glow plugs
15	pur/wht	Glow plug switch to glow plug relay
16	brn	Fuel sender to fuel gauge
17	grn	Water temperature sender to water temperature gauge
18	yel/red	Engine stop switch to diode anode & umbilical connector
19	yel/gra	Diode cathode to engine stop relay
20	blu	Engine stop relay to engine oil pressure relay
21	org/gra	Engine oil pressure relay to diode anode & hourmeter
22	org/blk	Diode cathodes to fuel shutoff solenoid
23	wht/blu	Engine oil pressure switch to EOP relay & EOP indicator
24	wht/org	Start bypass delay to EOP relay
25	blk/yel	Light test relay to diode cathodes
26	gra/yel	Hydraulic filter switch to diode anode & hydraulic filter light
27	gra/blk	Hydraulic oil temperature switch to diode anode & HOT light
28	red/blk	Remote start switch to umbilical connector
29	pur/org	Throttle switches to throttle up relay
30	blu/org	Throttle switches to throttle down relay
31	grn/org	Throttle down relay to linear actuator
32	wht/org	Throttle up relay to linear actuator
33	yel/blk	FP throttle switch to umbilical connector

ELECTRICAL SCHEMATIC

JT920 TIER 2

CIRCUIT NUMBER	WIRE COLOR	FUNCTION
34	gra/grn	Seat switch to rotation enable relay
35	gra/red	Rotation enable relay to rotation solenoids
36	red/yel	ESID module to delay timer, strobe relay, shutdown relay, & diode
37	tan/blk	Delay timer to shutdown relay
38	wht/pur	ESID module to strobe relay, delay timer, & umbilical connector
39	wht/yel	Strobe relay to strobe
40	wht/grn	ESID module to alarm
41	*****	Voltage limiter cable
42	*****	Current transformer cable
43	wht	Fluid shutoff switch to fluid shutoff relay
44	grn	Fluid shutoff relay to wiper relay
45	grn/blu	Fluid flow adjust potentiometer to fluid shutoff relay
46	blu/grn	Fluid flow adjust potentiometer 5V
47	blk/yel	Fluid switch to fluid flow adjust potentiometer
48	blk/wht	Fluid switch to fluid max relay
49	yel/blu	Water select switch to wiper relay, fluid max relay, & 5V relay
50	blk/wht	Fluid max relay to drill fluid solenoid & drill fluid controller
51	blu/wht	Fluid max relay to umbilical connector
52	gra/grn	Wiper relay to umbilical connector
53	gra/blu	5V relay to umbilical connector
54	tan/grn	Wiper relay to drill fluid controller
55	tan/blu	5V relay to drill fluid controller
56	org/blu	Diode pack to alternator exciter circuit
57	yel/blk	Autobore switch to autobore solenoid
58	tan/red	Tracker control switch to remote display & Tracker control relay
59	gra/pur	Tracker control relay to strobe
60	tan/pur	Tracker control relay to seat switch
61	blk	Remote display to download connector "A"
62	wht	Remote display to download connector "B"
63	yel	Remote display to download connector "C"
64	yel/grn	Auxillary wrench switch to Aux. Wrench up solenoid
65	pur/grn	Auxillary wrench switch to Aux. Wrench down solenoid
66	red/grn	Primary power & glow plug fuse supply power

ELECTRICAL SCHEMATIC

JT920 TIER 2

Ref. No.	Part No.	Qty.	Description
1	214-175	1	STROBE PIGTAIL HARNESS
2	214-293	1	GAUGE HARNESS
3	214-295	1	RELAY HARNESS
4	214-296	1	BORING CONSOLE HARNESS
5	215-939	1	SEAT SWITCH HARNESS
6	213-171	1	ENGINE FRAME HARNESS old # 214-294

ELECTRICAL DIAGRAM

GAUGE HARNESS W/AUTOBORE SELECT

JT920 / JT920C / JT920L / JT921

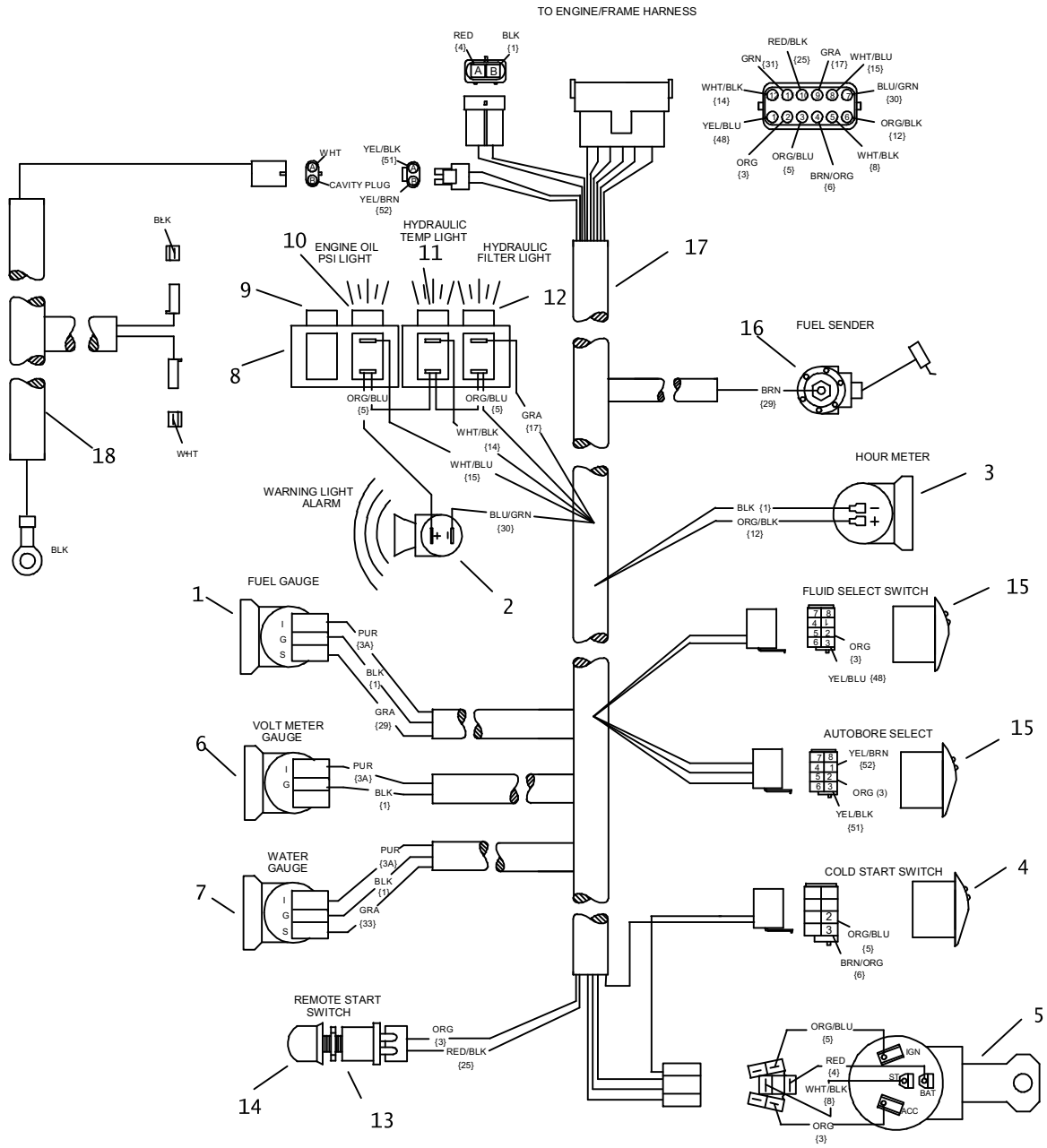

ELECTRICAL DIAGRAM

GAUGE HARNESS W/AUTOBORE SELECT

JT920 / JT920C / JT920L / JT921

REF NO.	PART NUMBER	QTY	DESCRIPTION	REMARKS
1.	215-133	1	FUEL GAUGE	
	215-415	1	NITE-LIGHT KIT (12V DC)	
2.	306-603	1	AUDIO ALARM	
3.	215-128	1	HOUR METER	
4.	217-789	1	ROCKER SWITCH	OFF-MOMENTARY ON
	165-817	1	SWITCH GASKET	
5.	214-852	1	IGNITION SWITCH	
	214-961		KEY, PAIR	
	214-962		SWITCH MOUNTING NUT	
6.	215-129	1	VOLT METER	
	215-415	1	NITE-LIGHT KIT (12V DC)	
7.	217-512	1	WATER TEMPERATURE GAUGE	
	215-415	1	NITE-LIGHT KIT (12V DC)	
8.	217-020	2	PILOT LIGHT	
	217-046	1	BULB (12V DC)	
9.	217-028	1	INSERT (BLK) BLANK	
10.	217-021	1	INSERT (RED) ENG OIL PSI	
11.	217-027	1	INSERT (RED) HYD OIL HI TEMP	
12.	217-036	1	INSERT (YEL) HYD OIL PSI	
13.	306-607	1	HORN BUTTON	
14.	306-608	1	BUTTON COVER	
15.	217-762	2	ROCKER SWITCH (SPDT)	ON-ON
	165-817	2	SWITCH GASKET	
16.	217-549	-	FUEL SENDER	
17.	214-293	1	GAUGE HARNESS	
18.	214-495	1	AUTO BORE JUMPER	

NOT SHOWN:

FOOTNOTES:

NOTE:

ALL CONNECTORS ARE SHOWN WITH REAR VIEWS

ELECTRICAL DIAGRAM

JT921, JT921S,
JT921P, JT92SP

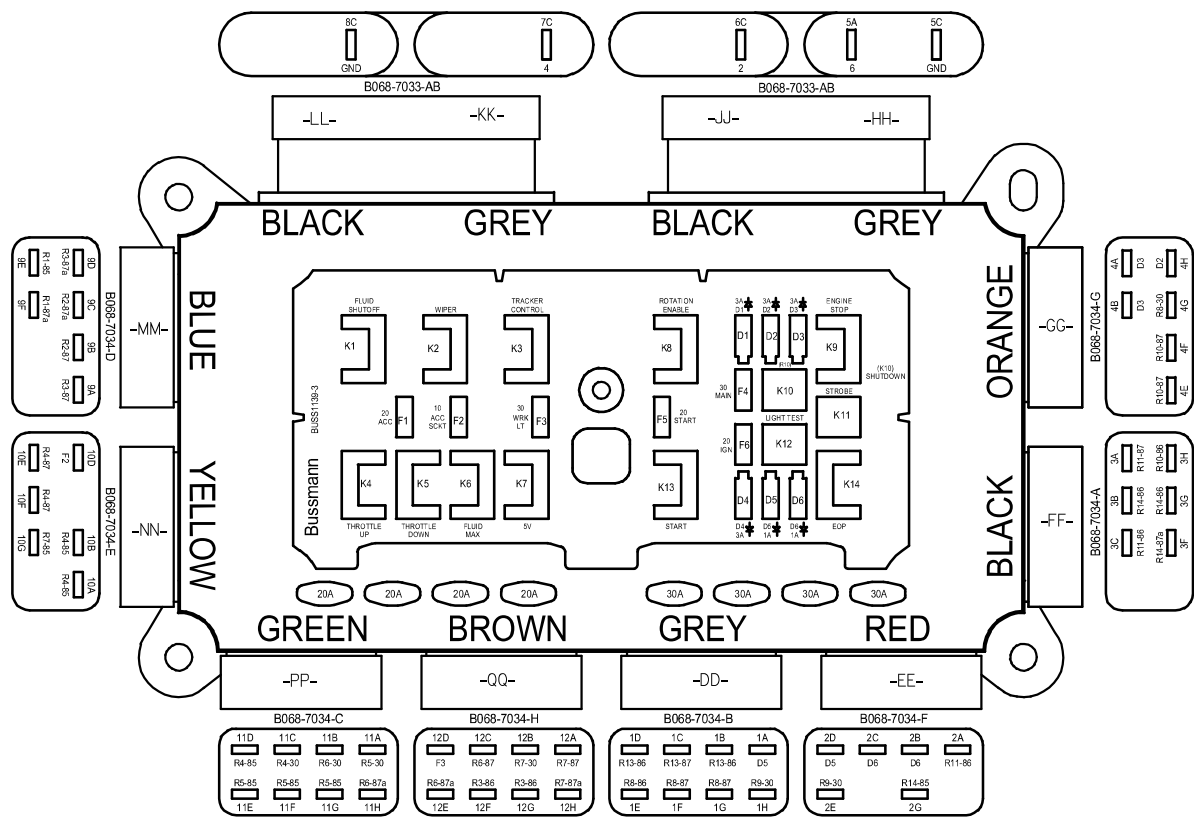

ENGINE/FRAME HARNESS

JT921, JT921S,
JT921P, JT921SP

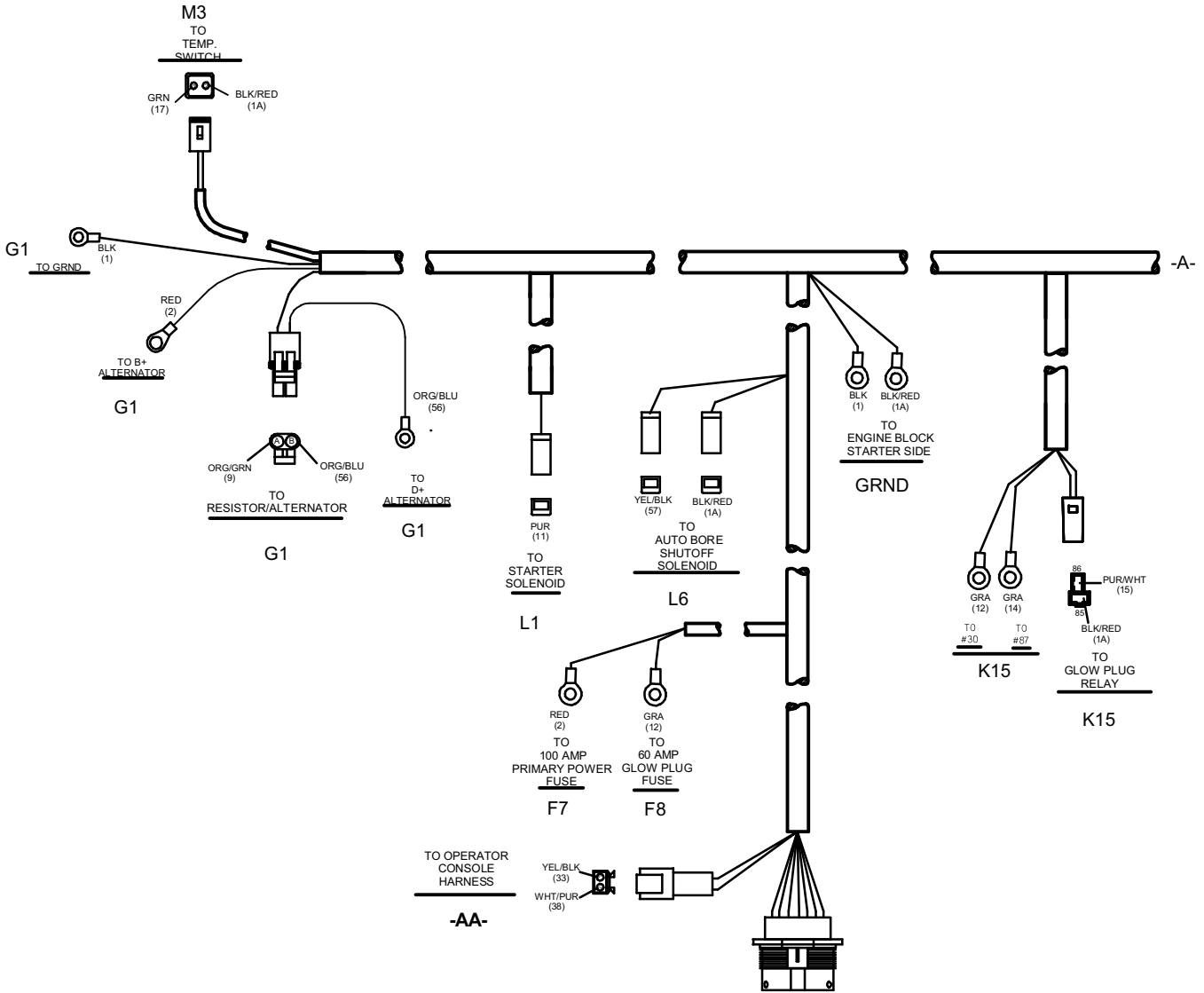

TO GAUGE BUSS HARNESS			
PIN #	WIRE COLOR & CIRCUIT	PIN #	WIRE COLOR & CIRCUIT
A	YEL/BLK (57)	M	WHT/BLU (23)
B	BLK (1)	N	PUR/ORG (29)
C	GRN (17)	P	BLU/ORG (30)
D	PUR (11)	R	GRN/ORG (31)
E	ORG (8)	S	WHT/ORG (32)
F	ORG/GRN (9)	T	WHT/YEL (39)
G	BLK/RED (1A)	U	BLK/WHT (50)
H	PUR/WHT (15)	V	BLU/WHT (51)
J	YEL/RED (18)	W	GRA/GRN (52)
K	ORG/BLK (22)	X	GRA/BLU (53)
L	RED/BLK (28)		

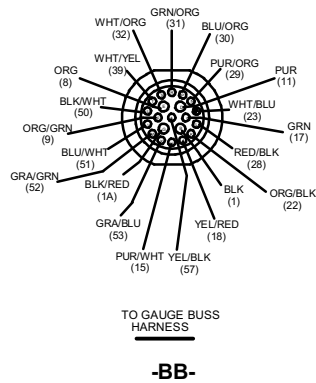

ENGINE/FRAME HARNESS

JT921, JT921S,
JT921P, JT921SP

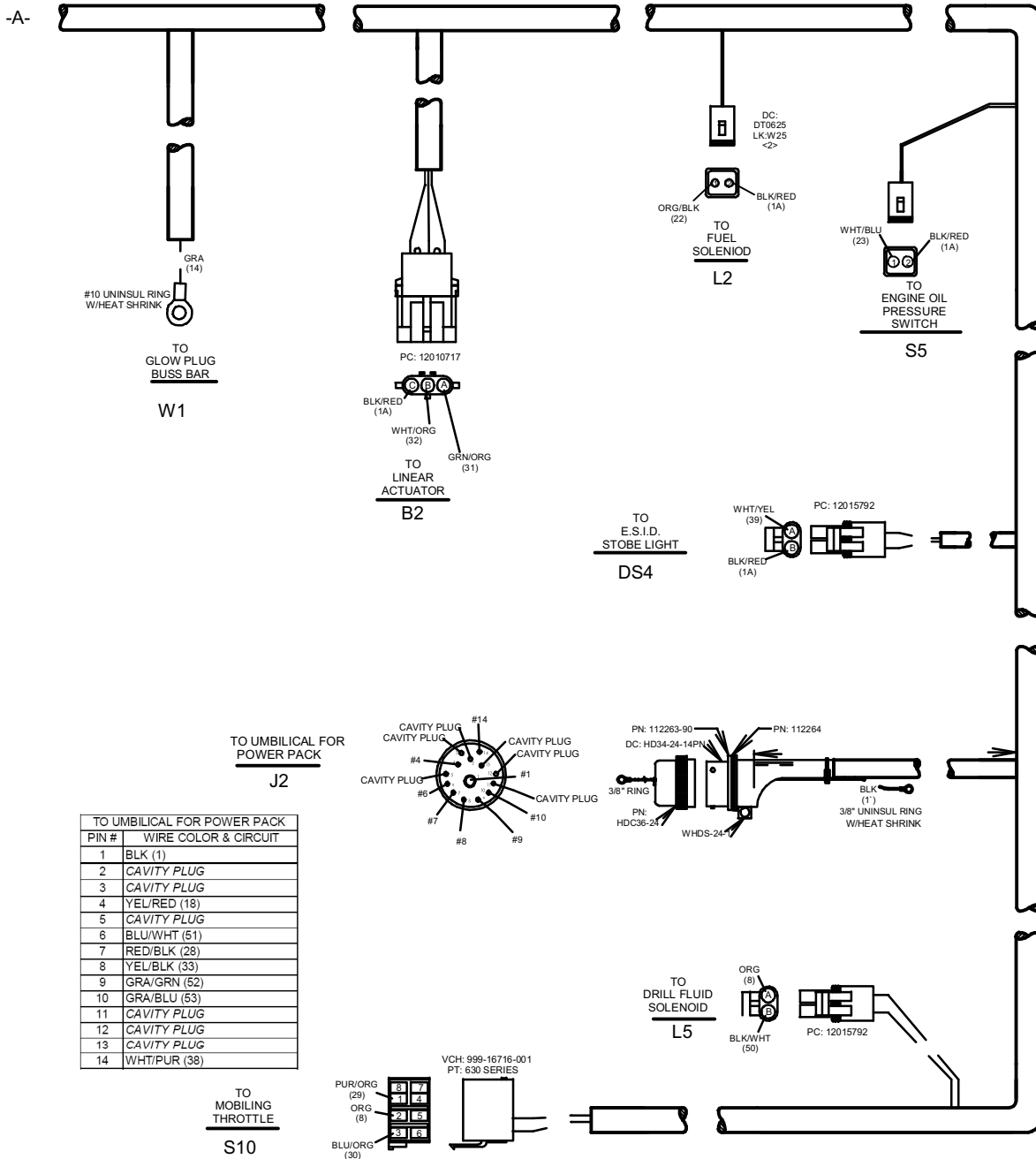

TO UMBILICAL FOR POWER PACK

PIN #	WIRE COLOR & CIRCUIT
1	BLK (1)
2	CAVITY PLUG
3	CAVITY PLUG
4	YEL/RED (18)
5	CAVITY PLUG
6	BLU/WHT (51)
7	RED/BLK (28)
8	YEL/BLK (33)
9	GRA/GRN (52)
10	GRA/BLU (53)
11	CAVITY PLUG
12	CAVITY PLUG
13	CAVITY PLUG
14	WHT/PUR (38)

ENGINE/FRAME HARNESSJT921, JT921S,
JT921P, JT921SP

REF NO.	PART NUMBER	QTY	DESCRIPTION	REMARKS
1.	213-171	1	ENGINE/FRAME HARNESS JT920C	

NOT SHOWN:

FOOTNOTES:

NOTE:

ELECTRICAL STRIKE SYSTEM

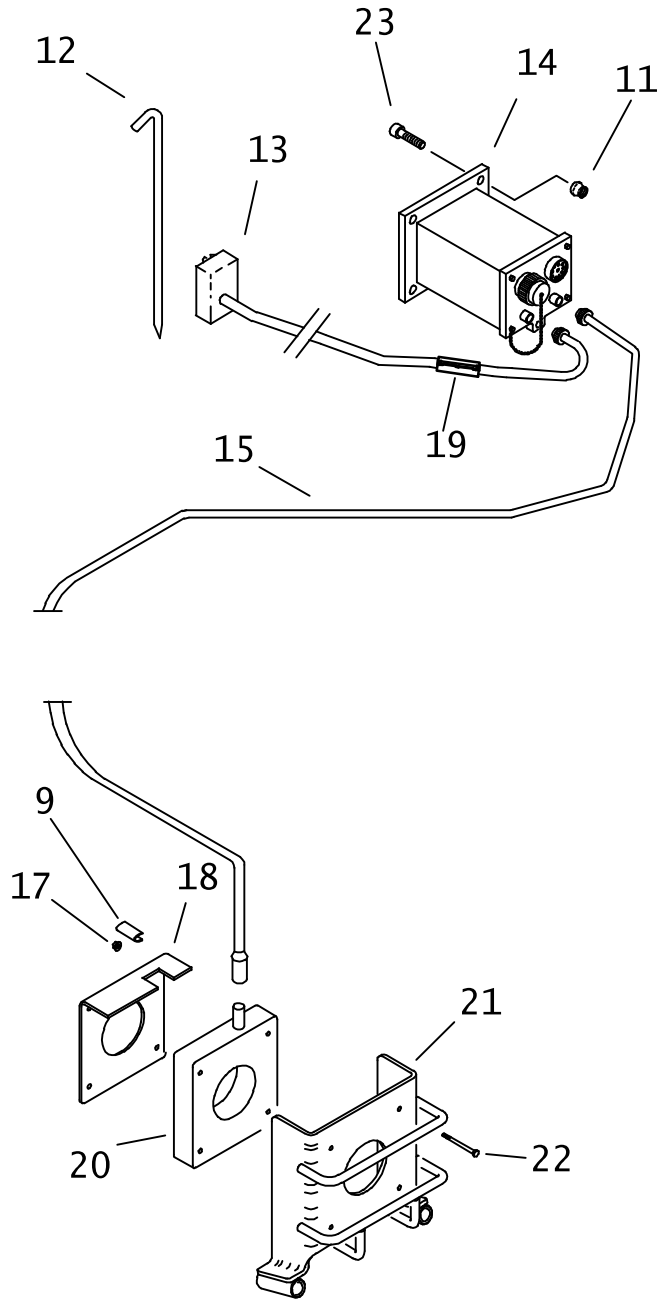
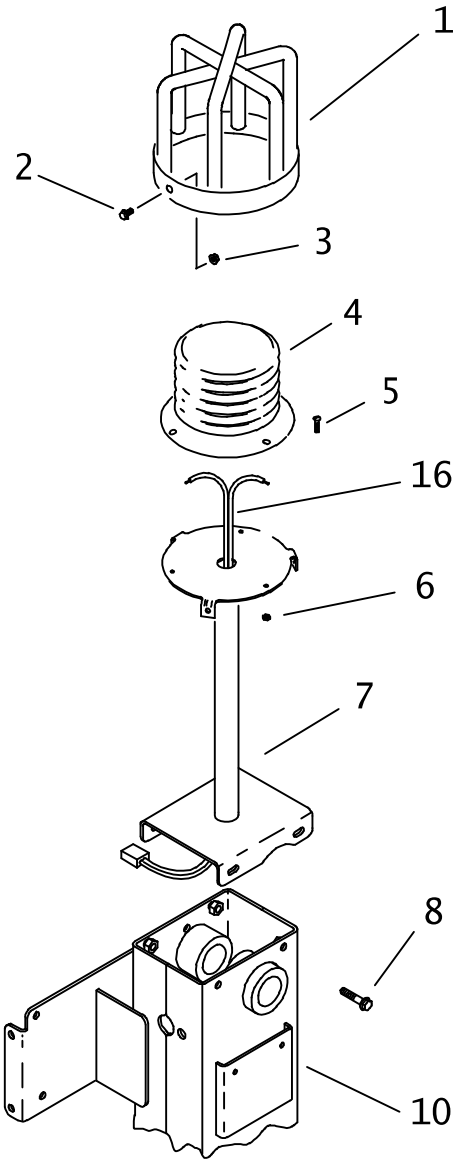

ELECTRICAL STRIKE SYSTEM

REF NO.	PART NUMBER	QTY	DESCRIPTION	REMARKS
1.	362-620	1	LIGHT COVER	
2.	105-836	3	FLG LOCK BOLT (1/4-NC X 1/2")	
3.	105-832	3	FLG LOCKNUT (1/4-NC)	
4.	217-310	1	STROBE LIGHT (12V DC)	
	217-311	1	BULB (12 V DC)	
	121-055	1	LENS (AMBER)	
5.	105-815	3	BOLT (#10-24 X 1", PAN SLT)	
6.	106-048	3	LOCKNUT (#10-24)	
7.	363-507	1	LIGHT POST WELDM'T	
8.	105-825	4	FLG LK BOLT (3/8-NC X 3/4")	
9.	115-671	-	BULK EDGE (1/16" SOLD PER 1")	
10.	353-289	-	UPPER STABILIZER TUBE	W/O WATER TANK
	353-290	-	UPPER STABILIZER TUBE - WET	WITH WATER TANK
11.	106-670	4	NUTSERT (M6-1.00)	
12.	215-799	1	VOLTAGE STAKE	
13.	216-032	-	VOLT LIMITER (EL STR SYSTM)	
	211-042	1	VOLTAGE LIMITER CABLE	
14.	220-027	-	CONTROL MODULE	
	274-483	1	ESID GRAPHIC OVERLAY	
	274-727	1	"Z" FCC LABEL W/ (CE) MARK	
	217-241	1	ESID MODULE	
	197-232	-	ESID MODULE REBUILT	REPLACEMENT FOR 217-232
	197-079	-	ESID MODULE - REBUILT	REBUILT 217-241
15.	214-173	-	ELEC STR SYS CABLE (3.7M)	
	214-554	1	CURRENT COIL CABLE	
16.	214-175	1	STROBE PIGTAIL HARNESS	
17.	106-386	4	FLG LOCKNUT (M8-1.25)	
18.	305-997	1	BACK COIL COVER	
19.	217-331	1	SMALL FERRITE CLAMP-ON	
20.	211-083	1	CURRENT TRANSFORMER	
	101-143	1	CURRENT TRANSFORMER KIT, SM	
21.	318-993	1	COIL COVER	
22.	105-843	4	SCREW (M6-1.00 X 80mm)	
23.	106-640	4	SCREW (M6-1.00 X 20mm, BUT SOC)	

NOT SHOWN:

FOOTNOTES:

NOTE:

CONSOLE HARNESS

JT921, JT921S,
JT921P, JT921SP

R4
MUD POT

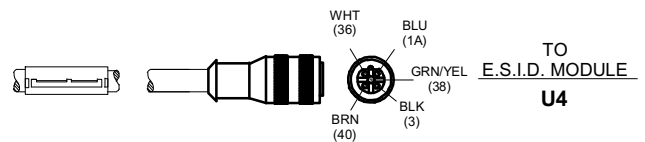
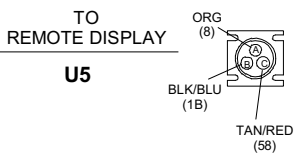
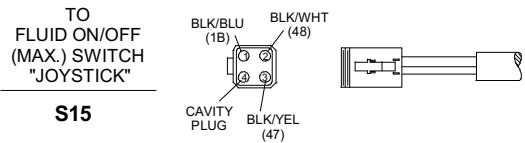
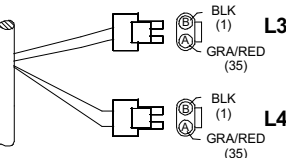
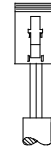
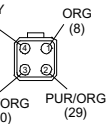
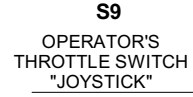
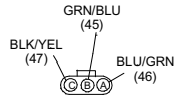
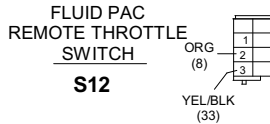
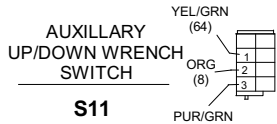

CONSOLE HARNESS

JT921, JT921S,
JT921P, JT921SP

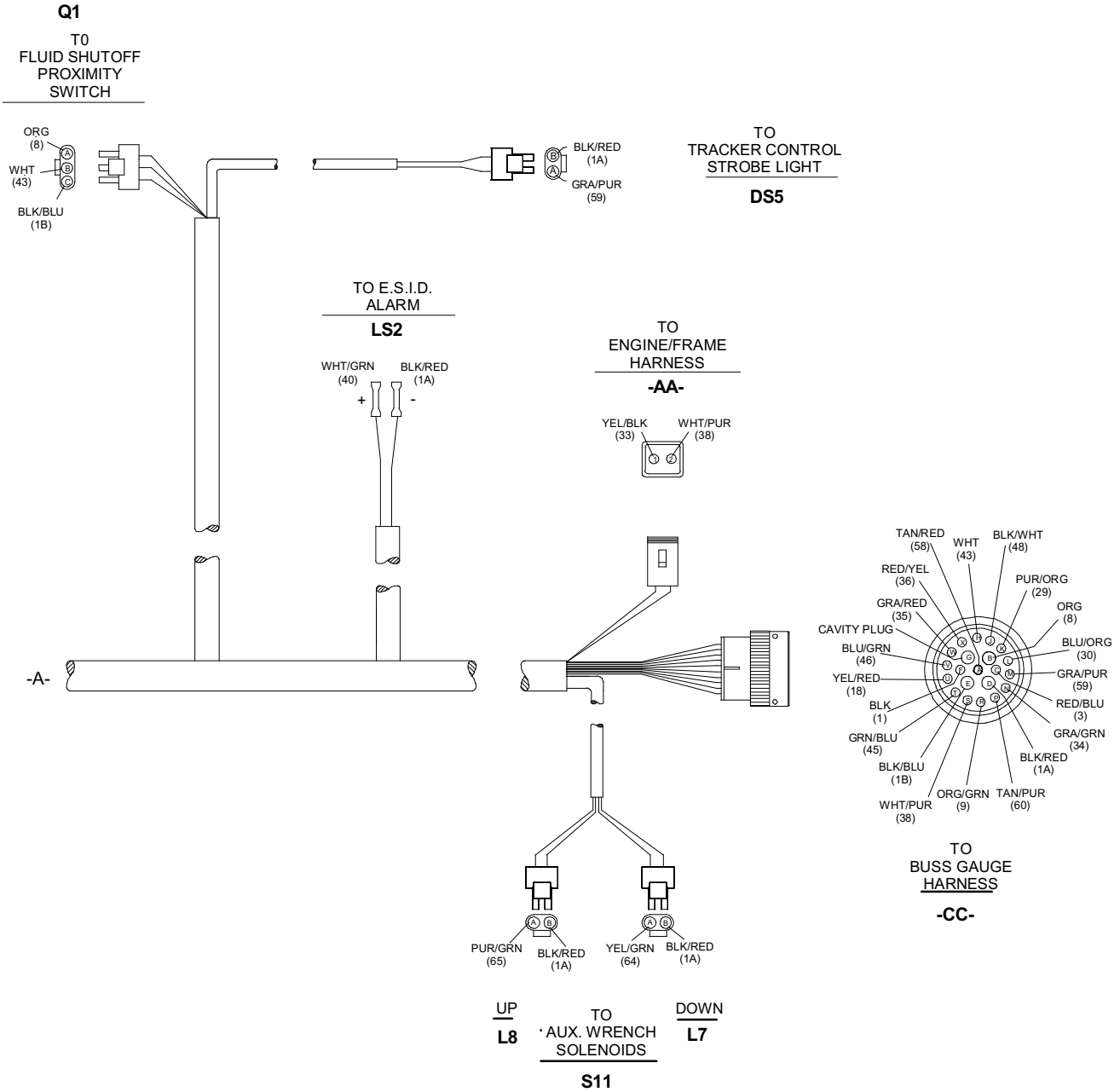

CONSOLE HARNESS

JT921, JT921S,
JT921P, JT921SP

REF NO.	PART NUMBER	QTY	DESCRIPTION	REMARKS
1.	213-170	1	CONSOLE HARNESS JT920C	

NOT SHOWN:

FOOTNOTES:

NOTE:

GAUGE BUSS HARNESS

JT921, JT921S,
JT921P, JT921SP

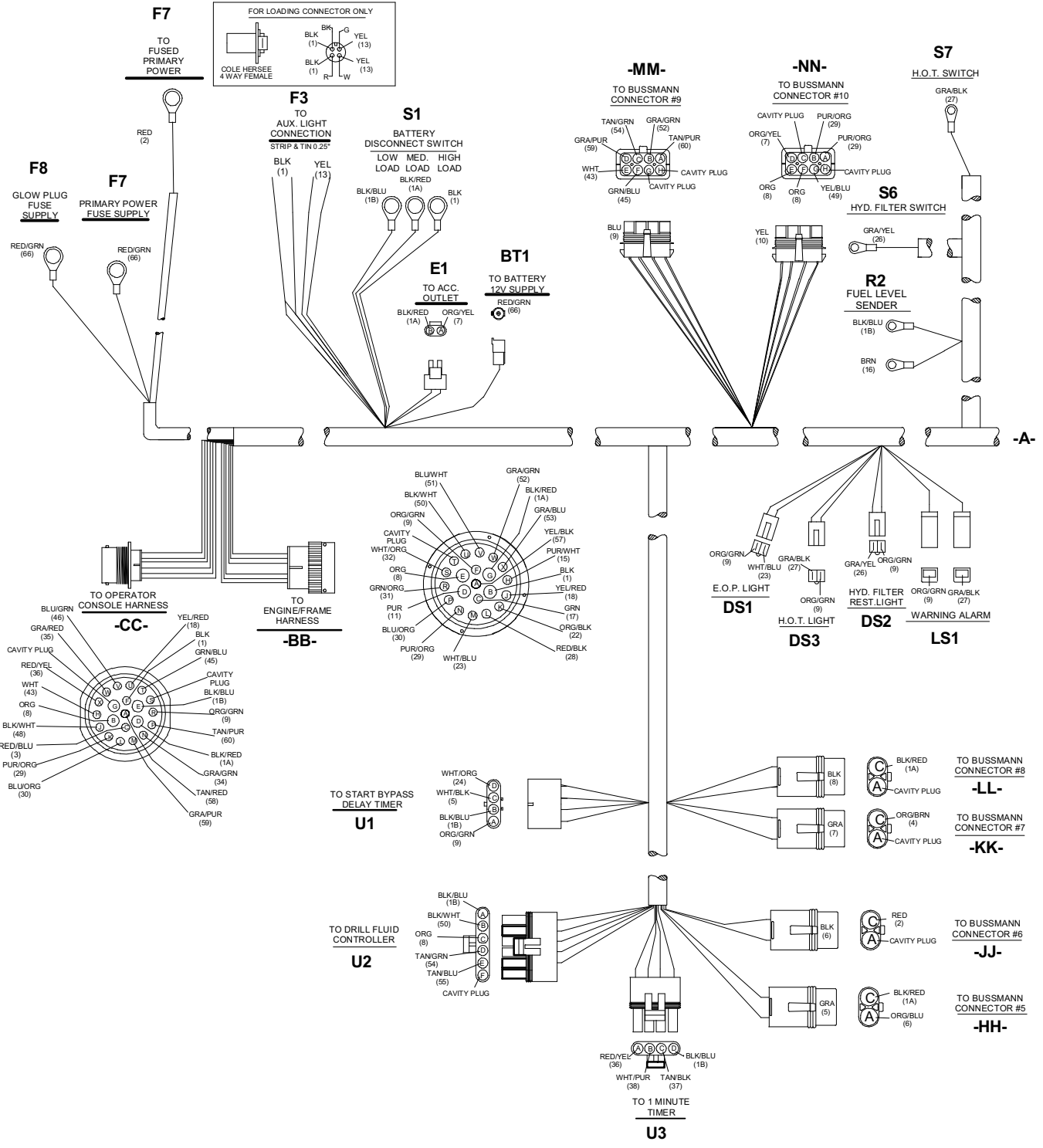

GAUGE BUSS HARNESS

JT921, JT921S,
JT921P, JT921SP

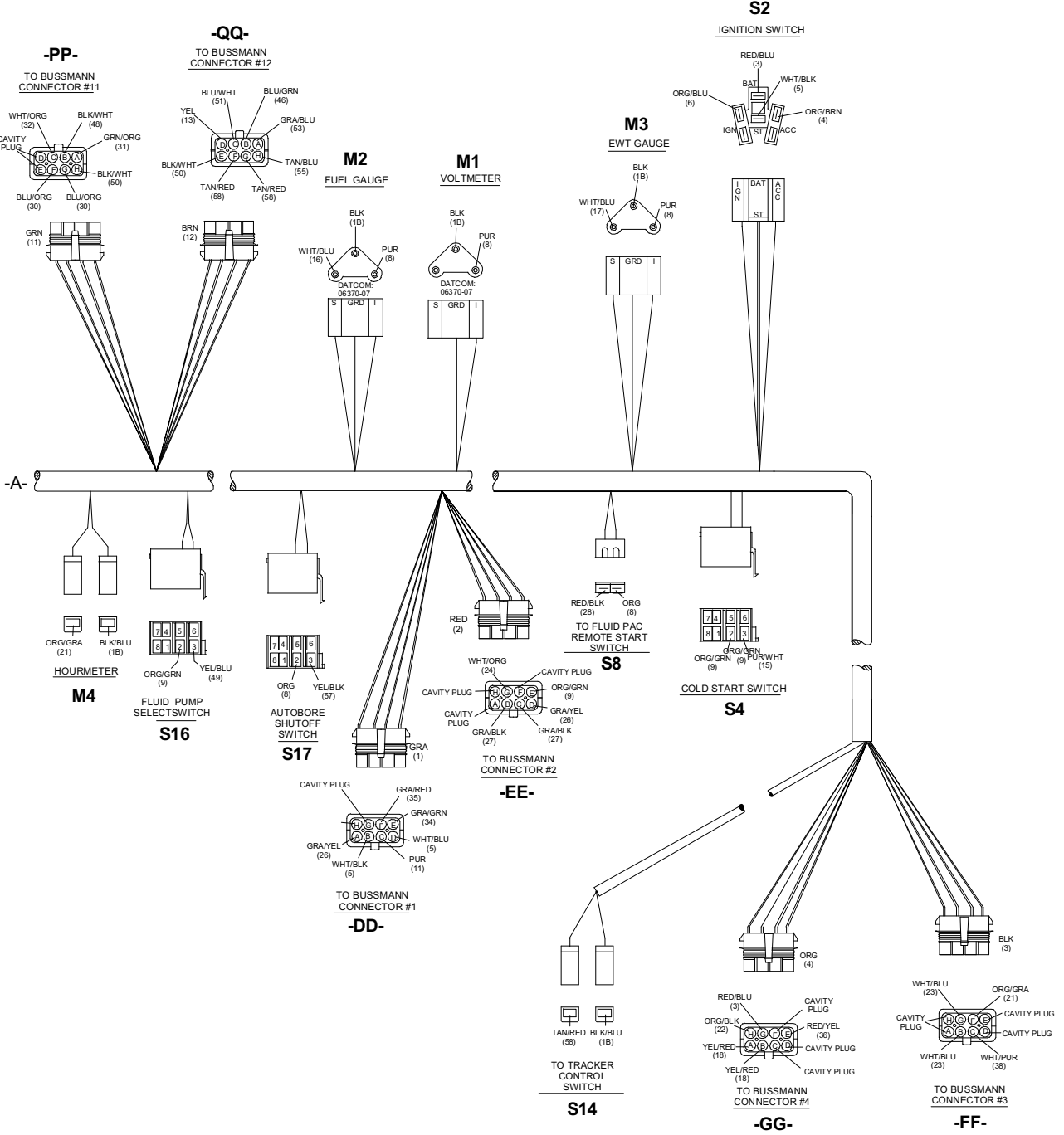

GAUGE BUSS HARNESS

JT921, JT921S,
JT921P, JT921SP

REF NO.	PART NUMBER	QTY	DESCRIPTION	REMARKS
1.	213-169	1	GAUGE BUSS HARNESS JT920C	

NOT SHOWN:

FOOTNOTES:

NOTE:

LUBRICATOR SYSTEMS

THREAD LUBRICATOR

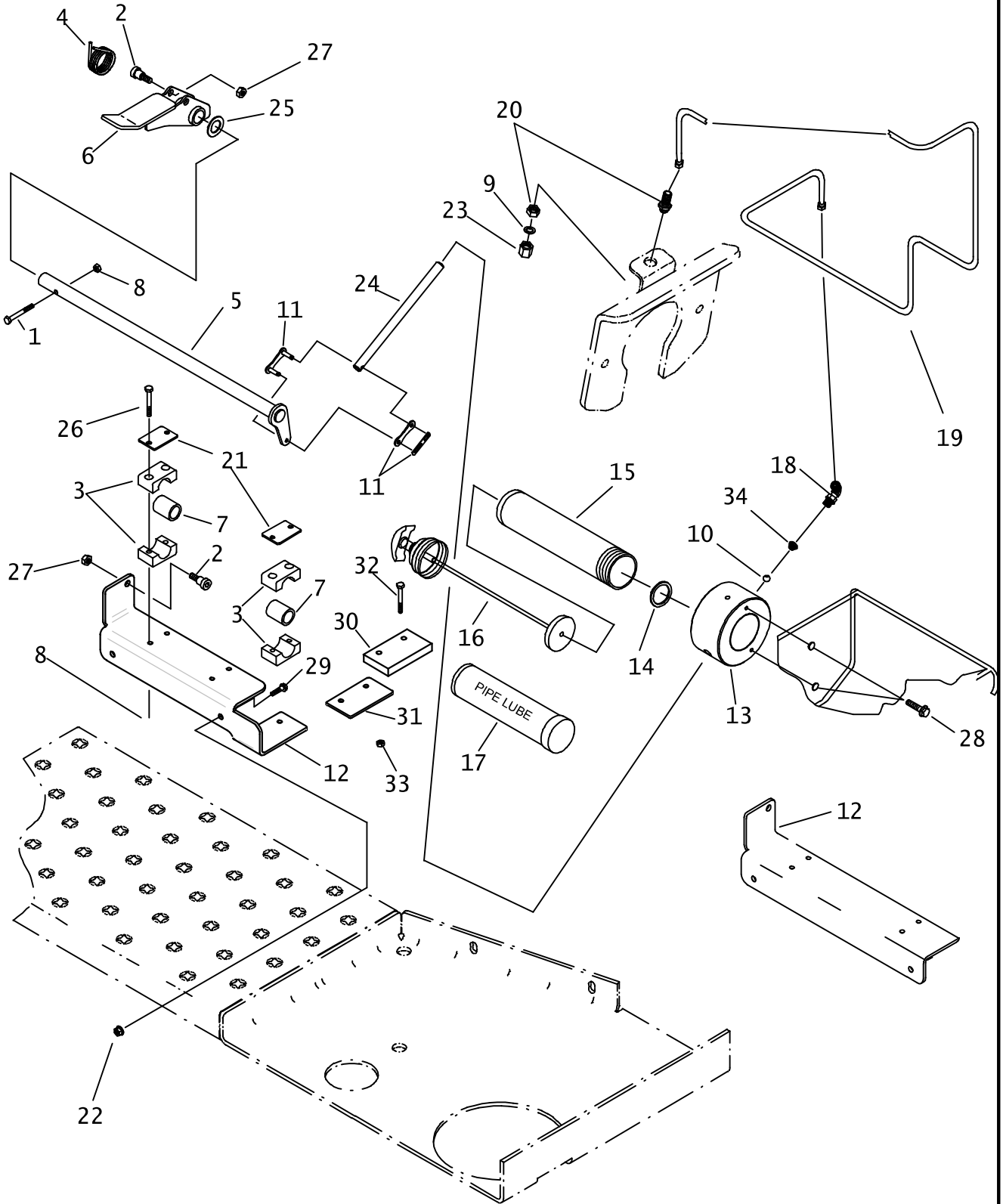

THREAD LUBRICATOR

REF NO.	PART NUMBER	QTY	DESCRIPTION	REMARKS
1.	105-818	1	BOLT (1/4-NC X 1-1/2")	
2.	106-070	2	SHLD BLT (1/2" X 3/8", 3/8-NC)	
3.	110-573	2	BOLT-ON CLAMP (1",SOLD PER SET)	
4.	117-257	1	TORSION SPRING	
5.	307-879	1	SHAFT	
6.	303-371	1	PEDAL	
7.	125-301	2	COMPOSITION BUSHING (.750")	
8.	105-085	5	LOCKNUT (1/4-NC)	
9.	105-890	1	SEAL WASHER (7/16")	
10.	125-136	1	DETENT BALL (.187", CHROME)	
11.	130-331	1	CONNECTOR LINK (1-1/4")	
12.	307-873	1	PIVOT BRACKET	BEFORE S/N
	329-298	1	PIVOT BRACKET	AFTER S/N
13.	359-925	1	LUBER BASE	
14.	157-716	1	GREASE SEAL	
15.	359-869	1	GREASE BARREL	
16.	359-871	1	PLUNGER	
17.	256-663	1	GREASE (14 OZ CARTRIDGE)	
	256-026	1	GREASE (14 OZ CART, ARTIC GD)	
18.	154-342	1	CONNECTOR (06S-06090)	
19.	149-879	1	HYD LINE (-06)	
20.	514-163	1	BK CONNECTOR (060-060BK)	
21.	322-289	2	BACKUP (BOLT-ON)	
22.	106-386	2	LOCKNUT (M8-1.25,PRV TRQ,10.9)	
23.	149-221	1	NOZZLE	
24.	307-874	1	PLUNGER	
25.	110-095	1	MACHINERY BUSHING (3/4", 18GA)	
26.	105-106	4	BOLT (1/4-NC X 2")	
27.	105-047	2	LOCKNUT (3/8-NC)	
28.	106-382	2	FLG LK SCREW (M10-1.5 X 20mm)	
29.	106-162	2	FLG SCREW (M8-1.25 X 20mm)	
30.	307-414	1	POLY GUIDE BLOCK	
31.	118-461	1	SHIM (.135)	
32.	106-327	2	SCREW (M8-1.25 X 30mm)	
33.	106-386	2	FLG LOCKNUT (M8-1.25)	
34.	117-162	1	COMPRESSION SPRING (.438")	

NOT SHOWN:

FOOTNOTES:

NOTE:

NOTES:

ANCHOR SYSTEMS

ANCHOR SYSTEM

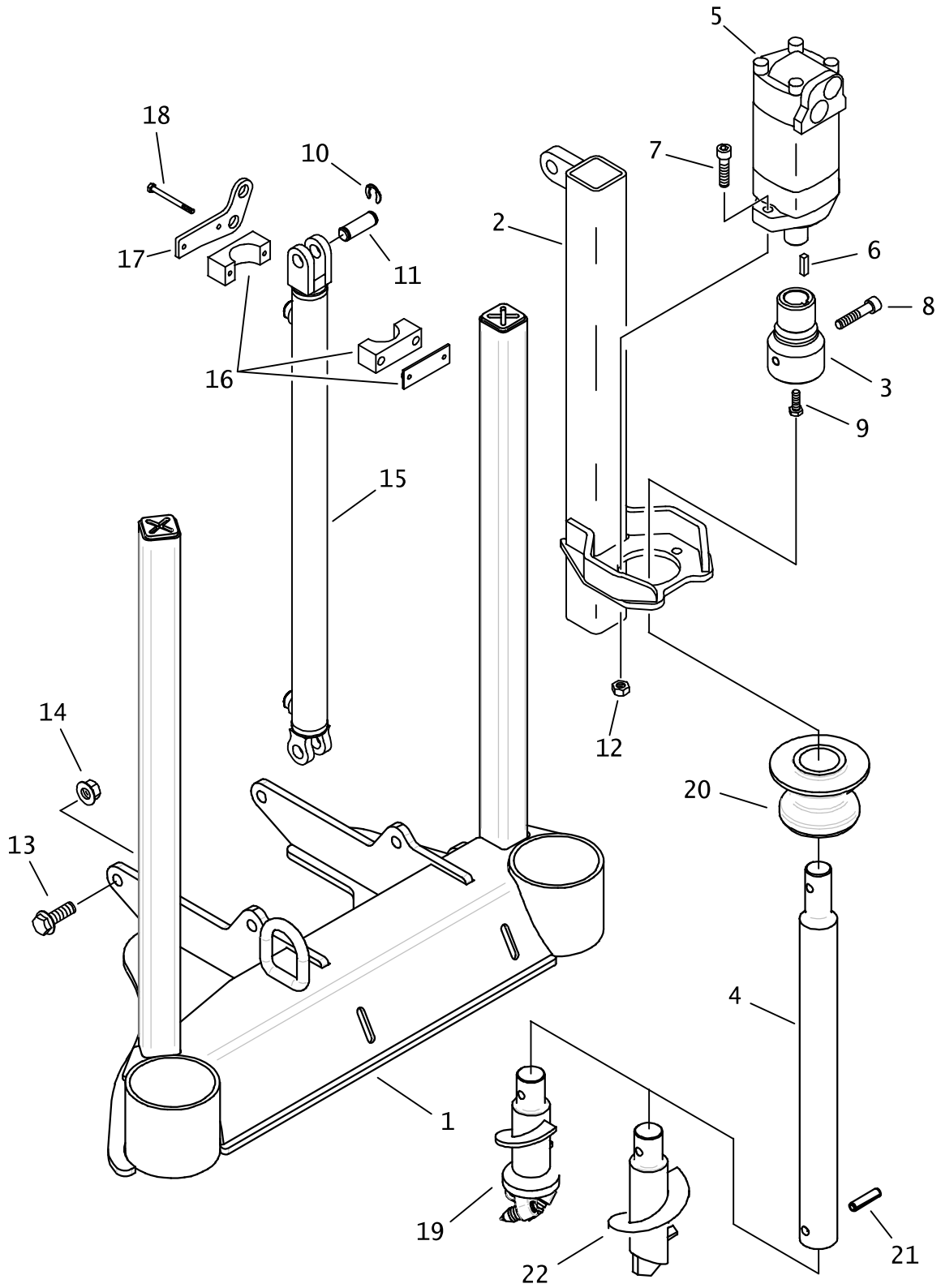

ANCHOR SYSTEM

REF NO.	PART NUMBER	QTY	DESCRIPTION	REMARKS
1.	329-299	1	ANCHOR FRAME	
2.	316-767	2	UPPER TUBE	
3.	316-801	2	ANCHOR DRIVER	
4.	166-605	2	SHAFT	
5.	158-700	2	HYD MOTOR	INCL. REF #6
	500-658	-	SEAL REPAIR KIT	
	166-278	-	SHAFT ASSEMBLY	
6.	165-909	-	KEY (5/16" X 1-1/8")	
7.	106-707	4	SCREW (M12-1.75 X 45MM, SOC)	
8.	106-771	2	SCREW (M12-1.75 X 60MM, SOC)	
9.	105-052	2	BOLT (3/8-NC X 1-1/4")	
10.	115-503	8	KLIP RING (.750")	
11.	179-736	4	PIN	
12.	106-685	4	LOCKNUT(M12-1.75,PRV TRQ,10.9)	
13.	107-336	4	FLG SCREW (M16-2.00X45MM,10.9)	
14.	106-355	4	FLG NUT (M16-2.00, 10.9)	
15.	151-214	2	HYD CYL	
	500-1542	-	SEAL KIT	
16.	318-631	2	BOLT-ON CLAMP (1.88")	
17.	318-658	2	BULKHEAD BRACKET	
18.	107-196	4	BOLT (1/4-NC X 3")	
19.	327-457	-	ROCK ANCHOR	
	131-259	-	INSERT BIT - CARBIDE TIPPED	
20.	158-238	2	CENTERING CAP	
21.	107-331	2	ROLL PIN (M12 X 50MM)	
22.	327-460	-	AUGER (4")	

NOT SHOWN:

FOOTNOTES:

NOTE:

ANCHOR COUNTERBALANCE WEIGHT

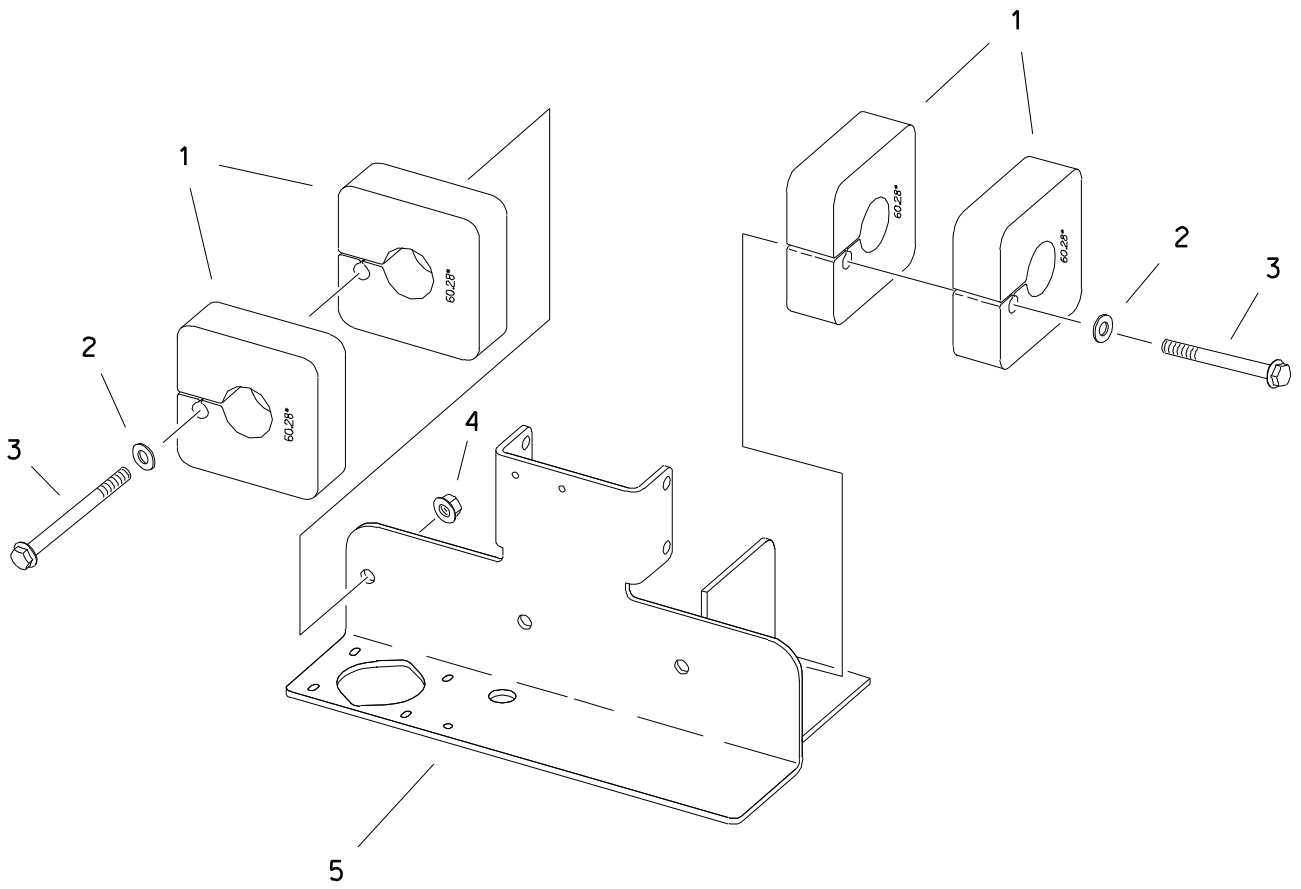

ANCHOR COUNTERBALANCE WEIGHT

REF NO.	PART NUMBER	QTY	DESCRIPTION	REMARKS
	190-779	-	CNTRBL W/FLUID, NO TANK	SEE FOOTNOTE 1
	190-780	-	CNTRBL W/ANCHOR SYS W/O FLUID	SEE FOOTNOTE 1
1.	317-605	6	FRONT WEIGHT	(WITHOUT FLUID)
		4	FRONT WEIGHT	(WITH FLUID, NO TANK)
2.	105-384	6	WASHER (3/4")	(WITHOUT FLUID)
		4	WASHER (3/4")	(WITH FLUID, NO TANK)
3.	105-480	3	BOLT (3/4-NC X 8")	(WITHOUT FLUID)
		2	BOLT (3/4-NC X 8")	(WITH FLUID, NO TANK)
4.	105-953	3	LOCKNUT (3/4-NC)	(WITHOUT FLUID)
		2	LOCKNUT (3/4-NC)	(WITH FLUID, NO TANK)
5.	350-622	1	MUD PUMP/WEIGHT SUPPORT	

FOOTNOTES

1. 190-779 AND 190-780 ARE KITS FOR AFTERMARKET USE.

ANCHORING PARTS

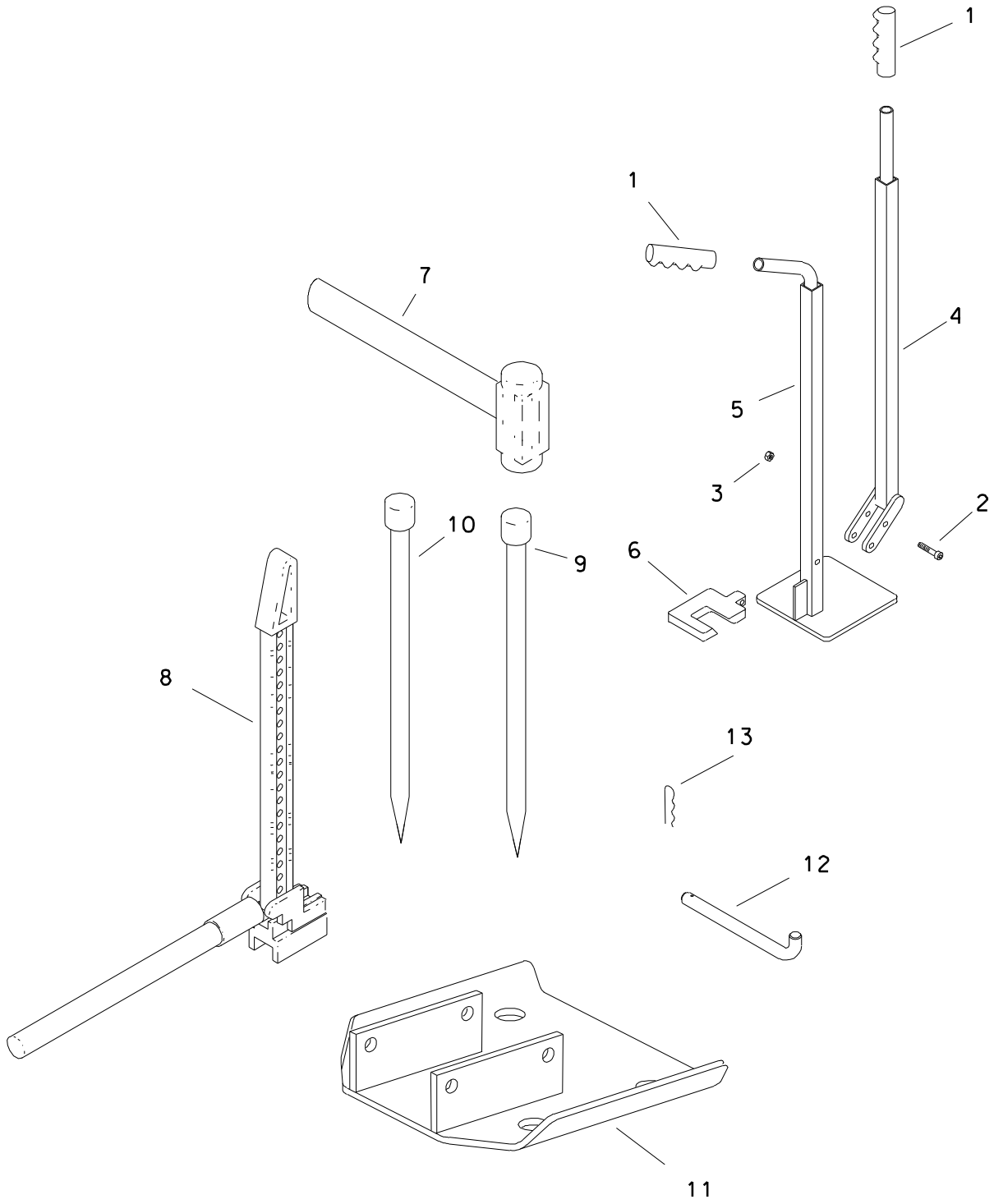

ANCHORING PARTS

REF NO.	PART NUMBER	QTY	DESCRIPTION	REMARKS
	355-654		STAKE JACK	INCL REF NO'S 1-6
1.	110-013	2	HAND GRIP (1", BLK)	
2.	105-880	2	SHOULDER BOLT (3/8" X 2", 5/16-NC)	
3.	105-089	2	LOCK NUT (5/16-NC)	
4.	355-656	1	LEVER	
5.	355-655	1	BASE	
6.	355-657	1	GRIP PLATE	
7.	259-084	1	SLEDGE HAMMER (12LBS)	
8.	355-145	1	HILO JACK PULLER-STAKE	STAKE
9.	355-367	6	STAKE	SEE FOOTNOTE 1
	355-188	6	STAKE (HYD DRIVER)	SEE FOOTNOTE 1
	355-189	1	STAKE	
	355-199	1	STAKE CAP	
	105-555	1	ROLL PIN (.375" X 2-1/2")	
	105-556	1	ROLL PIN (.219" X 2-1/2")	
10.	355-367	6	STAKE	SEE FOOTNOTE 2
	355-258	6	FRAME STAKE (1-1/2")	SEE FOOTNOTE 2
	355-189	1	STAKE	
	355-259	1	STAKE CAP	
	105-555	1	ROLL PIN (.375" X 2-1/2")	
	105-556	1	ROLL PIN (.219" X 2-1/2")	
11.	355-685	4	ANCHOR BRACKET	
12.	183-899	8	PIN	
13.	110-128	8	SPRING CLIP PIN (5/32" X 1")	

FOOTNOTES

1. USED WITH HYDRAULIC DRIVER
2. USED WHEN NOT USING HYDRAULIC DRIVER

HYDRAULIC STAKE DRIVER

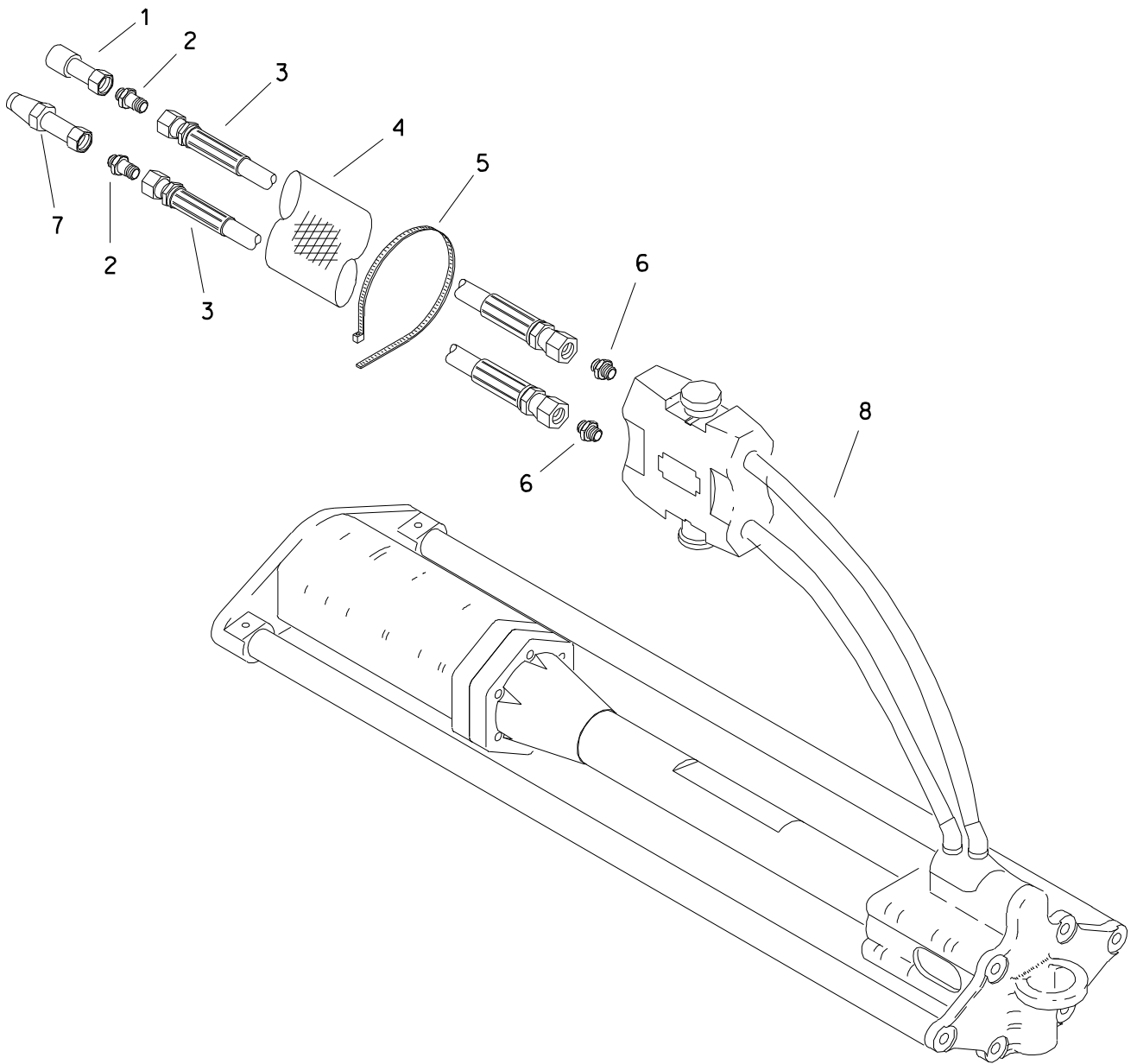

HYDRAULIC STAKE DRIVER

REF NO.	PART NUMBER	QTY	DESCRIPTION	REMARKS
	<u>100-965</u>		HYD STAKE DRIVER ASS'Y	SEE FOOTNOTE 1
1.	159-029	1	QDC BODY (08-08SF)	
2.	154-222	2	CONNECTOR (06D-08S)	
3.	155-481	2	HOSE (06DFX-185"-3000PSI)	
4.	115-900	1	ABRASION SLEEVE (2.54' X 190")	
5.	110-030	AR	CABLE TIE (1/16" TO 4")	
6.	514-077	2	CONNECTOR (06N-06D)	
7.	159-030	1	QDC ADAPTER (08-08SF)	
8.	355-268	1	HYDRAULIC STAKE DRIVER	
	500-716	-	SEAL REPAIR	

FOOTNOTES

NOT RECOMMENDED FOR USE WITH THE HOSE REEL.

NOTE

REFER TO O-RING CHART (800-301) IN BACK OF BOOK FOR REPLACEMENT OF SAE AND ORS O-RINGS.

FLUID SYSTEMS

TANK SUPPORT

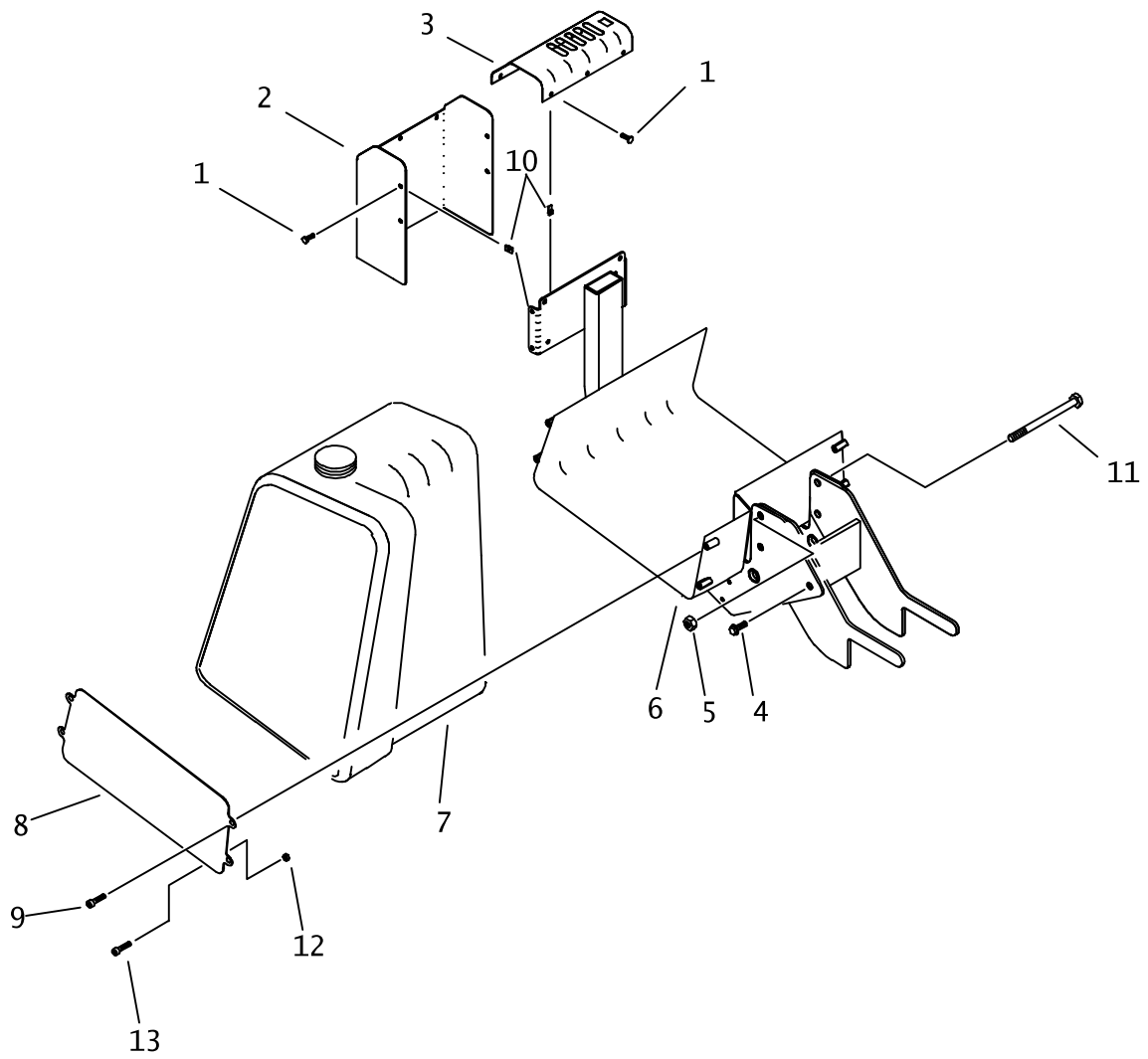

TANK SUPPORT

REF NO.	PART NUMBER	QTY	DESCRIPTION	REMARKS
1.	106-992	12	FLG LK SCREW (M8-1.25 X 25mm)	
2.	353-864	1	VALVE COVER	
3.	344-760	1	VALVE COVER	BEGINS WITH S/N 2N2402
4.	106-098	2	FLG BOLT (3/4-NC X 2", GD8)	
5.	105-340	4	FLG LOCKNUT (3/4-NC)	
6.	353-822	1	WATER TANK SUPPORT	
7.	364-276	1	WATER TANK (63.0 GAL)	
	157-488		CAP/LID (WATER TANK)	BEGINS WITH S/N 2W0228
	157-490		BK CONNECTOR (16NF, POLY)	SEE FOOTNOTE 2
	157-189		O-RING (325 D70)	
	190-053		POLY PATCH TANK REPAIR KIT	
8.	353-168	1	SIDE PLATE	
9.	105-248	4	SCREW (M12-1.75 X 25mm, SOC)	
10.	106-551	12	CLIP NUT (M8-1.25)	SEE FOOTNOTE 1
11.	106-188	2	BOLT (3/4-NC X 10")	
12.	105-834	3	FLG LOCKNUT (3/8-NC)	
13.	105-825	3	FLG LK BOLT (3/8-NC X 3/4")	

FOOTNOTES

1. TORQUE BOLT TO 271 N-M (200FT-LBS)
2. HOLES MAY REQUIRE MODIFICATION FOR NEW FITTINGS.

NOTE:

REFER TO O-RING CHART (800-301) IN BACK OF THE BOOK FOR REPLACEMENT OF O-RINGS.

MUD PUMP

SEE FOOTNOTE 1

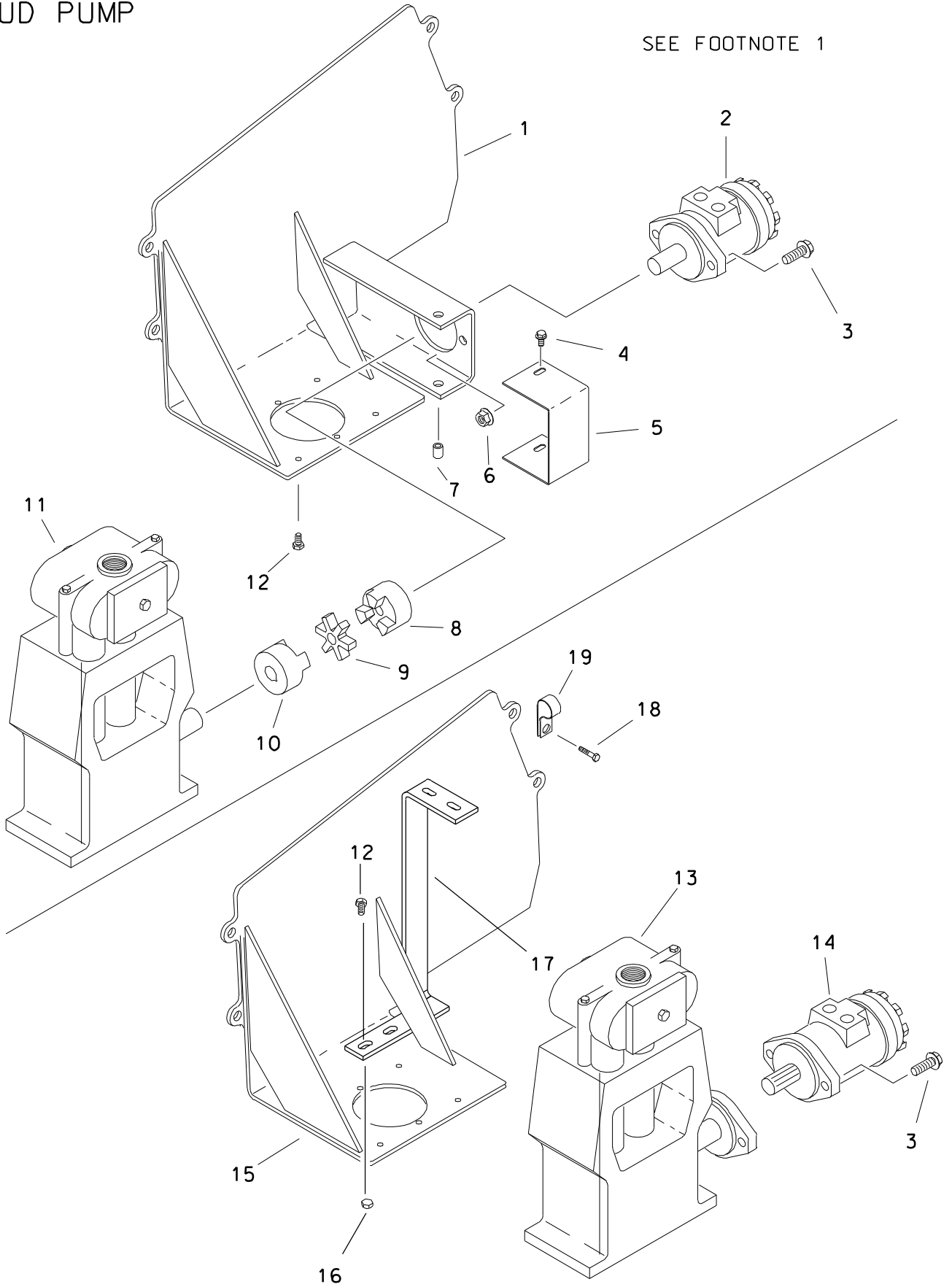

MUD PUMP

REF NO.	PART NUMBER	QTY	DESCRIPTION	REMARKS
1.	344-566	1	SIDE	SEE FOOTNOTE 1 FOR REF #'S 1 - 12
2.	158-403	1	GEAR MOTOR (3.0 CUI/REV)	
	190-725	1	SEAL REPAIR KIT	
	165-931	1	WOODRUFF KEY (1/4" X 1")	
3.	106-204	4	BOLT (1/2-NC X 1-1/2", SOC)	USE LOCTITE 242, TORQUE 100 FT LBS
4.	106-380	3	FLG LK SCREW (M8-1.25 X 16MM)	
5.	353-253	1	COVER	
6.	106-709	2	FLG LOCKNUT (M12-1.75)	
7.	106-565	3	NUTSERT (M8-1.25)	
8.	355-971	1	FLANGE COUPLER (1")	
9.	353-245	1	SPIDER CENTER (1.070")	
10.	353-246	1	FLANGE COUPLER (7/8")	
11.	158-411	1	MUD PUMP	
	190-933	1	PACKING REPAIR KIT (MUD PUMP)	
	190-815	2	VALVE REPAIR KIT	
	499-014	1	PUMP CASE	
	499-015	2	VALVE CHAMBER / FLUID CYLINDER	
	500-903	2	CERAMIC CYLINDER	
12.	105-826	6	FLG LK BOLT (3/8-NC X 1")	
13.	158-465	1	MUD PUMP	SEE FOOTNOTE 2 FOR REF #'S 13-15
	190-933	1	PACKING REPAIR KIT (MUD PUMP)	
	190-815	2	VALVE REPAIR KIT	
14.	158-469	1	GEAR MOTOR (3.0 CUI/REV)	
	190-725	1	SEAL REPAIR KIT	
15.	315-886	1	MUD PUMP SUPPORT w/ FILTER	
SUPPORT				
16.	105-834	2	NUT (3/8-NC)	
17.	318-394	1	FILTER SUPPORT	
18.	105-248	1	SCREW (M12-1.75 X 25MM, SOC)	
19.	110-332	1	BOLT-ON CLAMP (1-5/8")	

FOOTNOTES

- 1. REF #'S 1-12 ENDS WITH S/N2N2089
- 2. REF #'S 13-15 BEGINS WITH S/N2N2090

MUD PUMP
9 GPM

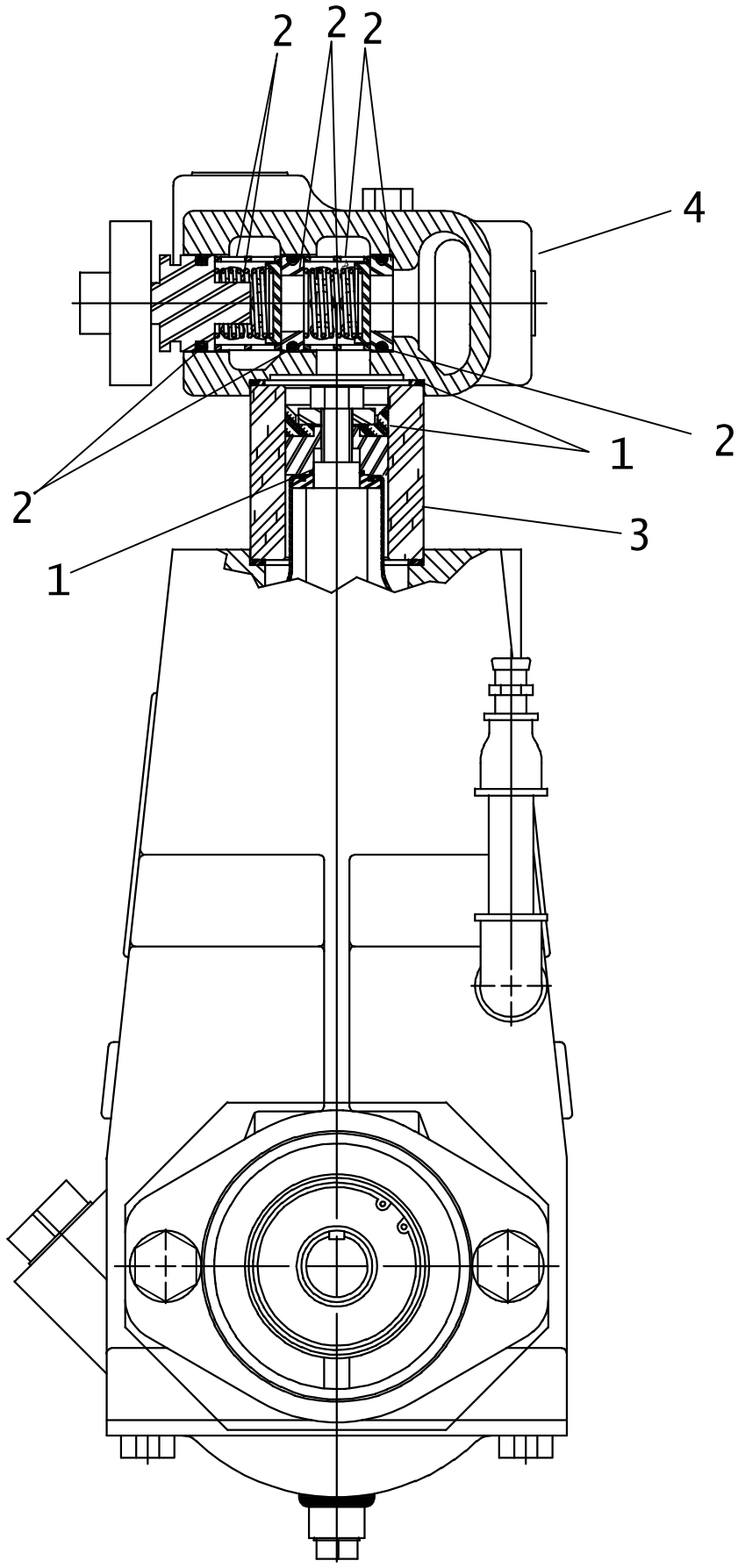

MUD PUMP

9 GPM

REF NO.	PART NUMBER	QTY	DESCRIPTION	REMARKS
	158-465	-	MUD PUMP	BEGINS WITH S/N 2N2090
1.	190-933	1	PACKING REPAIR KIT (MUD PUMP)	
2.	190-815	2	VALVE REPAIR KIT	
3.	500-903	2	CERAMIC CYLINDER	
4.	499-015	1	FLUID CYLINDER (HEAD)	

NOT SHOWN:

499-086 2 VALVE COVER

FOOTNOTES:

NOTE:

MUD PUMP PLUMBING

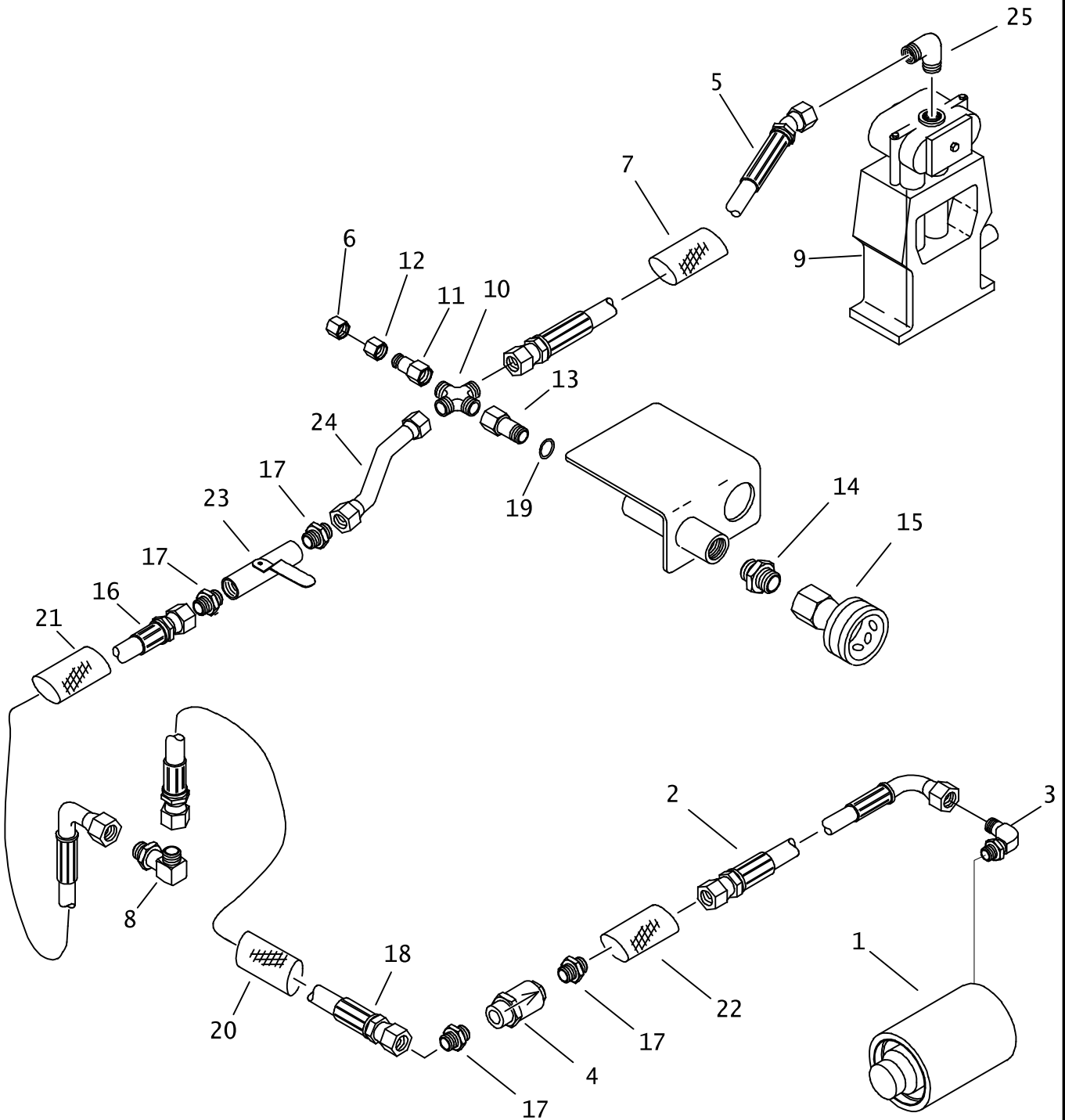

MUD PUMP PLUMBING

REF NO.	PART NUMBER	QTY	DESCRIPTION	REMARKS
1.	159-240	-	WATER SWIVEL	OBSOLITE
	153-242	-	WATER SWIVEL	
2.	515-003	1	HOSE (080FX90-31"-3000)	
3.	154-490	AR	CONNECTOR (12N-08090)	
4.	149-324	1	FLOW CHECK (08NF-08NF/64PSI)	
	190-963	-	REPAIR KIT (CHECK VALVE)	
5.	154-747	1	HOSE (080FX45-21"-3000)	USE WITH JT921S
	154-829	1	HOSE (080FX45-19"-3000)	
6.	154-296	1	CAP (040F)	
7.	117-672	1	ABRASION SLEEVE (1.00" X 20")	
8.	154-396	1	BK CONNECTOR (080-08090BK)	
9.	158-465	.1	MUD PUMP	
10.	514-145	1	CROSS (080)	
11.	154-248	2	REDUCER STEM (040)	
12.	154-272	2	REDUCER NUT (080F)	
13.	156-732	1	CONNECTOR (08J-080)	
14.	154-466	1	CONNECTOR (08S-08S)	
15.	159-088	1	QDC BODY (08-08SF)	
	190-186	-	SEAL REPAIR KIT	
	155-936	1	DUST PLUG (1/2"-3/4")	
16.	154-971	1	HOSE (080FX90-78"-3000)	
17.	154-349	4	CONNECTOR (08N-080)	
18.	515-073	1	HOSE (080FX-127"-3000)	
19.	155-706	1	O-RING (908 D90)	
20.	116-632	1	ABRASION SLEEVE (1.59" X 130")	
21.	117-713	1	ABRASION SLEEVE (1.00" X 76")	
22.	115-754	1	ABRASION SLEEVE (1.59" X 30")	
23.	158-579	1	SHUTOFF (08NF-08NF)	
	110-538	-	VALVE LEVER	
24.	156-590	1	HYD LINE (-08)	
25.	154-352	1	CONNECTOR (08N-08090)	

FOOTNOTES

NOTE:

REFER TO O-RING CHART (800-301) IN BACK OF THE BOOK FOR REPLACEMENT OF O-RINGS.

MUD PUMP PLUMBING W/OUT TANK

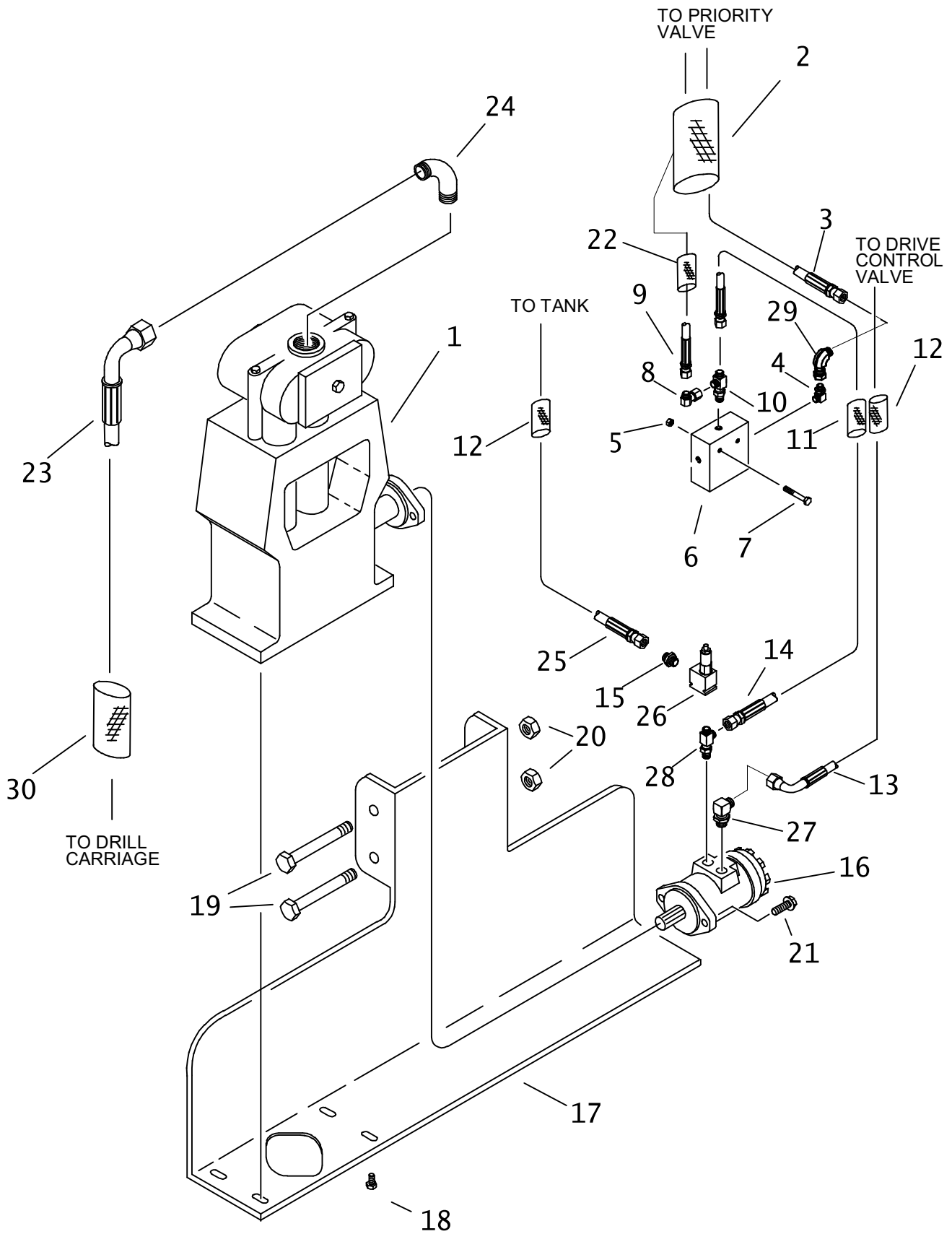

MUD PUMP PLUMBING W/OUT TANK

REF NO.	PART NUMBER	QTY	DESCRIPTION	REMARKS
1.	158-465	1	MUD PUMP	
2.	115-924	1	ABRASION SLEEVE (1.59" X 88")	
3.	154-972	1	HOSE (080FX-94"-3000)	
4.	154-322	1	CONNECTOR (080-10S90)	
5.	106-386	2	FLG LOCKNUT (M8-1.25)	
6.	157-784	1	HYD FLOW VALVE	
7.	106-602	2	SCREW (M8-1.25 X 80mm)	
8.	154-255	1	UNION (040-040FX90)	
9.	154-694	1	HOSE (040FX-98"-3000)	
10.	154-473	1	RUN TEE (10S-080-040)	
11.	117-679	1	ABRASION SLEEVE (1.59" X 32")	
12.	115-811	2	ABRASION SLEEVE (1.59 X 20")	
13.	515-197	1	HOSE (080FX90-23"-3000)	
14.	154-711	1	HOSE (080FX-30"-3000)	
15.	154-233	2	CONNECTOR (08S-080)	
16.	158-469	1	GEAR MOTOR (3.0 CUI/REV)	BEGINS WITH S/N 2N2090
	190-725	1	SEAL REPAIR KIT	
17.	350-622	1	MUD PUMP / WEIGHT SUPPORT	BEGINS WITH S/N 2N2090
18.	105-826	4	FLG LK BOLT (3/8-NC X 1")	
19.	105-971	2	BOLT (3/4-NC X 10-1/2")	
20.	105-340	2	FLG LOCKNUT (3/4-NC)	
21.	105-265	2	FLG BOLT(1/2-NC X 2")	
22.	117-189	1	ABRASION SLEEVE (1.25" X 44")	
23.	154-747	1	HOSE (080FX45-21"-3000)	
24.	154-352	1	CONNECTOR (08N-08090)	
25.	154-674	1	HOSE (080FX-24"-3000)	
26.	158-842	1	RELIEF VALVE (2000PSI)	
27.	154-322	1	CONNECTOR (080-10S90)	
28.	514-378	1	BRANCH TEE (080-10S-08S)	
29.	154-256	1	UNION (080-080FX90)	
30.	117-672	1	ABRASION SLEEVE (1.00" X 20")	

NOT SHOWN:

FOOTNOTES:

NOTE:

MUD TANK PLUMBING

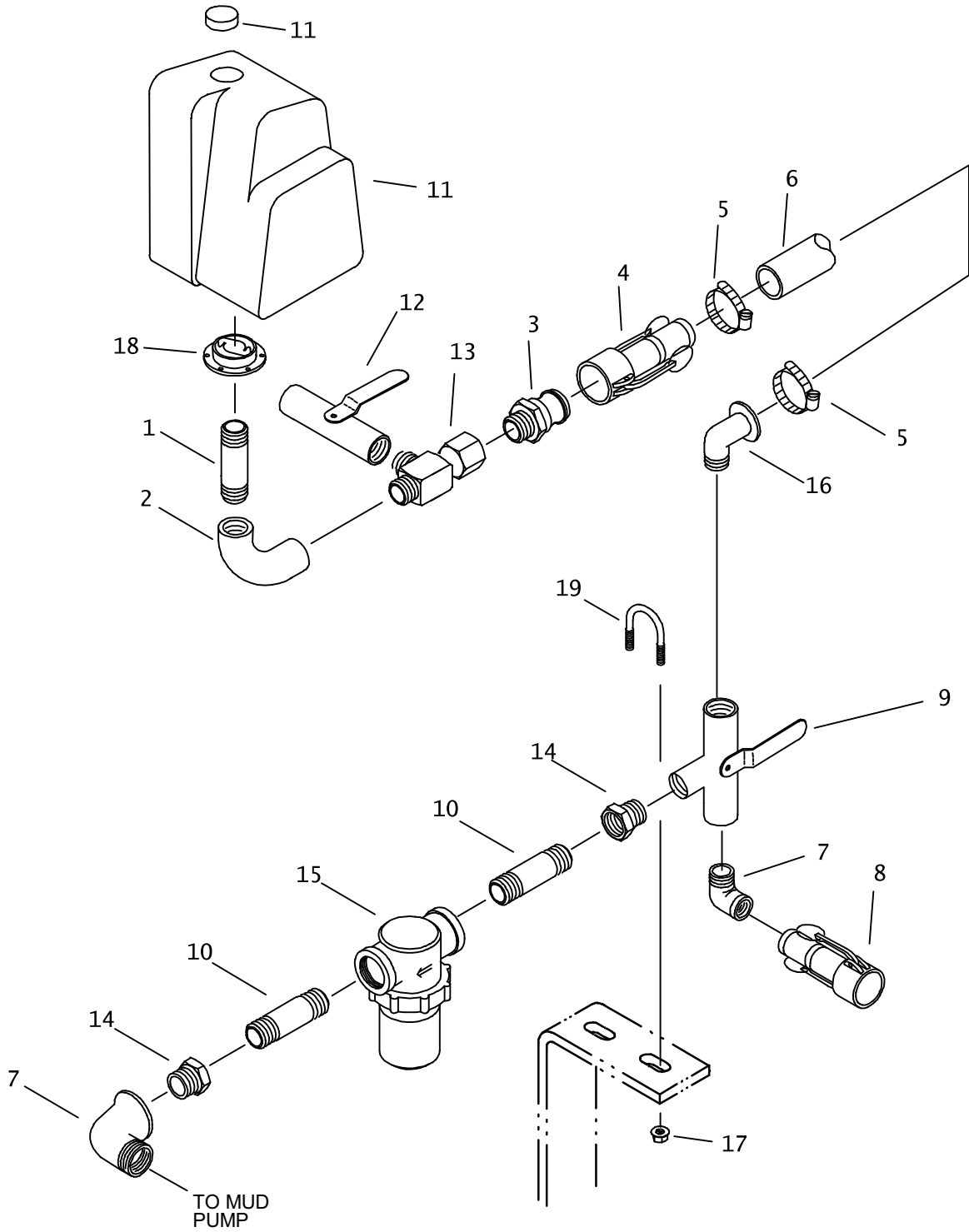

MUD TANK PLUMBING

REF NO.	PART NUMBER	QTY	DESCRIPTION	REMARKS
1.	115-206	1	NIPPLE (16N-2-1/2")	
2.	115-208	1	ELBOW (16NF-16NF90)	
3.	155-232	1	FHC ADAPTER (16-16N)	
4.	155-233	1	FHC BODY (16-16H)	
5.	110-353	2	WORM CLAMP (3/4" - 1-1/5")	
6.	116-460	AR	BULK HOSE (1", SOLD PER 1')	USE 1@ 42"
7.	115-440	2	STREET ELBOW (16N-16NF90)	
8.	149-137	1	FHC BODY (16FM-16N)	
9.	149-113	1	3-WAY SHUT-OFF (16NF) VALVE	STEEL
10.	115-163	2	ALL THREAD (12N) SCH 80	
	115-174	2	NIPPLE (12N-1.500" LG) SCH 40	
11.	364-276	-	WATER TANK	
	157-488		CAP/LID 5" (NEW THREAD)	BEGINS WITH S/N 2W0228
	157-490		BK CONNECTOR (16NF, POLY)	SEE FOOTNOTE 2
	157-189	-	O-RING (325 D70)	
	190-053	-	POLY PATCH TANK REPAIR KIT	
12.	158-579	1	SHUT-OFF (08NF-08NF)	
13.	514-024	1	BRANCH TEE (08N-16N-16NF)	
14.	115-151	2	REDUCER (16N-12NF)	
15.	153-133	1	STRAINER (12NF)	
	153-198	-	SCREEN (20-MESH)	
16.	155-137	1	S/O COUPLER (16N-16H90)	
17.	105-003	2	FLG LOCKNUT (5/16-NC)	
18.	157-490	1	BK CONNECTOR (16NF POLY)	
19.	107-563	1	U-BOLT (5/16-NC X 1 7/8")	

FOOTNOTES

1. REFER TO O-RING CHART (800-301) IN BACK OF THE BOOK FOR REPLACEMENT OF O-RINGS.
2. HOLES MAY REQUIRE MODIFICATION FOR NEW FITTINGS.

NOTE:

Q

805-085

FLUID PUMP PLUMBING

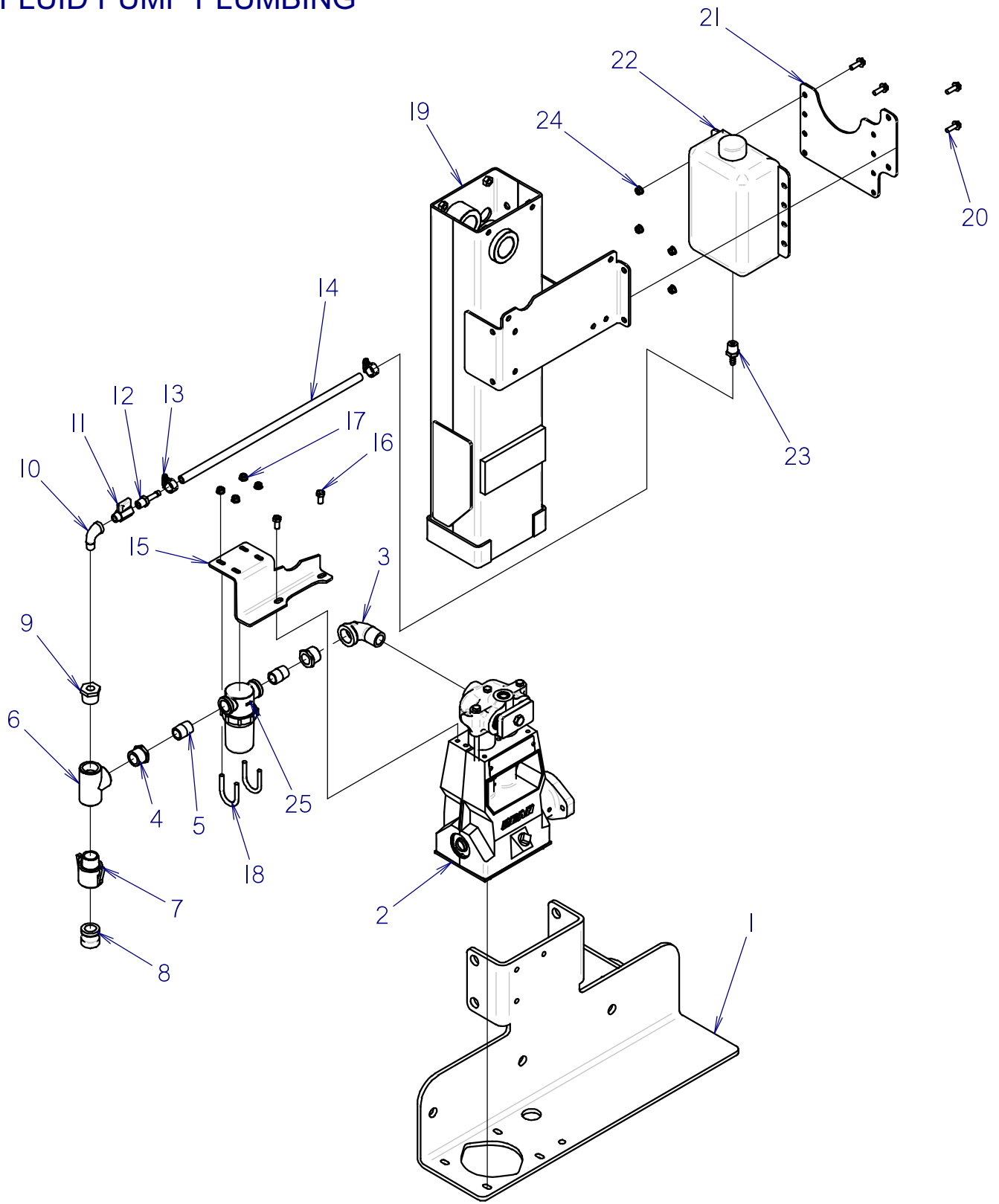

FLUID PUMP PLUMBING

REF NO.	PART NUMBER	QTY	DESCRIPTION	REMARKS
1	350-622	1	MUD WELDMENT	
2	158-465	1	MUD PUMP	
3	115-440	1	STREET ELBOW (16N-16NF90)	
4	115-151	2	REDUCER (16N-12NF)	
5	115-163	2	ALL THREAD (12N) SCH 80	
6	514-033	1	TEE (16NF)	
7	149-137	1	FHC CONNECTOR	
8	158-161	1	DUST PLUG (1-24 FHC)	
9	115-235	1	PIPE BUSHING (INPT TP 3/8NPT)	
10	115-217	1	STREET ELBOW (06N-06NF90)	
11	153-701	1	SHUTOFF (1-06N X -06NF)	
12	514-369	1	S/O COUPLER (06N-06H)	
13	110-217	2	WORM CLAMP (7/16" TO 1")	
14	116-881	1	BULK HOSE (3/8", SOLD PER FT)	USE 1 @ 20"
15	300-3724	1	STRAINER MOUNT	
16	105-032	2	BOLT (3/8-NC X 3/4")	
17	105-003	4	FLG LOCKNUT (5/16-NC)	
18	107-563	2	U-BOLT (5/16-NC X 1-3/8")	
19	353-289	1	UPPER STABILIZER TUBE	
20	106-992	4	FLG LK SCREW (M8-1.25 X 25MM)	
21	300-1577	1	TANK MOUNT BRACKET	
22	149-382	1	WATER TANK (1 GAL.)	
23	150-1901	1	FITTING (06H-08N)	
24	106-386	4	FLG LOCKNUT (M8-1.25)	
25	153-133	1	STRAINER	

NOT SHOWN:

FOOTNOTES:

STRAINER SUPPORT KIT I90-1186 INCLUDES REF #'s 15-18

JT921 ANTI-FREEZE KIT I90-1059 INCLUDES REF #'s 13, 14, 20-24

NOTE:

NOTES:

PIPE LOADER SYSTEMS

DRILL PIPE ACCESSORIES

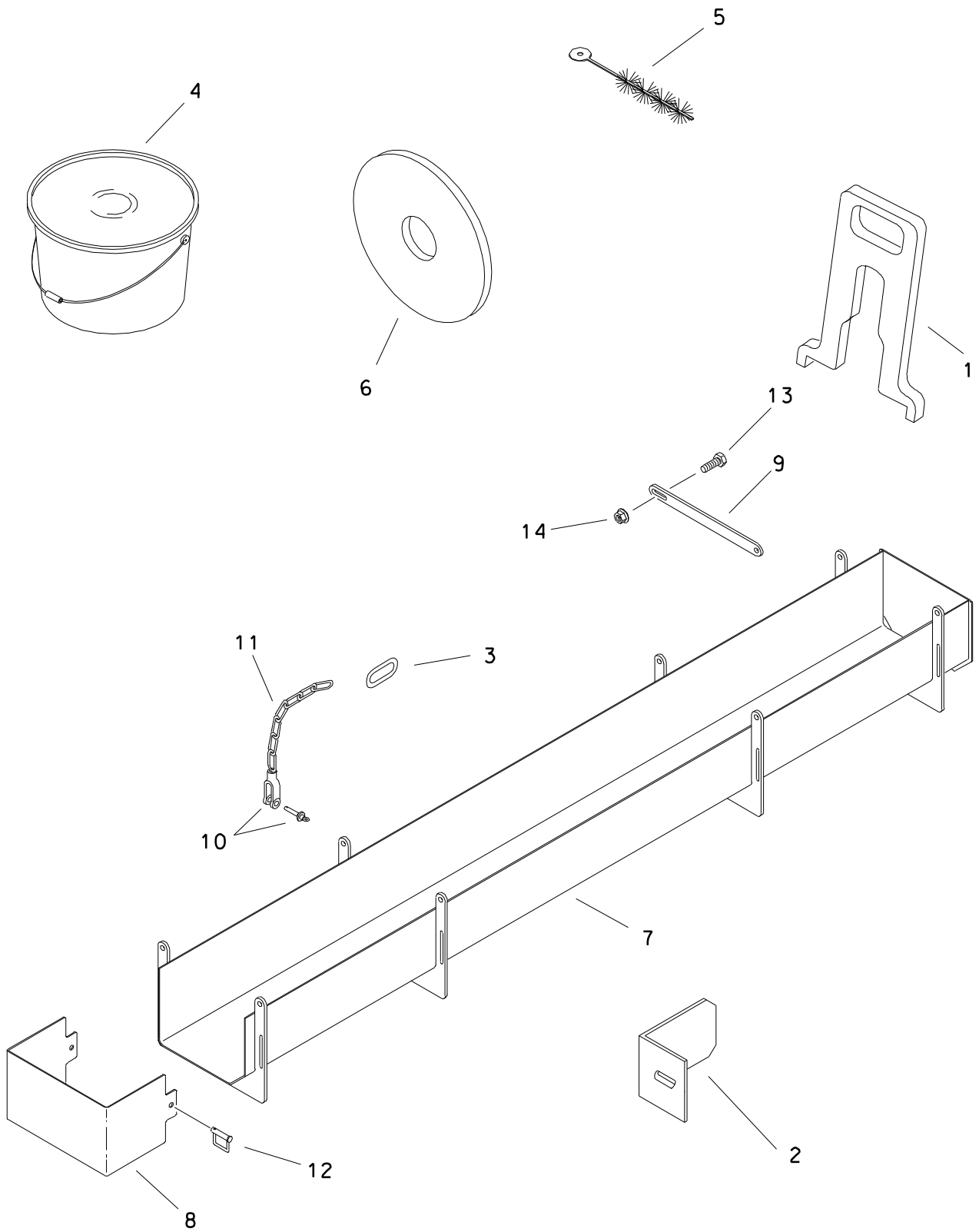

DRILL PIPE ACCESSORIES

REF NO.	PART NUMBER	QTY	DESCRIPTION	REMARKS
1.	258-007	1	WRENCH	
2.	356-288	4	ROD BOX SPACER	
3.	110-516	2	OBLONG LINK (1.5")	
4.	256-653	1	TOOL JOINT COMPND (2.5 GAL)	
	259-830	1	TOOL JNT LUBE (2 GAL)	
5.	259-199	1	COMPOUND BRUSH (#6)	
6.	116-515	1	ROD WIPER (1.00")	
	116-485	1	ROD WIPER (1.75")	
7.	356-289	1	DRILL PIPE BOX	
8.	358-683	1	END COVER	
9.	358-684	2	LOCK BAR	
10.	110-289	6	ANCHOR SHACKLE (5/16")	
11.	110-161	4	CHAIN (5/0 X 32.4")	
12.	110-368	4	SNAPPER PIN (3/8" X 1-1/2")	
13.	105-031	2	BOLT (3/8-NC X 1")	
14.	105-047	2	LOCKNUT (3/8-NC)	

FOOTNOTES

ACCESSORIES

FLUID MIXING ACCESSORIES

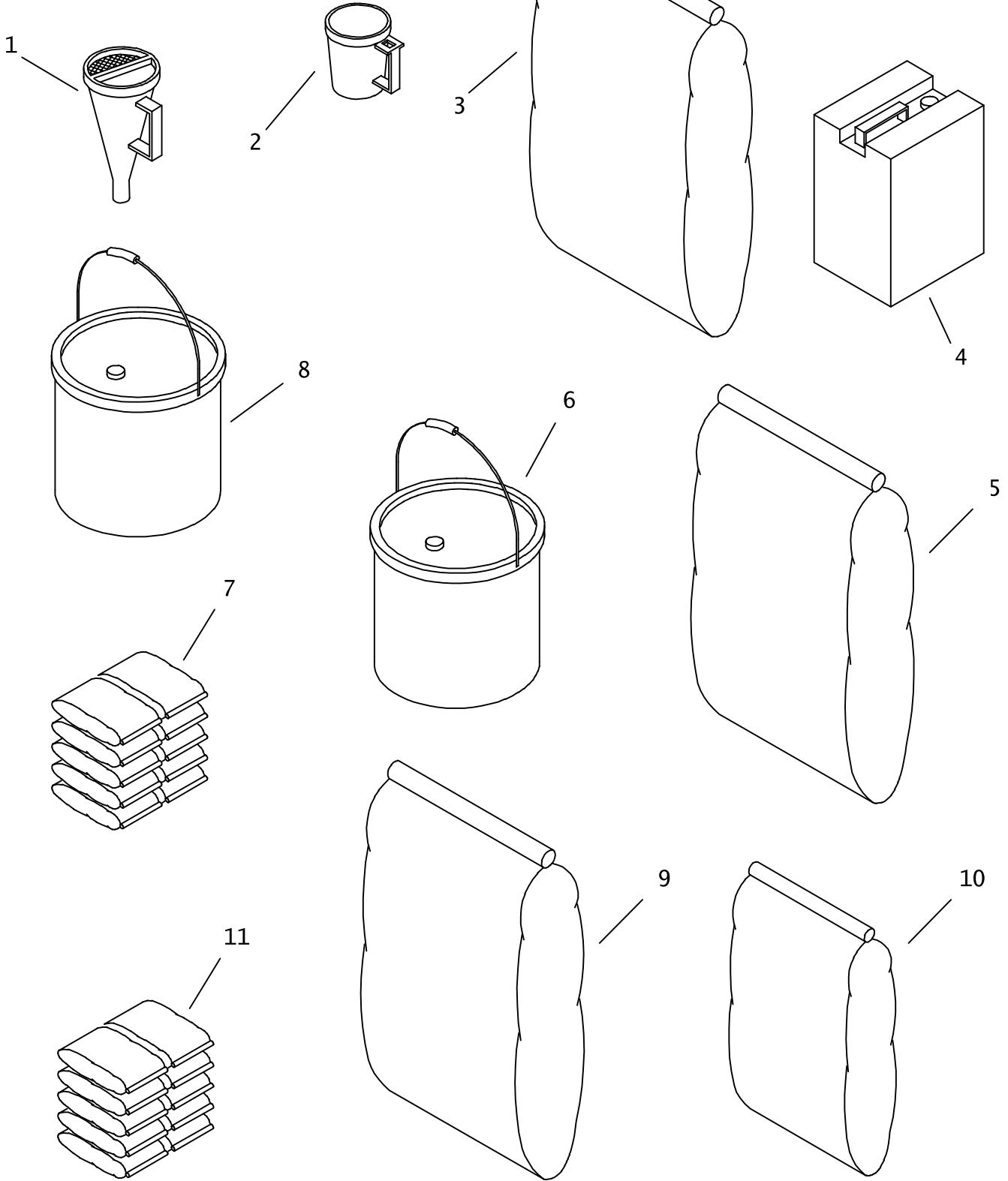

FLUID MIXING ACCESSORIES

REF NO.	PART NUMBER	QTY	DESCRIPTION	REMARKS
1.	259-195	1	VISCOSITY FUNNEL	
2.	259-196	1	VISCOSITY CUP	
3.	259-804	AR	BENTONITE, QUIK-GEL (50 LB)	
4.	259-805	AR	LIQUID POLYMER, EZ-MUD (5 GAL)	
5.	259-807	AR	BENTONITE, BORE-GEL (50 LB)	
6.	259-808	AR	VISCOSIFIER, LIQUI-TROL (5 GAL)	
7.	259-809	AR	POWDER POLYMER, QUIK-TROL (20 LB)	
8.	259-810	AR	WET AGENT, CON-DET (5 GAL)	
9.	259-821	AR	'PAC-R' FILTRATION CONTROL	
10.	259-822	AR	'BARAZAN D+' VISCOSIFIER	
11.	259-832	AR	'NO SAG' (20# BOX/10-2#BAGS)	

NOT SHOWN:

191-158	1	DRILLING FLUID TEST KIT
259-487	1	SHEAROMETER

FOOTNOTES:

NOTE:

GROUNDING CABLES

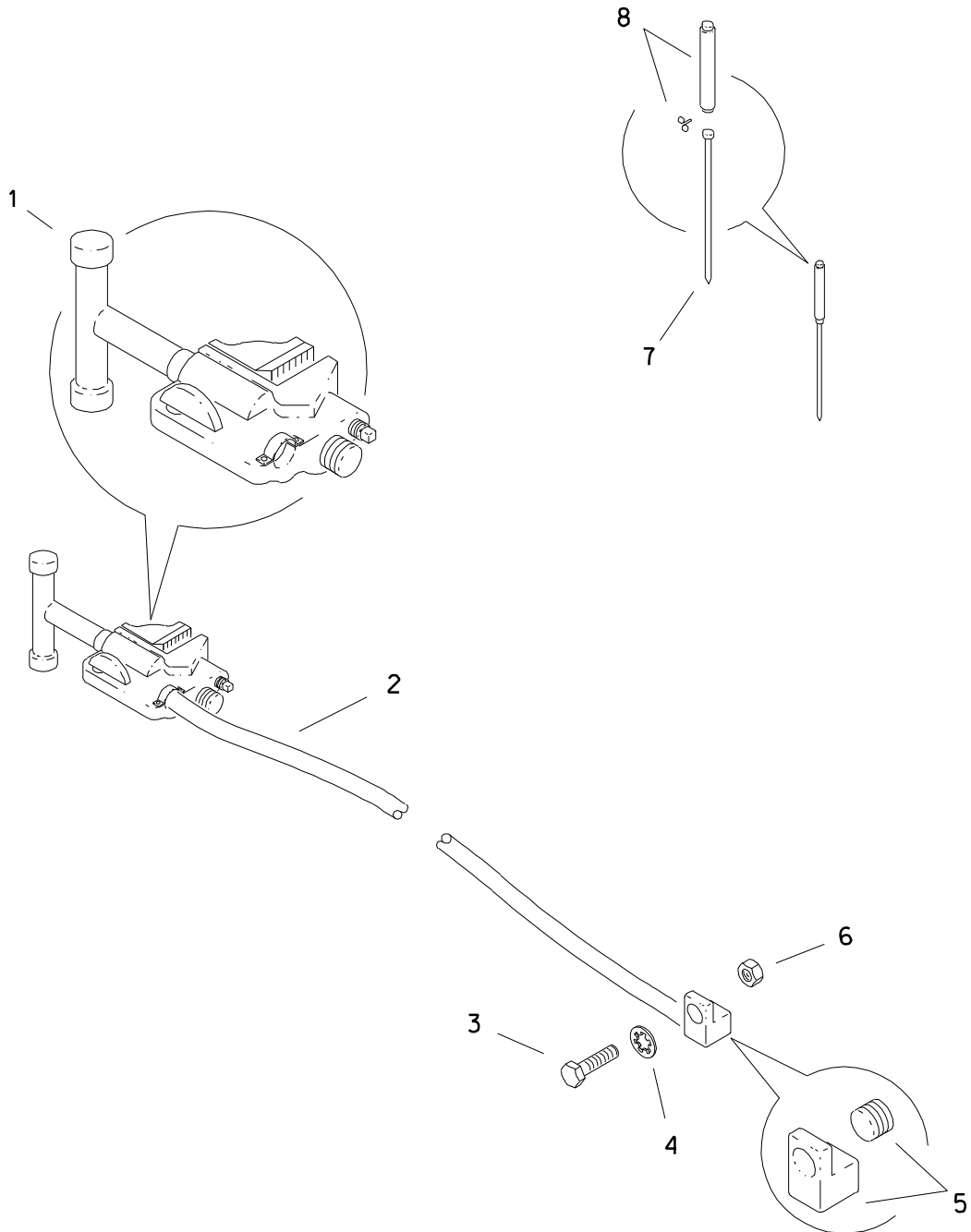

GROUNDING CABLES

REF NO.	PART NUMBER	QTY	DESCRIPTION	REMARKS
1	215-769	1	GROUND CLAMP	
2	215-813	1	GROUND CABLE (1/0 GA X 25')	INCL REF NO.'S 1 AND 5
	215-768	AR	GROUND CABLE (1/0 GA)	USE 25 FT
3	106-462	1	BOLT (3/8-NC X 1-1/4", SIL BRZ)	
4	106-220	1	INT STAR WASHER (3/8", SIL BRZ)	
5	215-773	1	RING LUG TERMINAL (27/64")	
6	106-454	1	LOCKNUT (3/8-NC, SIL BRZ)	
7	215-775	1	GROUND ROD	
8	215-776	1	SLIDE DRIVER	

FOOTNOTES

WATER TRANSFER SYSTEM

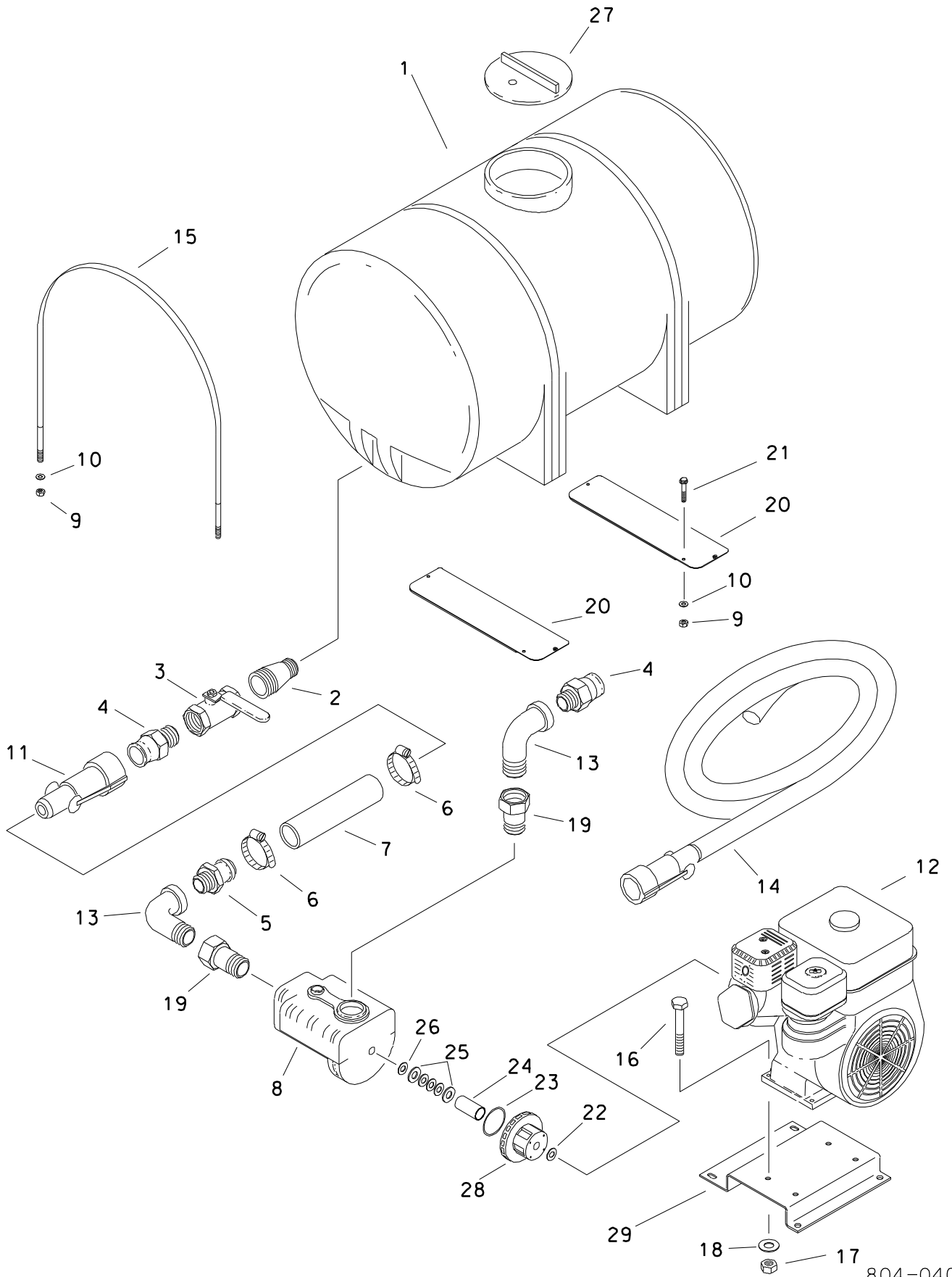

WATER TRANSFER SYSTEM

REF NO.	PART NUMBER	QTY	DESCRIPTION	REMARKS
	<u>100-956</u>		WATER TRANSFER SYSTEM	
1.	364-314	1	STORAGE TANK (325 GAL)	
	190-053		POLY-PATCH TANK REPAIR KIT	
2.	115-437	1	SWEDGE NIPPLE (32N-24N-6.5")	
3.	120-023	1	SHUT-OFF (24NF-24NF)	
4.	155-204	2	FHC ADAPTER (20-24N)	
5.	155-188	1	SLIP-ON COUPLER (24N-24H)	
6.	110-250	2	WORM CLAMP (1-1/4" TO 2-1/8")	
7.	116-782	AR	BULK HOSE (1-1/2", SOLD PER 1")	USE 1 @ 18"
8.	149-929	1	CENTRIFUGAL PUMP	INCL REF NO.'S 22 - 26
9.	105-065	4	LOCKNUT (1/2-NC)	
10.	105-071	4	WASHER (1/2")	
11.	155-205	1	FHC BODY (20-24H)	
	116-491		SQUARE RING (___ D70)	
12.	195-028	1	ENGINE-HONDA	
13.	115-044	2	STREET ELBOW (24N-24NF90)	
14.	154-440	1	HOSE (20FHC-300"-44)	
15.	365-374	2	TANK STRAP	
16.	105-130	4	BOLT (5/16-NC X 2-1/4")	
17.	105-089	4	LOCKNUT (5/16-NC)	
18.	105-117	4	WASHER (5/16")	
19.	115-087	2	REDUCER (32N-24NF)	
20.	<u>344-901</u>	2	BASE PLATE	
21.	105-067	2	BOLT (1/2-NC X 2-3/4")	
22.	500-860	1	SLINGER	
23.	500-248	1	O-RING (246 D70)	
24.	180-817	1	SLEEVE	
25.	191-017	1	PUMP SEAL KIT	
26.	165-834	1	SHIM (.015", IMPELLER)	
27.	364-434	1	TANK CAP (16", VENTED)	
28.	194-044	1	ENGINE ADAPTER	FOR HONDA & LOMBARDINI 5.5 HP ENGINES
29.	346-350	-	ENGINE MOUNT PLATE	NOT INCLUDED WITH SYSTEM

FOOTNOTES

WASH WAND

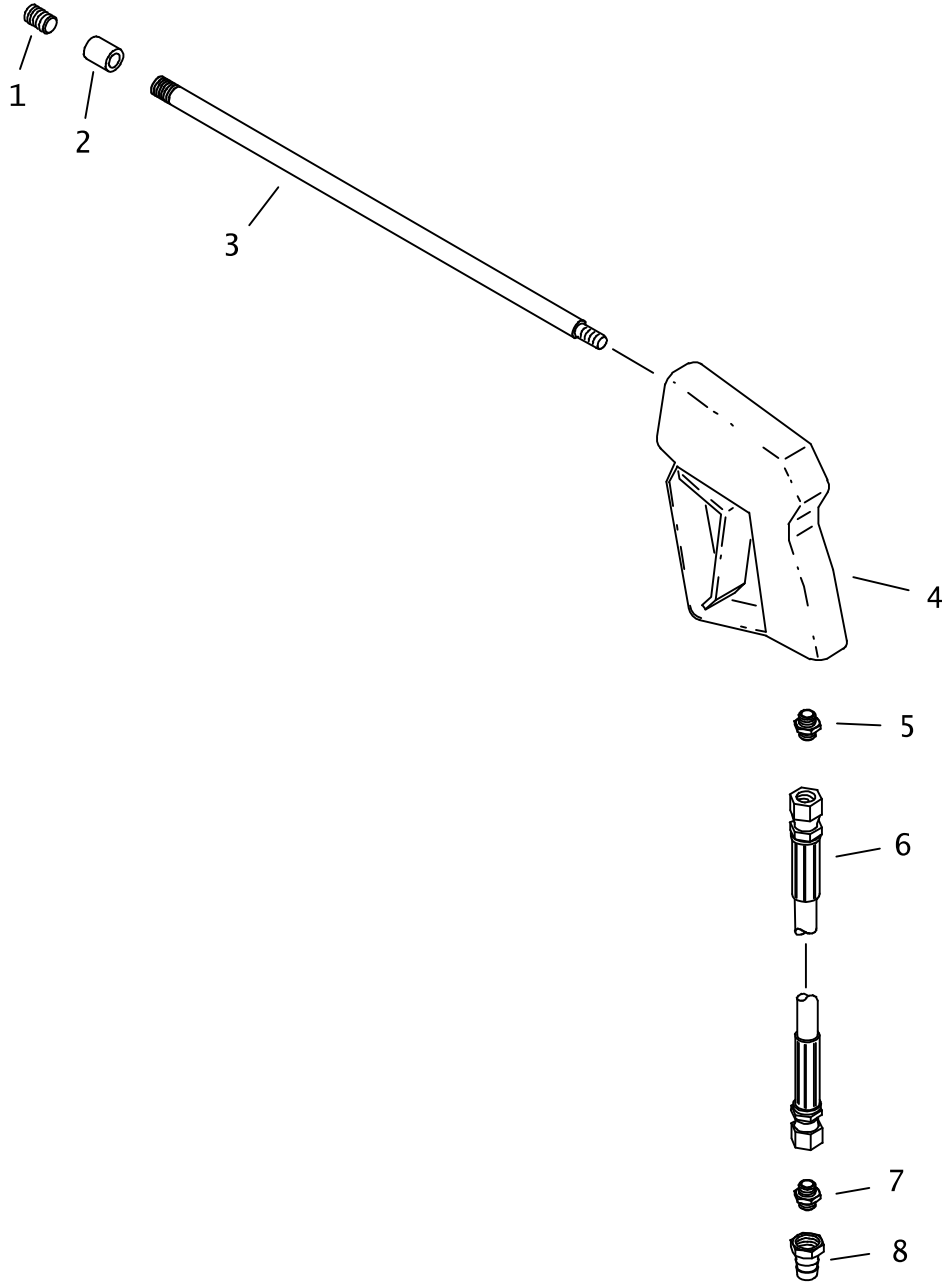

WASH WAND

REF NO.	PART NUMBER	QTY	DESCRIPTION	REMARKS
	259-374		WATER SPRAY GUN (PARTS ASS'Y)	INCL REF NO.'S 1 THRU 8
1.	155-242	1	NOZZLE (04N, ORF. 047", TC)	
2.	115-170	1	COLLAR (04NF)	
3.	259-353	1	WASH WAND (04N-36")	
4.	259-197	1	SPRAY GUN	
	190-179	1	SEAL REPAIR KIT	
5.	514-141	1	CONNECTOR (06N-080)	
6.	154-804	1	HOSE (080FX-290"-3000)	
7.	154-233	1	CONNECTOR (08S-080)	
8.	159-089	1	QDC ADAPTER (08-08SF)	
	190-186	1	SEAL REPAIR KIT	

NOT SHOWN:

FOOTNOTES:

NOTE:

REFER TO O-RING CHART (800-301) IN BACK OF THE BOOK FOR REPLACEMENT OF O-RINGS.

GARDEN HOSE ADAPTER

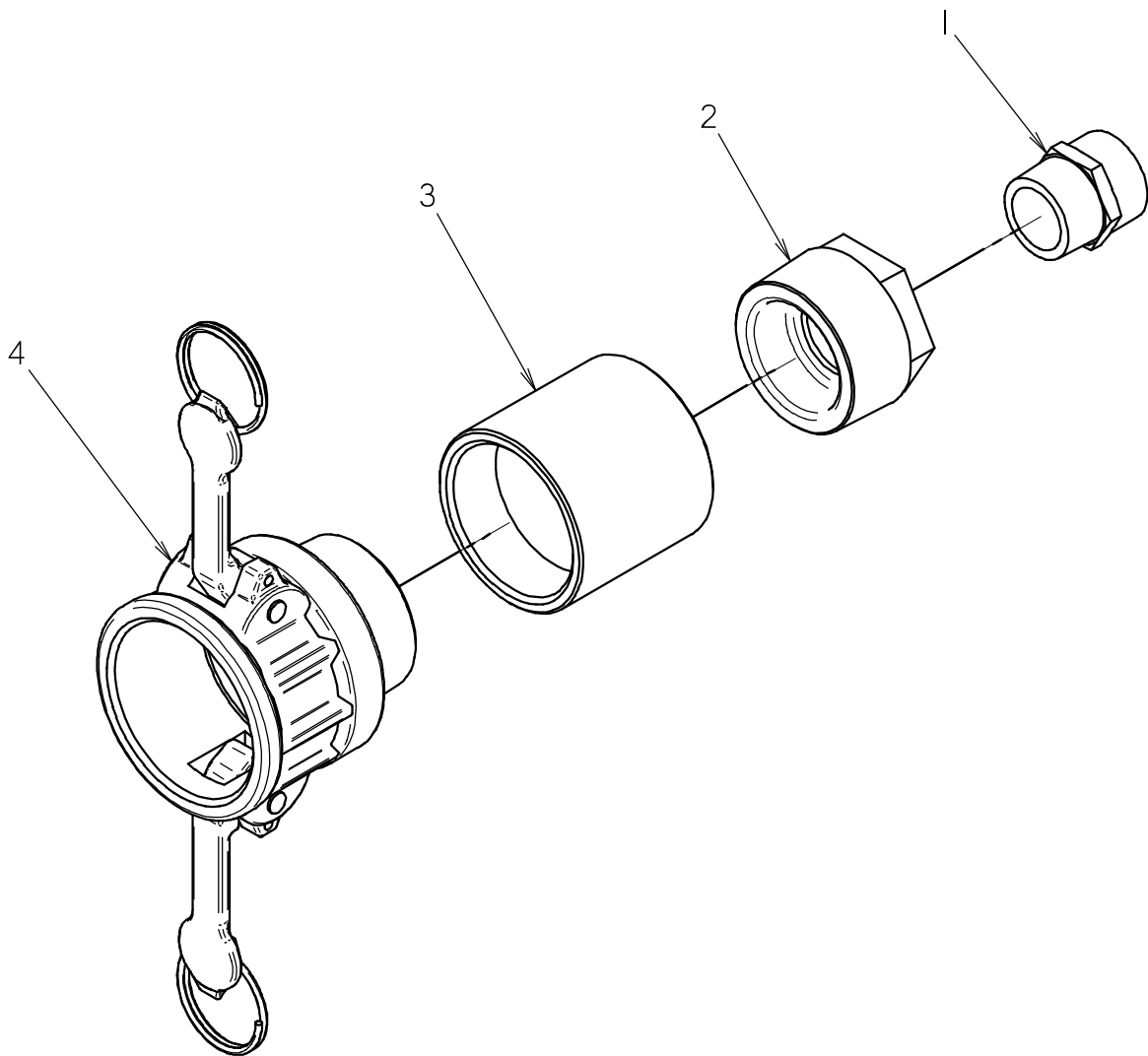

GARDEN HOSE ADAPTER

REF NO.	PART NUMBER	QTY	DESCRIPTION	REMARKS
	159-891		GARDEN HOSE ADAPTER	INCL. REF No's 1 - 4
1	114-038	1	NIPPLE (12N-12NH)	
2	115-271	1	REDUCER (24N-12NF)	
3	115-134	1	COLLAR (24NF)	
4	159-500	1	FHC BODY (24-24N)	

NOT SHOWN:

FOOTNOTES:

NOTE:

DRILLING FLUID TRANSFER

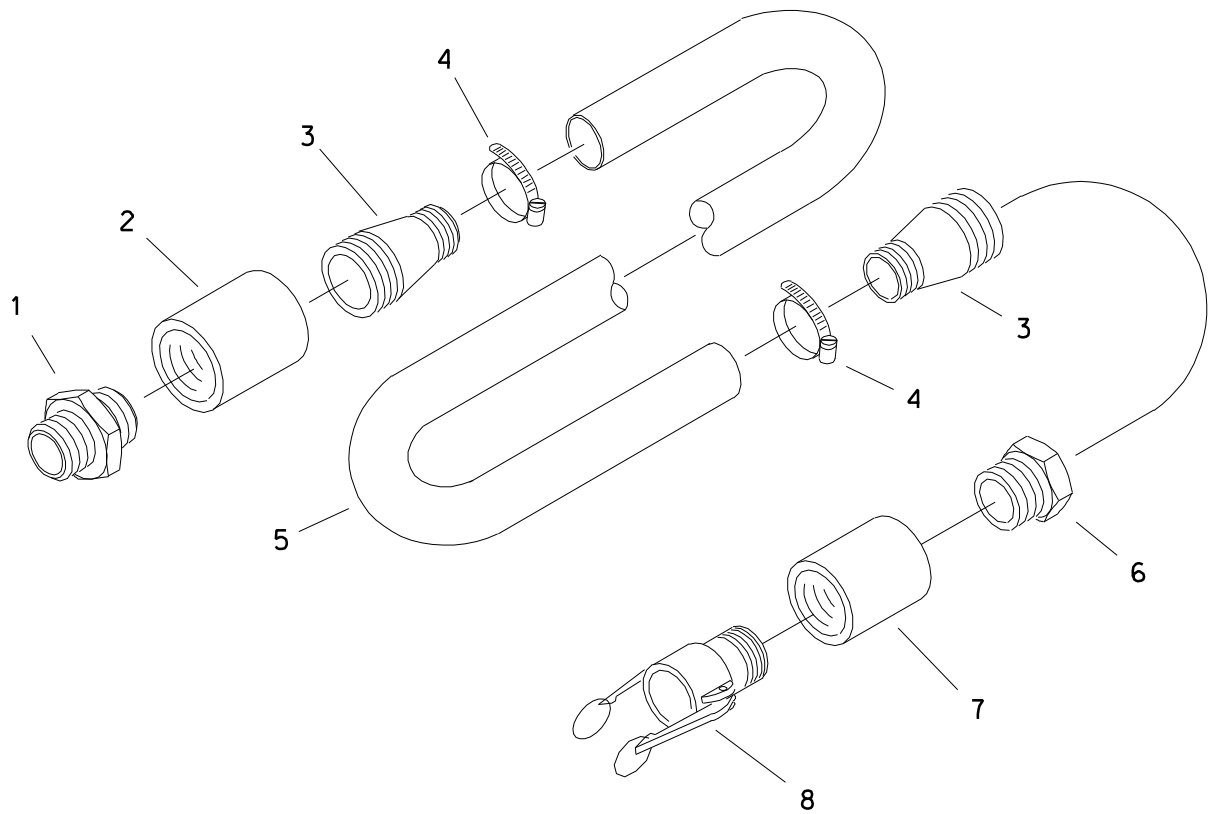

DRILLING FLUID TRANSFER

REF NO.	PART NUMBER	QTY	DESCRIPTION	REMARKS
	159-890	-	TRANSFER HOSE ASSEMBLY	
1.	155-232	1	FHC ADAPTER (16-16N)	
2.	115-175	1	COLLAR (16NF)	
3.	514-311	2	S/O COUPLER (16N-16H)	
4.	110-353	2	WORM CLAMP (3/4" TO 1-1/2")	
5.	117-451	-	1" SUCTION HOSE (SOLD PER FT)	1 @ 50'
6.	514-314	1	REDUCER (24N-16NF)	
7.	115-134	1	COLLAR (24NF)	
8.	159-500	1	FHC BODY (24-24N)	

FOOTNOTES

NOTES:

MISCELLANEOUS

SAE Bolt and Nut Torque Value Chart

Grade 5: UNC or UNF Thread

Size	Hex nut, or bolt tapped into hex nut, or d&t hole		Hex top deformed locknut		Flange nut, locknut, or bolt tapped into flange nut or d&t* hole	
	ft•lb	N•m	ft•lb	N•m	ft•lb	N•m
1/4	12	16	8	11	20	27
5/16	25	34	15	20	45	60
3/8	40	54	25	34	75	100
7/16	65	90	40	55	125	170
1/2	100	135	60	80	190	260
9/16	150	200	90	125	270	370
5/8	200	270	120	165	370	500
3/4	350	475	210	285	650	880
7/8	560	760	340	460	1250	1425
1	840	1140	500	680	1580	2145
1-1/8	1030	1400	320	840	1950	3645
1-1/4	1460	1980	880	1195	2760	3475

Grade 8: UNC or UNF Thread

Size	Hex nut, or bolt tapped into hex nut, or d&t hole		Hex top deformed locknut		Flange nut, locknut, or bolt tapped into flange nut or d&t* hole	
	ft•lb	N•m	ft•lb	N•m	ft•lb	N•m
1/4	14	19	10	14	24	33
5/16	30	40	18	25	50	70
3/8	55	73	35	50	90	125
7/16	85	115	50	70	140	190
1/2	130	175	80	110	220	300
9/16	190	260	110	150	310	420
5/8	260	355	160	245	430	585
3/4	450	610	270	365	750	1015
7/8	730	990	440	600	1210	1640
1	1090	1480	650	880	1320	2465
1-1/8	1550	2100	930	1260	2580	3500
1-1/4	2180	2955	1310	1780	3640	4935

*drilled and tapped

Metric Bolt and Cap Screw Torque Values

Size	Class 4.8				Class 8.8 and 9.8				Class 10.9				Class 12.9			
	Lubricated		Dry		Lubricated		Dry		Lubricated		Dry		Lubricated		Dry	
	N•m	ft•lb	N•m	ft•lb	N•m	ft•lb	N•m	ft•lb	N•m	ft•lb	N•m	ft•lb	N•m	ft•lb	N•m	ft•lb
M6	4.8	3.5	6	4.5	9	6.5	11	8.5	13	9.5	17	12	15	11.5	19	14.5
M8	12	8.5	15	11	22	16	28	20	32	24	40	30	37	28	47	35
M10	23	17	29	21	43	32	55	40	63	47	80	60	75	55	95	70
M12	40	29	50	37	75	55	95	70	110	80	140	105	130	95	165	120
M14	63	47	80	60	120	88	150	110	175	130	225	165	205	150	260	190
M16	100	73	125	92	190	140	240	175	275	200	350	225	320	240	400	300
M18	135	100	175	125	260	195	330	250	375	275	475	350	440	325	560	410
M20	190	140	240	180	375	275	475	350	530	400	675	500	625	460	800	580
M22	260	190	330	250	510	375	650	475	725	540	925	675	850	625	1075	800
M24	330	250	425	310	650	475	825	600	925	675	1150	850	1075	800	1350	1000
M27	490	360	625	450	950	700	1200	875	1350	1000	1700	1250	1600	1150	2000	1500
M30	675	490	850	625	1600	950	1650	1200	1850	1350	2300	1700	2150	1600	2700	2000
M33	900	675	1150	850	1750	1300	2200	1650	2500	1850	3150	2350	2900	2150	3700	2750
M36	1150	850	1450	1075	2250	1650	2850	2100	3200	2350	4050	3000	3750	2750	4750	3500

Do not use these values if a different torque value or tightening procedure is given for specific application. Torque values listed are for general use only. Check tightness of fasteners periodically.

Shear bolts are designed to fail under predetermined loads. Always replace shear bolts with identical property class fasteners.

Fasteners should be replaced with the same or higher property class. If higher property class fasteners are used, these should only be tightened to strength of original.

Make sure fastener threads are clean and that the threads are properly started. This will prevent them from cross threading or galling when tightened.

Tighten plastic insert or crimped type steel locknuts to approximately 50% of dry torque indicated on chart. Apply torque to the nut - not the bolt head. Tighten toothed or serrated type locknuts to full torque value.

LUBRICATED means coated with lubricant. DRY means plain or zinc plated without any type of lubricant.

Hydraulic Cylinder Bolt Torque Chart

Bolt Size (inch)	Bolt Part No.	Cylinder Repair Kit Part No.	Torque (ft•lb)	Torque (N•m)
1/2	106-096	190-165	90-100	120-135
5/8	106-097	190-166 & 190-169	180-200	245-270
3/4	106-098	190-167 & 190-170	290-325	395-440
7/8	106-122	190-172 & 190-174	410-640	550-625
1	106-145	190-175 & 190-189	630-700	855-950
1-1/8	106-146	190-177	770-850	1045-1170

As a general rule:

- 1/2-inch bolts are used in cylinders with 1-inch rods
- 5/8-inch bolts are used in cylinders with 1 1/4-inch rods
- 3/4-inch bolts are used in cylinders with 1 1/2-inch rods
- 7/8-inch bolts are used in cylinders with 1 3/4-inch rods
- 1-inch bolts are used in cylinders with 2-inch rods (one with 1 3/4-inch)
- 1-1/8-inch bolts are used in cylinders with 2-1/4-inch rods

IMPORTANT: Do not reuse cylinder piston bolts when rebuilding a hydraulic cylinder. Each cylinder repair kit contains a new bolt. Use it. Lubricate lightly and torque to value shown on chart.

SAE & ORS Hydraulic Fitting Replacement O-Ring Chart

Fraction Size	Dash Size	SAE (Port Seal O-Ring)		ORS (Face Seal O-Ring)	
		Thread Size	O-Ring P/N	Thread Size	O-Ring P/N
1/16	1	NA	NA	NA	NA
1/8	2	5/16 - 24	NA	NA	NA
3/16	3	3/8 - 24	NA	NA	NA
1/4	4	7/16 - 20	155-760	9/16 - 18	157-037
5/16	5	1/2 - 20	NA	NA	NA
3/8	6	9/16 - 18	155-705	11/16 - 16	157-038
1/2	8	3/4 - 16	155-706	13/16 - 16	157-039
5/8	10	7/8 - 14	155-707	1 - 14	157-040
3/4	12	1-1/16 - 12	155-709	1-3/16 - 12	157-017
7/8	14	1-3/16 - 12	155-747	NA	NA
1	16	1-5/16 - 12	155-748	1-7/16 - 12	155-714
1-1/4	20	1-5/8 - 12	155-702	1-11/16 - 12	NA
1-1/2	24	1-7/8 - 12	157-001	2 - 12	NA
2	32	2-1/2 - 12	NA	NA	NA
2-1/2	40	3 - 12	NA	NA	NA
3	48	3-1/2 - 12	NA	NA	NA

Thread size indicates the diameter of the threaded area in fractions of an inch and number of threads per inch.

NA = not a current CMW part numbered o-ring, or dash size does not occur in current CMW applications

SAE = straight thread fitting that seals by sandwiching a hard o-ring between a shoulder on the male part and an angular surface at the mouth of the female port.

ORS = o-ring face seal; a type of fitting that seals by compressing a hard, captive o-ring between two flat parallel faces, one grooved for the o-ring and the other plain to act as the sealing surface

JT921

Related Publications

Component	Ass'y	P/N
Model:		
JT921	Parts Manual	053-151
JT921	Operators Manual	054-135
JT921	Repair Guide (Service Manual)	055-498
Engine:		
Caterpillar 3024C or Perkins 404C-22	Parts Manual	053-144
Caterpillar 3024C or Perkins 404C-22	Mnt. Manual	054-128
Caterpillar 3024C or Perkins 404C-22	Service Manual	055-076
Caterpillar/Perkins.....	User Handbook	056-005
WATER TRANSFER SYSTEM OPTION:		
Honda 5.5hp	Parts Manual - GX160K1TX	195-028 ... 053-042
Honda 5.5hp	Operators Manual - GX160K1TX	N/A
Honda 5.5hp	Service (Shop) Manual - GX160K1TX	N/A

Filters

Engine:

Caterpillar 3024C or Perkins 404C-22

Air Filter Parts Ass'y	194-297
Element (Safety)	194-758
Element (Primary)	194-759
Oil Filter Element	153-113
Fuel Filter Element (30 Micron)	194-491
Fuel Filter Element (2 Micron)	194-551

WATER TRANSFER SYSTEM OPTION:

Air Filter Parts Ass'y - Honda 5.5hp (GX160K1TX)	N/A
Element Set (primary, paper) - Honda (GX160K1TX)	194-001
(secondary, foam) - Honda (GX160K1TX)	194-001
Fuel Filter (04H-04H, in-line) - Honda 5.5hp (GX160K1TX)	194-002

Hydraulic:

Oil Filter Element (1-1/2-UNF, spin-on, Replacement)	159-079
Element (1-1/2-UNF, spin-on, Break-In)	149-840
Oil Strainer (24S-20SF)	110-336

Optional Kits

JT921

O-ring Repair Kit - FLG, ORS & SAE (15 different O-rings)	190-051
O-ring Repair Kit - Field Service (46 different O-rings)	190-052



Parts Manual Change Request

(Please print clearly)

Date: _____ Dealer No. (required): _____

Your Name: _____ Position: _____

Phone: _____ Fax: _____ E-mail: _____

Publication Information:

Parts Manual No.: _____ - _____ Model: _____

Illustration Part No.:	Manual Page No.:
1. _____ - _____	1. _____
2. _____ - _____	2. _____
3. _____ - _____	3. _____

Nature of Change Request:

- Text
 Graphics
 Missing Information

Describe change requested (if possible, include copy of publication page with changes marked.):

Please fax completed form to
Parts Manual Department (580) 572-3525

Thank you for taking the time to submit this request. We will contact you if further information is needed to process your request.

**A Note To
Ditch Witch
Equipment Owners:**

If your equipment was purchased through a Ditch Witch dealer, there is no need to read further.

However, if you purchased from any other source, please fill out the form on the reverse side and return it to us.

This will enable you to receive updates on this equipment as well as information on new products of interest.

Thanks for using Ditch Witch equipment.

(Please Fold Along This Line And Seal At Bottom With Tape)



**NO POSTAGE
NECESSARY
IF MAILED
IN THE
UNITED STATES**

BUSINESS REPLY MAIL
FIRST CLASS PERMIT NO 23 PERRY OKLAHOMA

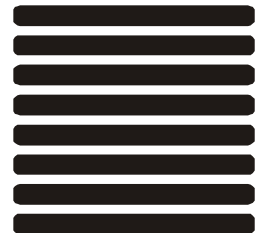

POSTAGE WILL BE PAID BY

**The Charles Machine Works, Inc.
P.O. Box 66
Perry, Oklahoma 73077-9989**



Ditch Witch® Registration Card

Please Type or Print All Information

Purchaser's Company Name

Attention

Street Address or P.O. Box

City County

State Zip Nation

()

Phone Number With Area Code

Model S rial Number

Attachments/Accessories Serial Numbers

Attachments/Accessories Serial Numbers

Attachments/Accessories Serial Numbers

Name of Ditch Witch Dealership

Your Signature